

## Chapter 7

# Creators and Creations in Mechanical Engineering

Fest gemauert in der Erden  
Steht die Form, aus Lehm gebrannt.  
Heute muß die Glocke werden.  
Frisch Gesellen, seid zur Hand.  
Von der Stirne heiß  
Rinnen muß der Schweiß,  
Soll das Werk den Meister loben,  
Doch der Segen kommt von oben.

Zum Werke, das wir ernst bereiten,  
Geziemt sich wohl ein ernstes Wort;  
Wenn gute Reden sie begleiten,  
Dann fließt die Arbeit munter fort.  
So laßt uns jetzt mit Fleiß betrachten,  
Was durch die schwache Kraft entspringt,  
Den schlechten Mann muß man verachten,  
Der nie bedacht, was er vollbringt.  
Das ist's ja, was den Menschen zieret,  
Und dazu ward ihm der Verstand,  
Daß er im innern Herzen spüret,  
Was er erschafft mit seiner Hand.

Nehmet Holz vom Fichtenstamme,  
Doch recht trocken laßt es sein,  
Daß die eingepreßte Flamme  
Schlage zu dem Schwalch hinein.  
Kocht des Kupfers Brei,  
Schnell das Zinn herbei,  
Daß die zähe Glockenspeise  
Fließe nach der rechten Weise.

Walled up in the earth so steady  
Burned from clay, the mould doth stand.  
This day must the Bell be ready!  
Fresh, O workmen, be at hand!  
From the heated brow  
Sweat must freely flow,  
That the work may praise the Master,  
Though the blessing comes from higher.

Our work in earnest preparation,  
Befitteth well an earnest word;  
When joined by goodly conversation,  
Then flows the labor briskly forw'd.  
So let us now with care consider,  
What through a frail power springs forth:  
The wicked man one must have scorn for,  
Who ne'er reflects, what he brings forth.  
This it is, what all mankind graceth,  
And thereto his to understand,  
That he in inner heart so traceth,  
What he createth with his hand.

Take the wood from trunk of spruce tree,  
Yet quite dry let it abide,  
That the flame compressed so tightly  
Strike the gullet deep inside!  
Cook the copper brew,  
Quick the tin in, too!  
That the glutinous bell-metal  
Flowing rightly then will settle!

Was in des Dammes tiefer Grube  
 Die Hand mit Feuers Hülfe baut,  
 Hoch auf des Turmes Glockenstube  
 Da wird es von uns zeugen laut.  
 Noch dauern wird's in späten Tagen  
 Und rühren vieler Menschen Ohr  
 Und wird mit dem Betrübten klagen  
 Und stimmen zu der Andacht Chor.  
 Was unten tief dem Erdensohne  
 Das wechselnde Verhängnis bringt,  
 Das schlägt an die metallne Krone,  
 Die es erbaulich weiterklingt.

What in the dam's dark cavern dour  
 The hand with fire's help did mould,  
 High in the belfry of the tower  
 There will our story loud be told.  
 Still will it last as years are tolling  
 And many ears will it inspire  
 And wail with mourners in consoling  
 And harmonize devotion's choir.  
 What here below to son terrestr'al  
 The ever-changing fate doth bring,  
 Doth strike the crown which made from metal,  
 Uplifting it doth sound its ring.

Friedrich Schiller. 1798. Das Lied von der Glocke [The Song of the Bell].  
 English verse translation by Marianna Wertz.

This chapter gives an overview of some innovations in mechanical engineering that have played major roles in the modern world and that were invented or discovered by scientists and engineers who were trained in the predominantly German-speaking central European research world in the nineteenth and early twentieth centuries.<sup>1</sup>

---

<sup>1</sup>In addition to specific references that are cited in different areas throughout this chapter, this chapter makes use of general biographical and project information from: ACLS 2000; Albrecht et al. 1992; Ash and Söllner 1996; Bar-Zohar 1967; Bower 1987; Bunch and Hellemans 2004; Challoner 2009; Cornwell 2003; Crim 2018; EB 1911, 2010; Gillispie 1970–1990; Gimbel 1990a; Glatt 1994; Hall 2019a; István Hargittai 2006, 2011; Linda Hunt 1991; Impey et al. 2008; Jacobsen 2014; Koertge 2007; Kurowski 1982; Lasby 1971; Luser 1956, 1971; Medawar and Pyke 2000; Mick 2000; Murray 2003; Nachmansohn 1979; NDB 1953–2020; Neufeld 2012; Nouzille and Huwart 1999; O'Reagan 2014, 2019; Porter 1994; Charles Walker 1946; Peter Watson 2010; Weitensfelder 2009.

For general overviews of large portions of the history of mechanical engineering in the German-speaking world, see: Buchheim and Sonnemann 1990; Bunch and Hellemans 2004; Cardwell 1995; Challoner 2009; Gööck 2000; Heckl 2010, 2011; Heßler 2012; Jankowsky 2000; König 2000, 2009; König and Schneider 2007; Ludwig 1974; Lundgreen and Grelon 1994; Radkau 1989, 2016; Technisches Museum Wien 2011; Weitensfelder 2009, 2013.

**I have deliberately left a blank space where images of some creators or creations should go.** Those are people or projects that I felt were important enough that they should definitely be shown in this book, yet I have not yet been able to locate a suitable image that I have permission to use, despite my searches in Europe and in the United States. If readers have any relevant images and could send them to me, I would be very grateful and will include them in future editions of this book. Even where a suitable photo cannot be located, I believe that leaving a blank space pays tribute both to the scientific importance of that creator or creation and to how that historical fact has been very nearly forgotten.



Creators from the German-speaking world made major contributions to:

- 7.1. Writing and printing technology
- 7.2. Musical instruments
- 7.3. Internal combustion engines and motor vehicles
- 7.4. Heat transfer
- 7.5. Civil engineering and architecture
- 7.6. Projectile weapons
- 7.7. Ocean engineering
- 7.8. Other aspects of mechanical engineering

Scientists and engineers from the German-speaking world also made numerous contributions to overlapping and related areas of engineering listed in Chapters 6 (electrical and electromagnetic engineering), 8 (nuclear engineering), and 9 (aerospace engineering).

## 7.1 Writing and Printing

German-speaking creators made many of the major innovations in technologies for writing and printing, including:<sup>2</sup>

- 7.1.1. The printing press
- 7.1.2. Typewriters
- 7.1.3. Stationery supplies
- 7.1.4. Improved printing processes

---

<sup>2</sup>For coverage of different aspects of this area, see especially: Ebeling 1985; Eisenstein 2005; Febvre and Martin 2010; Füssel 2004; Halkasch 1993; Hellbeck 2008; Kapr 1996; Kasischke 1999; Lassnig 1993; Lessing 2003, 2010; Michael Rauck 1983; Max Rößler 1982; Schlesinger 1989; Schmidt-Bachem 2011; Technisches Museum Wien 2005; Waize 2003; Wolf 1974.

### 7.1.1 Printing Press

Although this event preceded the time period that is the primary focus of this book, it would be impossible not to mention that Johannes Gutenberg (Mainz, ca. 1400–1468) invented the printing press around 1436 [Eisenstein 2005; Febvre and Martin 2010; Füssel 2004; Kapr 1996]. See Fig. 7.1. Donald Cardwell, a professor of the history of technology, described the enormous significance of Gutenberg’s innovations [Cardwell 1995, p. 55]:

Gutenberg’s printing press revolutionized the publication of books. The first known printed book, produced at Mainz in 1455, was the Gutenberg Bible. It has been estimated that more books were published in the first fifty years following Gutenberg (up, that is, to the beginning of the sixteenth century) than had been produced in the previous thousand years. A twentyfold increase in productivity is highly impressive and it would not be unreasonable to regard Gutenberg as the first production engineer. Furthermore, it is easy to overlook Gutenberg’s achievement of complete interchangeability in manufacture; each little unit of type could be used over and over again and fitted between any other little units[...] Finally, his invention brought about the first revolution in information technology. It was to be a long time—two hundred and fifty years—before another invention as dramatic and as important as Gutenberg’s was to be made.

### 7.1.2 Typewriters

As shown in Fig. 7.2, Karl von Drais (German states, 1785–1851) created a paper music recorder in 1812 and then the first keyboard typewriter in 1821, [Ebeling 1985; Lessing 2003, 2010; Michael Rauck 1983]. He also invented the first bicycle (p. 1491).

In the English-speaking world, credit for producing the first practical typewriters has traditionally been assigned primarily to Christopher Latham Sholes (U.S., 1819–1890), Carlos Glidden (U.S., 1834–1877), and James Densmore (U.S., 1820–1889), who marketed what became known as Remington typewriters beginning in the 1870s.

In fact, the first practical typewriters were invented and demonstrated a decade earlier by Peter Mitterhofer (Austrian, 1822–1893). Building upon the earlier work by Karl von Drais, Mitterhofer produced his first model in 1864. Mitterhofer created a series of improved models in rapid succession after that until around 1869 [Lassnig 1993; Technisches Museum Wien 2005; Waize 2003]. See Fig. 7.3. Lutz Rolf, an historian of science at the Berlin Technical University, explained how innovative Mitterhofer’s work was [Technisches Museum Wien 2005, pp. 108–110]:

The basic concept of Mitterhofer’s models thus builds on the idea that all functions of the machine can be controlled by the keyboard. Even the cylindrical paper carrier mechanism used in the later models, which cleverly automated line spacing and the return of the platen, subscribes to this concept. [...]

Mitterhofer's overall aim was to replace handwriting with a mechanised process derived from printing. As new technical solutions needed to be developed and combined for a vast range of different functional elements, a stepwise approach was adopted. Mitterhofer built several different models to experiment with, which he kept adding to and improving on in order to achieve his overall aim. [...]

His design incorporates features that other typewriters were only to offer much later and was the most advanced typewriter of its time. Even from today's vantage point, some of the solutions Mitterhofer came up with for individual problems can still be regarded as the best possible.

Mitterhofer's work was decisively influenced by the fact that, apart from creative talent, he also possessed remarkable technical skill and experience as well as a talent for improvisation. In addition, he also built his models himself. He was thus able to put his ideas into practice and test them directly. This may also be why, despite the sheer scope of detail solutions required and the host of construction problems he encountered, it only took him six years to create his machine, from the initial idea to the production of the prototype. The development of Sholes and Glidden's design, by comparison, which was embarked on much later, involved a great number of engineers and technicians who needed more than a decade to produce a machine comparable to Mitterhofer's creation.

As it turns out, even the Sholes/Remington typewriters that appeared a decade later in the United States were designed and built by German mechanics (Fig. 7.4). Sholes, Densmore, Remington, and their fellow financial backers wanted a typewriter that they could mass-produce and sell. However, for the actual design, development, and construction of suitable typewriters, they hired a machine shop owned and staffed by German-speaking and German-trained mechanics who had immigrated to the United States, and run by Carl Friedrich Kleinsteuber (German, 1822–1885). Kleinsteuber appointed a team led by Mathias Schwalbach (German, 1834–1920), who ultimately had a long career designing and building many clever machines, such as very sophisticated sewing machines, clocks, and watches [<https://oztypewriter.blogspot.com/2011/09/on-this-day-in-typewriter-history-cxxii.html>]. Schwalbach, Kleinsteuber, and others on the team used their own mechanical knowledge, and presumably also designs such as Mitterhofer's coming out of Europe, in order to design their typewriters. They produced a prototype in 1872 and then a series of improved versions after that, which Sholes and Remington began selling in the mid-1870s. The U.S.-born sponsors claimed most of the public credit for the line of typewriters, whereas the German-born creators were largely forgotten.

**Johannes Gutenberg (c. 1400–1468) invented printing press (c. 1436)****Gutenberg printed Bible (c. 1452)**

Figure 7.1: Johannes Gutenberg invented the printing press around 1436.



**Karl von Drais  
(1785–1851)**

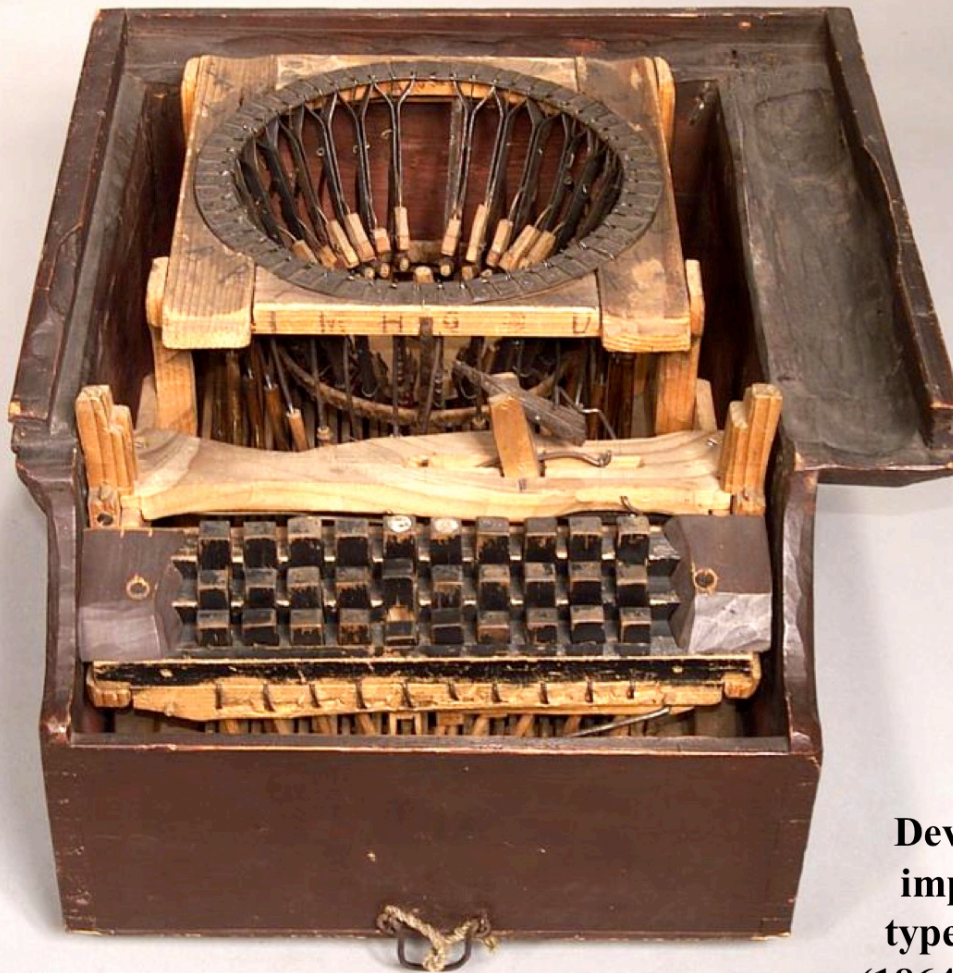


**Paper music recorder (1812)**

**First keyboard typewriter (1821)**

Figure 7.2: Karl von Drais created a paper music recorder in 1812 and the first keyboard typewriter in 1821.

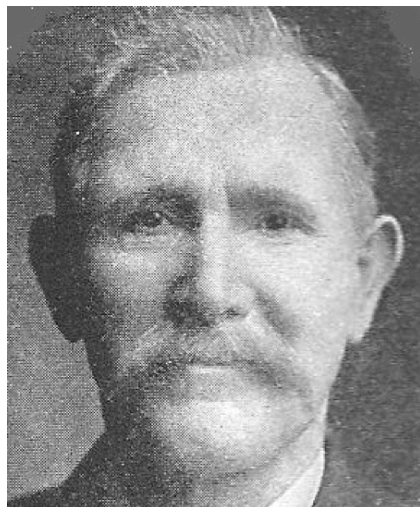
**Peter Mitterhofer**  
(1822–1893)



**Developed  
improved  
typewriters  
(1864 onward)**

Figure 7.3: Peter Mitterhofer produced a series of improved typewriters from 1864 onward.





**Mathias Schwalbach (1834–1920) and other German-speaking mechanics at the machine shop of Carl Friedrich Kleinsteuber (1822–1885) developed improved typewriters (1872 onward)**



**C. L. SHOLES & M. SCHWALBACH.**  
**TYPE WRITING MACHINE.**  
 No. 182,511. Patented Sept. 19, 1876.

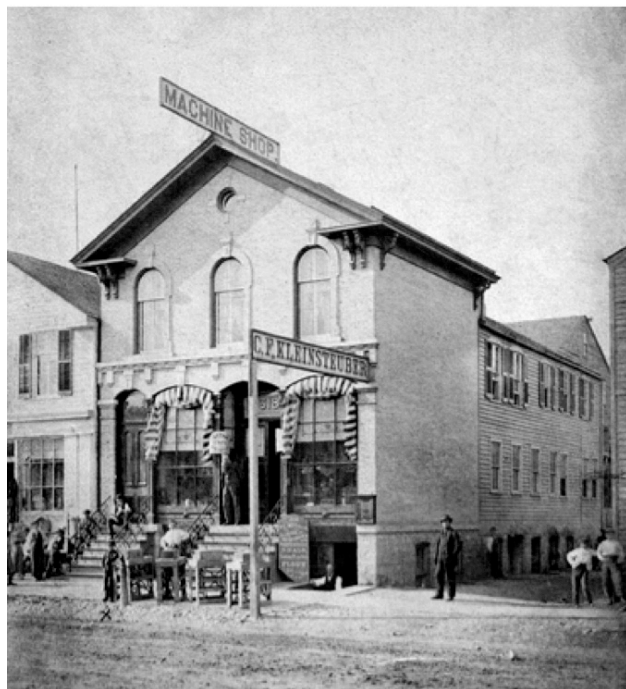
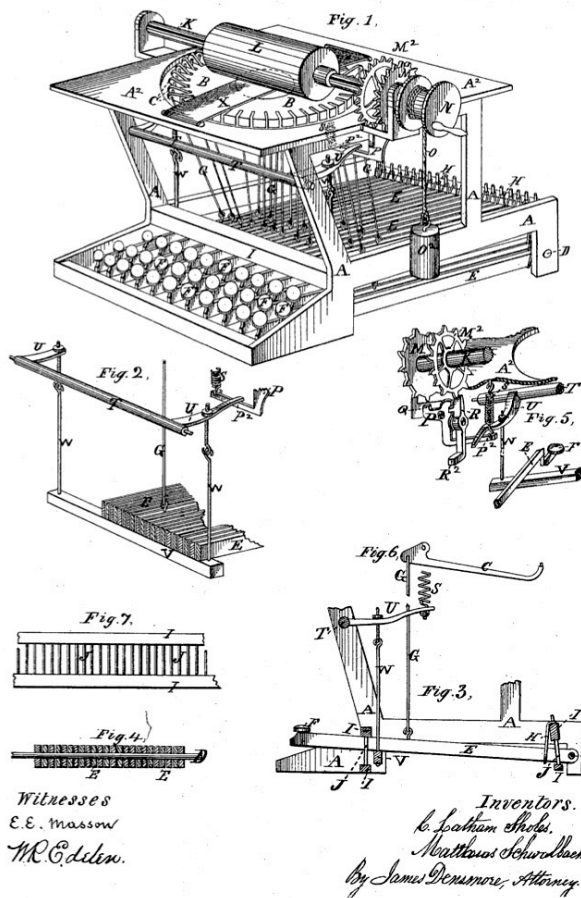


Figure 7.4: Mathias Schwalbach developed an improved typewriter in 1872.

### 7.1.3 Stationery Supplies

In 1844, Friedrich Gottlob Keller (German, 1816–1895) invented a wood-grinding machine for mass-producing paper (Fig. 7.5). Prior to that time, paper had been made from cloth rags, which were in short supply and therefore greatly limited the maximum production rate and minimum cost of paper. Machines based on Keller’s design revolutionized the production of paper and quickly became used worldwide.

As shown in Fig. 7.6, the Hungarian brothers László Bíró (1899–1985) and György Bíró (18??–19??) developed the ballpoint pen during the period 1931–1938. The science historian Felix Paturi described their invention [Paturi 1998, p. 529]:

“Kuli” revolutioniert das Schreiben

“Pen” revolutionizes writing

Die ungarischen Brüder Ladislao und Georg Biró erfinden den Kugelschreiber.

The Hungarian brothers László and György Bíró invent the ballpoint pen.

Das Grundprinzip des neuen Schreibgeräts ist einfach: Ein länglicher, im Griff eingearbeiteter Behälter (Mine) ist mit Tinte gefüllt. An ihrem vorderen Ende läuft die Mine konisch zu und wird durch eine kleine Kugel abgedichtet, die sich in einer Lagerpfanne drehen kann. Führt man den Stift mit der Kugel über Papier, befördert sie durch Rotation etwas Tinte aus der Mine auf die Schreibfläche. Die technischen Schwierigkeiten liegen zunächst in der Entwicklung einer geeigneten zähflüssigen und schnell trocknenden Tinte. Nachdem die Biró-Brüder eine solche Schreibflüssigkeit entwickelt haben, ist der weltweite Siegeszug des “Kulis” nur noch eine Frage der Zeit.

The basic principle of the new writing instrument is simple: an elongated container (refill) incorporated into the handle is filled with ink. At its front end, the refill tapers and is sealed by a small ball that can rotate in a bearing cup. When the ball and pen are placed over paper, the ball rotates and transports some ink from the refill to the writing surface. The technical difficulties initially lie in the development of a suitable viscous and quick-drying ink. Now that the Bíró brothers have developed such a writing fluid, the worldwide triumphal march of the “Kulis” is only a matter of time.

Friedrich Soennecken (German, 1848–1919) invented the paper hole punch and ring binders for hole-punched papers in 1886 [Hellbeck 2008]. See Fig. 7.7.



**Friedrich  
Gottlob  
Keller  
(1816–1895)  
invented a  
wood-grinding  
machine for  
mass-producing  
paper (1844)**

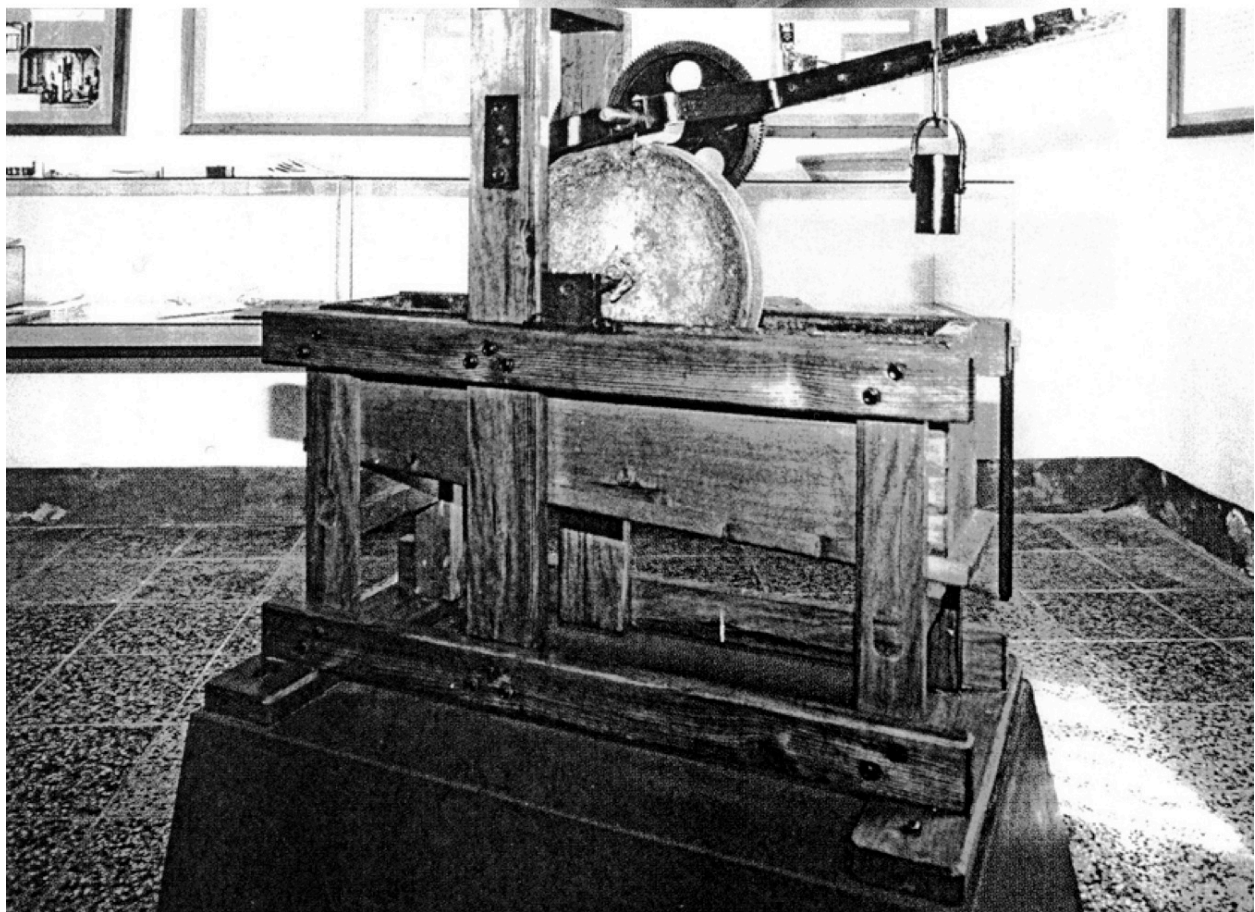


Figure 7.5: In 1844, Friedrich Gottlob Keller invented a wood-grinding machine for mass-producing paper.

**László Bíró**  
**(1899–1985)**

**Developed ballpoint pen**  
**(1931–1938)**



**György Bíró**  
**(18??–19??)**



Figure 7.6: The brothers László and György Bíró developed the ballpoint pen 1931–1938.

**Invented paper hole punch (1886)**



**Friedrich Soennecken  
(1848–1919)**



**Invented ring binder for  
hole-punched papers (1886)**



Figure 7.7: Friedrich Soennecken invented the paper hole punch and ring binders for hole-punched papers in 1886.



### 7.1.4 Improved Printing Processes

Beginning in 1796, Alois Senefelder (Austrian/German states, 1771–1834) developed lithography for printing illustrations, as shown in Fig. 7.8. The *Encyclopedia Britannica* explained how Senefelder developed his invention [EB 2010]:

German inventor of lithography. [...] Desiring to publish plays that he had written but unable to afford the expensive engraving of printing plates, Senefelder tried to engrave them himself. His work on copper plates was not proving very successful when an accident led to his discovery of the possibilities of stone (1796). Senefelder records that one day he jotted down a laundry list with grease pencil on a piece of Bavarian limestone. It occurred to him that if he etched away the rest of the surface, the markings would be left in relief. Two years of experimentation eventually led to the discovery of flat-surface printing (modern lithography).

After using single lithography plates to reproduce black-and-white illustrations in his early work, by 1818 Senefelder had developed methods to use multiple lithography plates with different colors of ink to make color illustrations [Bunch and Hellemans 2004, p. 306]. Very similar lithographic techniques of protecting and etching different parts of surfaces are now also widely used to make semiconductor devices (Section 6.5).

Friedrich König (German states, 1774–1833) and Andreas Bauer (German states, 1783–1860) developed the steam-powered printing press in 1814 [Halkasch 1993; Kasischke 1999; Max Rößler 1982; Wolf 1974]. See Fig. 7.9.

Paul Pretsch (German?, 18??–19??) and A. J. Berchtold (German?, 18??–19??) did early work and Georg Meisenbach (German, 1841–1912) perfected the halftone method for reproducing photographs with tiny printed dots [Dorothea Peters 2007]. Figure 7.10 shows the first image that Meisenbach produced with his final halftone method. This method is still widely used for newspapers, magazines, and computer printers.

As shown in Fig. 7.11, Ottmar Mergenthaler (German, 1854–1899) was born and educated in Germany, then emigrated to the United States. During the period 1876–1899, he developed linotype machines for rapid typesetting for printing presses [Schlesinger 1989]. Oxford University’s *Biographical Dictionary of Scientists* described the mechanism and importance of Mergenthaler’s invention [Porter 1994, p. 478]:

Before Linotype, printing was carried out by hand-setting, a long and laborious process. Mergenthaler’s invention speeded this operation and made printed matter, from books to penny news sheets, cheaper to produce. The design of the machine enabled a line of type (hence the name) to be composed at one time and cast as a single piece of metal. The machine was rather like a large typewriter, about 2 m/6½ ft high, with a store of matrices (moulds) at the top. The operator selected the letters by means of rods controlled by the ‘typewriter’ keys, and these letters fell through tiny trapdoors to drop into position in a line setting. As each line was completed it was passed on to the ‘metal pot’ area where a cast was made to form a ‘slug’ with the letters in relief on one side.

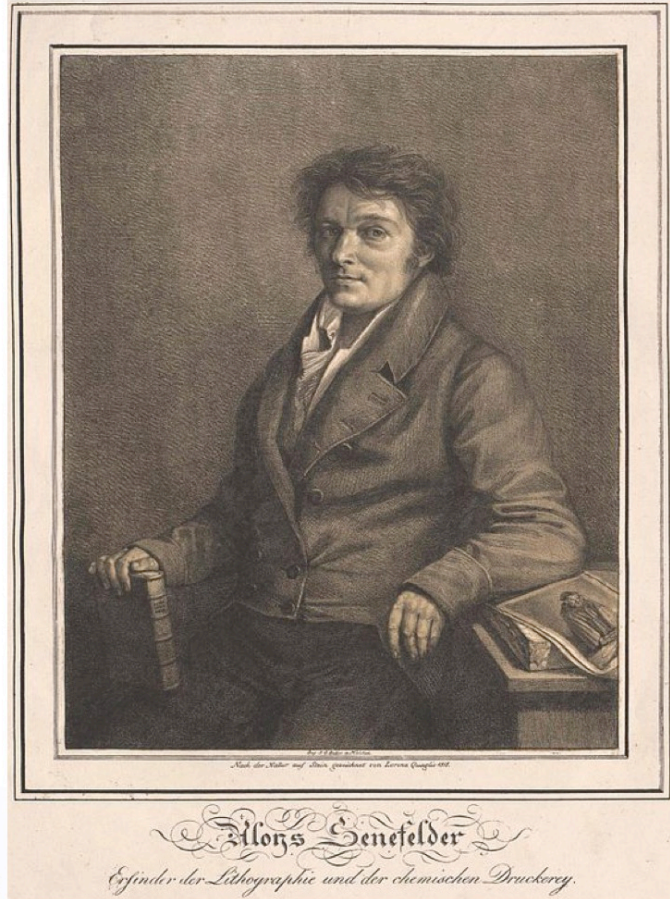
This then fitted into a page of type ready for printing, while the matrices were returned to the store at the top of the machine for reuse.

A person operating one of Mergenthaler's keyboards could set type up to three or four times faster than by hand-setting, cutting the labour cost of production to a fraction of before. The machine heralded a new age for printing in which books became affordable, and newspapers could really claim to carry up-to-the-minute information, for the Linotype made it possible to change and reset copy to within minutes of going to press.

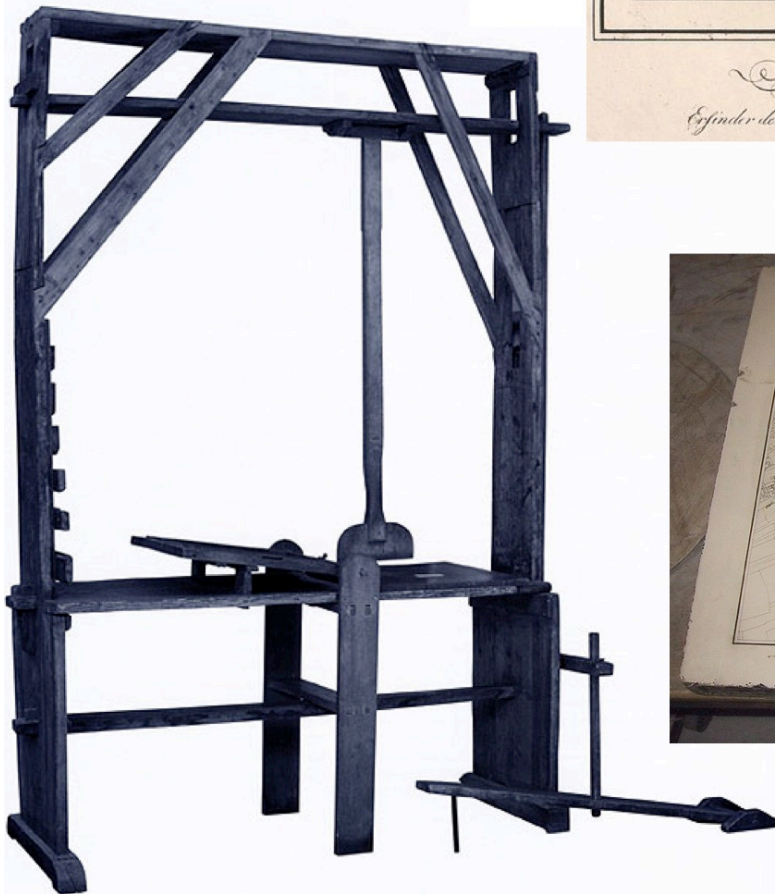
The German-speaking world developed advanced methods of printing that were transferred to other countries after World War II. See Fig. 7.12 for just one example among many [NARA RG 40, Entry UD-75, Box 3, Folder Press Releases].

See also pp. 1013 and 1162 for German-speaking contributions to electronic technologies for document printing, document transfer, and document storage.

**Lithograph of  
Alois Senefelder  
(1771–1834)**



**Lithography press**



**Lithography plate**



Figure 7.8: Alois Senefelder developed lithography for printing illustrations beginning in 1796.





**Friedrich König  
(1774–1833)**

**Andreas Bauer  
(1783–1860)**

**Developed steam-powered  
printing press (1814)**

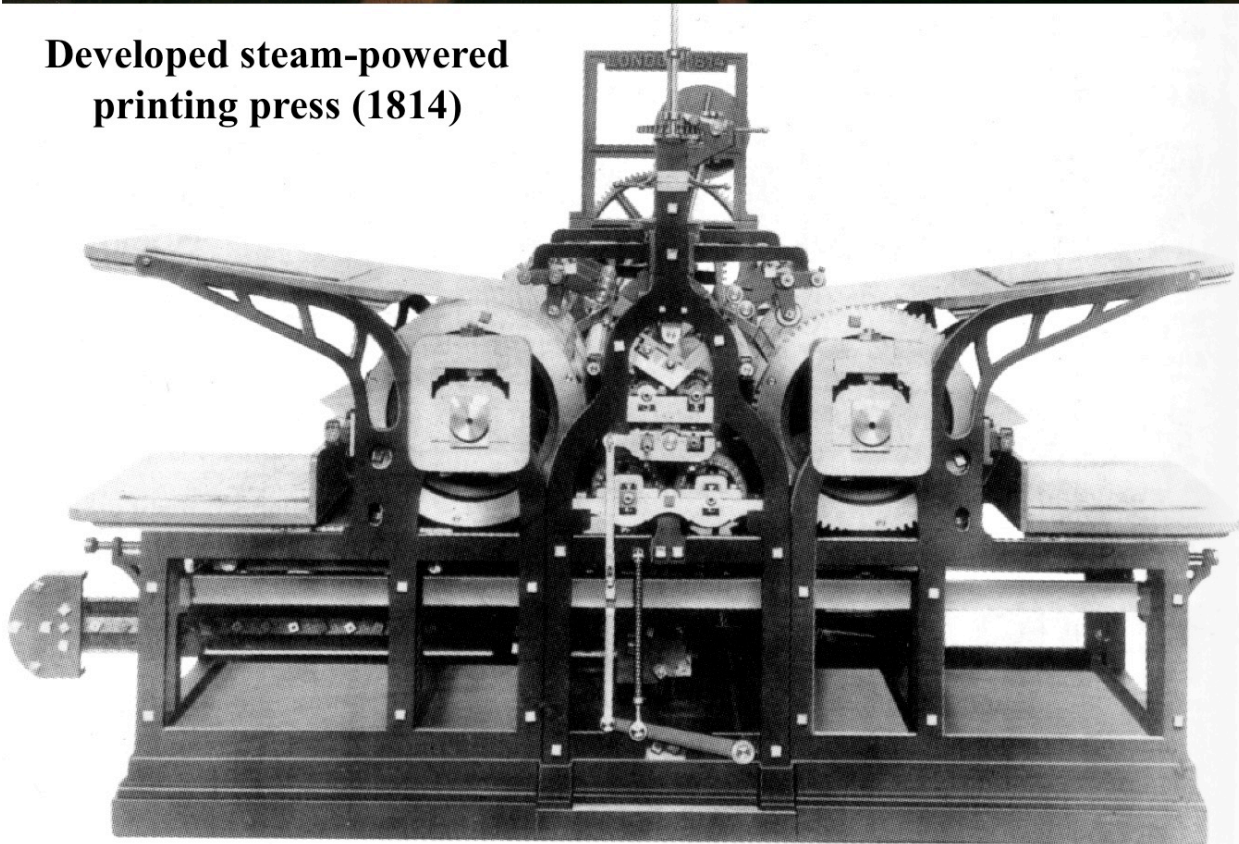


Figure 7.9: Friedrich König and Andreas Bauer developed the steam-powered printing press in 1814.

**Paul Pretsch**  
**(18??–19??)**  
**Halftone**  
**experiments (1854)**

**A. J. Berchtold**  
**(18??–19??)**  
**Halftone**  
**improvements (1855)**

**Georg Meisenbach**  
**(1841–1912)**  
**Reliable halftone**  
**process (1882)**



### **Halftone method for reproducing photographs with tiny printed dots**



Figure 7.10: Paul Pretsch and A. J. Berchtold did early work and Georg Meisenbach perfected the halftone method for reproducing photographs with tiny printed dots.



**Ottmar Mergenthaler  
(1854–1899)  
developed  
linotype machines  
for rapid typesetting  
for printing presses  
(1876–1899)**

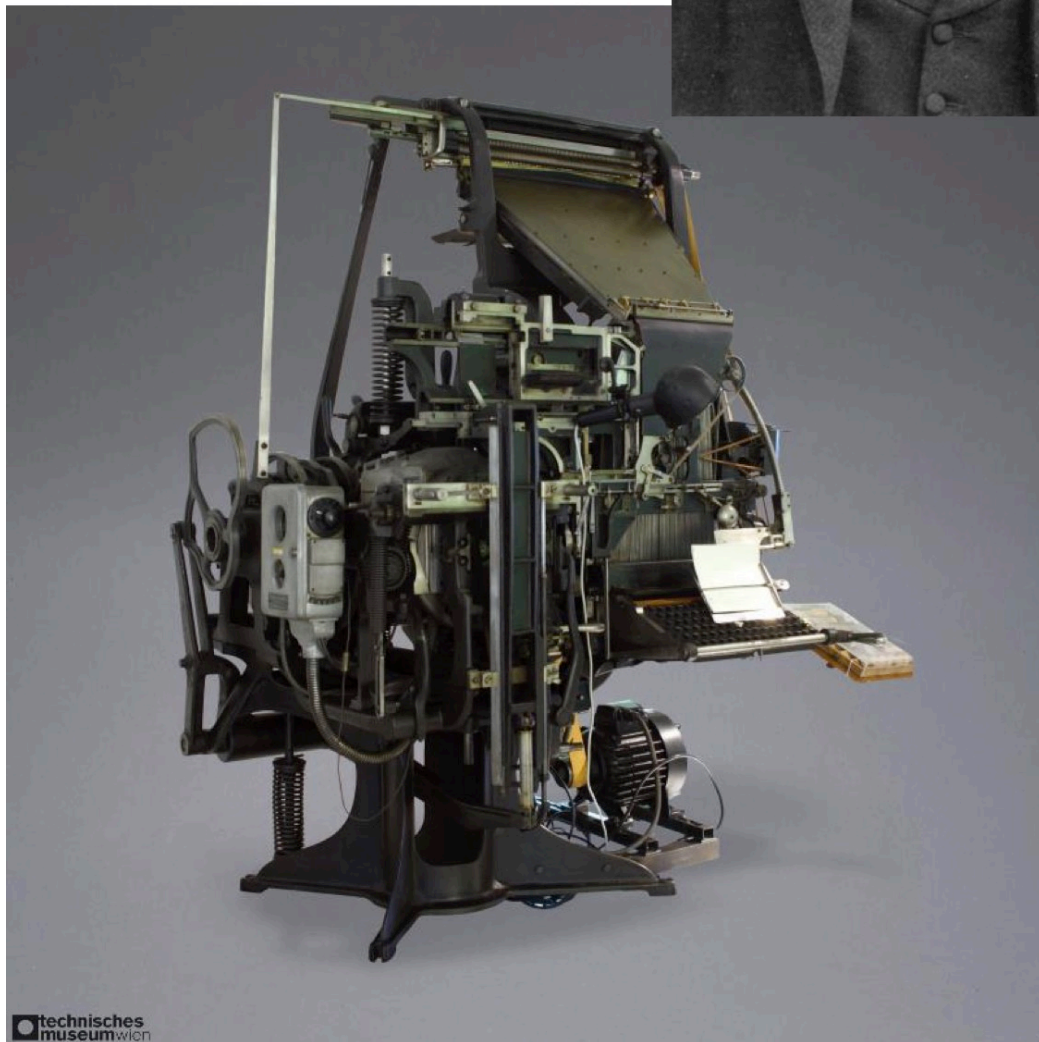
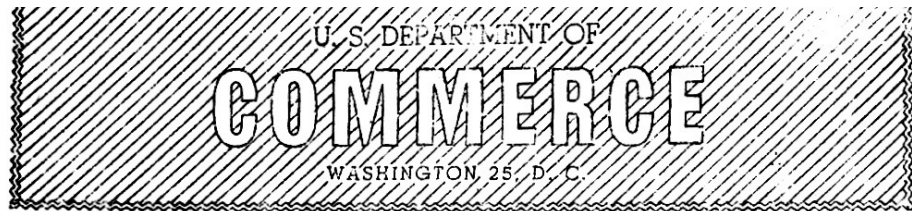


Figure 7.11: Ottmar Mergenthaler developed linotype machines for rapid typesetting for printing presses (1876–1899).



Karasik-Ext. 1006  
 Advance Release For  
 Monday, November 25, 1946

OTS 494

OFFICE OF TECHNICAL SERVICES

Bimetallic printing plates developed by the Germans, said to be good for more than a million impressions in printing bank notes, are described in a report now on sale by the Office of Technical Services, Department of Commerce.

The 59-page report, prepared by British printing industry experts for the British Intelligence Objectives Sub-Committee, describes the operation of 18 German printing and printing supply firms.

The bimetallic plates are made of brass with nickel-steel electro-deposited over the non-printing areas. Re-nickeling of the plate after a run of 200,000 is recommended. The plates are said to be economical in the use of ink and to make possible greater continuity in large printing runs. Speeds of 10,000 to 15,000 impressions an hour are claimed.

Other noteworthy developments described in the report are:

Recent advances in the "Eggen" and "Efha" processes for deep etching of lithographic plates.

Light plastic spacing furniture, made by injection molding, said to be in regular use for letter press printing.

Heat treatment of a cellulose varnish to produce a high finish on show cards.

Book binding techniques, including wire book sewing machines which are widely preferred to thread sewing in Germany.

Printing machines, producing up to 4 colors on one side with one color on the reverse and operating at speeds up to 3,000 sheets an hour.

"Aktophot" projection camera and other photocopying apparatus.

Manufacture of gravure inks with a water base.

Use of "Astrolon", a celluloid-like vinyl chloride sheet, for measuring scales, rulers and protractors, as well as bases for originals in photolithography and other photo reproduction work.

Klimsch "Stator" machine, claimed to be rapid and economical for applying an even emulsion coating to photosensitive plates.

A dry collodion process for 3 or 4 color separations.

"Unfortunately, this report gives little working detail on many points", commented Robert Reiss, chief of OTS' Technical Industrial Intelligence Division. "More intensive studies of the German printing industry are still possible, however. TIID can arrange for American experts to visit plants described in this report and other important industrial targets. Individuals and firms interested in sending investigators to Germany should communicate with OTS immediately."

Orders for the report (German Printing Industry; PB-34044; photostat, \$4; microfilm, \$2; 59 pages), should be addressed to the Office of Technical Services, Department of Commerce, Washington 25, D. C., and should be accompanied by check or money order payable to the Treasurer of the United States.

NARA RG 40, Entry UD-75,  
 Box 3, Folder Press Releases

Figure 7.12: The German-speaking world developed advanced methods of printing that were transferred to other countries after World War II [NARA RG 40, Entry UD-75, Box 3, Folder Press Releases].

## 7.2 Musical Instruments

The quantity and quality of musical contributions by composers from the predominantly German-speaking central European world are well known. Composers such as those listed in Table 7.1 remain household names worldwide, even centuries later.

Name	Nationality	Lived
Johann Sebastian Bach	German states	1685–1750
Carl Philipp Emanuel Bach	German states	1714–1788
Johann Christian Bach	German states	1735–1782
Ludwig van Beethoven	German states	1770–1827
Alban Berg	Austrian	1885–1935
Johannes Brahms	German	1833–1897
Josef Anton Bruckner	Austrian	1824–1896
Fryderyk Chopin	Polish	1810–1849
Antonín Dvořák	Czech/Austrian	1841–1904
Christoph Willibald Gluck	German states/Austrian	1714–1787
Georg Friederich Handel	German states	1685–1759
Joseph Haydn	Austrian	1732–1809
Michael Haydn	Austrian	1737–1806
Paul Hindemith	German	1895–1963
Leoš Janáček	Czech/Austrian	1854–1928
Franz Liszt	Austro-Hungarian	1811–1886
Gustav Mahler	Austrian	1860–1911
Fanny Mendelssohn	German states	1805–1847
Felix Mendelssohn	German states	1809–1847
Leopold Mozart	Austrian	1719–1787
Wolfgang Amadeus Mozart	Austrian	1756–1791
Carl Orff	German	1895–1982
Johann Pachelbel	German states	1653–1706
Arnold Schoenberg	Austrian	1874–1951
Franz Schubert	Austrian	1797–1828
Robert Schumann	German states	1810–1856
Clara Schumann	German	1819–1896
Heinrich Schütz	German states	1585–1672
Bedřich Smetana	Czech/Austrian	1824–1884
Johann Strauss	Austrian	1825–1899
Richard Strauss	German	1864–1949
Georg Philipp Telemann	German states	1681–1767
Richard Wagner	German	1813–1883
Carl Maria von Weber	German states	1786–1826
Anton Webern	Austrian	1883–1945
Kurt Weill	German	1900–1950

Table 7.1: Examples of well-known musical composers from the predominantly German-speaking central European world.

While it is less well known to the general public, German-speaking creators also made enormous contributions to the development of modern musical instruments and equipment, including:<sup>3</sup>

7.2.1. Woodwind instruments

7.2.2. Brass instruments

7.2.3. Pianos

7.2.4. Metronomes

### 7.2.1 Woodwind Instruments

As shown in Fig. 7.13, Johann Christoph Denner (German states, 1655–1707) developed the clarinet around 1700. Iwan Müller (Baltic German, 1786–1854) later created airtight key pads for it and other woodwinds. Anthony Baines, an Oxford University musicologist and curator of musical instruments, praised Denner’s creation [Baines 1991, p. 297]:

The clarinet, Germany’s great contribution to the woodwind, marks the first full exploitation in Western musical history—possibly in all history—of the upper register of a reed-sounded cylindrical tube. It was invented about the beginning of the eighteenth century by J. C. Denner of Nuremberg or his son. Doppelmeyr’s ‘Historical Report of Nuremberg Mathematicians and Craftsmen,’ 1730, names the father.

Denner was one of the leading German woodwind-makers of the end of the seventeenth century[...]

Although simple flutes had been used since antiquity, Theobald Böhm (German, 1794–1881, Fig. 7.14) developed the modern Western concert flute during the period 1831–1847. Anthony Baines explained some of the steps that Böhm went through to perfect his flute design [Baines 1991, pp. 320–322]:

When Boehm returned to Munich, his keen, analytical mind faced up squarely to the question of the large holes, and he quickly decided to incorporate them on a systematic basis throughout the instrument. Moreover, he went yet a step further: he conceived the idea of securing *full venting* for the notes by changing all the existing closed keys into open keys—i.e. into keys standing normally open.

This reversed key-system demanded some novel method of control, and for this Boehm embodied a mechanical device that had appeared already in rudimentary forms in the workshops of other experimental flute-makers: the now-familiar rings, through which a finger can operate a key in the same movement as closing its own hole. Thus he produced the *conical Boehm flute*, 1832, the greatest of all landmarks in the modern history of woodwind design. [...]

Search for yet greater volume and freedom of sound led Boehm next to reason thus, assisted by experiments with numerous bits of brass tubing[...]

---

<sup>3</sup>Baines 1991, 1993; Ulrich Michels 2008; Sachs 1940; Wilkinson 2014.

With this, Boehm had found his *cylindrical bore* (1847), the bore of the flute today. The holes, he discovered, should have at least three-quarters of the diameter of the bore, making covered action (finger-plates) necessary. Hole I was an exception to the rule: for the sake of the upper D's it had to be smaller than the other holes, and placed rather high up the flute. Boehm's first instruments were of silver, though late in life he himself changed to wood, or silver with wooden head.

The modern oboe (sometimes called the Wiener or Viennese oboe) was developed in stages by Johann Eichentopf (German states, 1678–1769), Jacob Denner (German states, 1681–1735), Stefan Koch (Austrian, 1772–1828), Karl Friedrich Golde (German, 1803–1873), Josef Hajek (Austrian, 1849–1926), and Hermann Zuleger (Austrian, 1885–1949). See Fig. 7.15.

The modern bassoon (sometimes called the Heckel bassoon) was developed by Gottfried Weber (German states, 1779–1839), improved by Carl Almenröder (German states, 1786–1846), and perfected by Johann Adam Heckel (German, 1812–1877), as illustrated in Fig. 7.16. Anthony Baines described the contributions of Almenröder and Heckel [Baines 1991, pp. 338–339]:

The story of the Heckel bassoon begins about 1825, when Carl Almenraeder, a bandmaster and contemporary of the Savarys, set out to cure certain faults of the classical bassoon. [...]

Thus far, Almenraeder was entirely successful, producing an instrument on which the notes came out as steadily and evenly as they do on the small woodwind. But the tone-quality suffered. [...] It has been the achievement of the firm of Heckel to undo the damage to the tone while yet preserving the technical benefits. The work included patient attention to the bore [...] and refinement of the manufacture by every possible means. During one period, Wagner himself was in and out of the workshop watching progress with keen interest.

The harmonica was created around 1821 in the German-speaking world and then copied so rapidly by several craftsmen there that it is unclear which one of them actually originated the instrument (Fig. 7.17). Proposed creators of the harmonica include Christian Friedrich Buschmann (German states, 1805–1864), Anton Häckl (Austrian, 17??–18??), Georg Anton Reinlein (Austrian, 1766–1834), and Joseph Richter (Austrian, 17??–18??).

In a very similar fashion, the accordion was developed around 1822 in the German-speaking world and immediately copied by craftsmen there. Proposed creators of the accordion include the same Christian Friedrich Buschmann, Cyrill Demian (Austrian, 1772–1849), and Carl Friedrich Uhlig (German, 1789–1874, inventor of the concertina). See Fig. 7.18. The *Encyclopedia Britannica* summarized some of what is known of the origins of the accordion [EB 2010]:

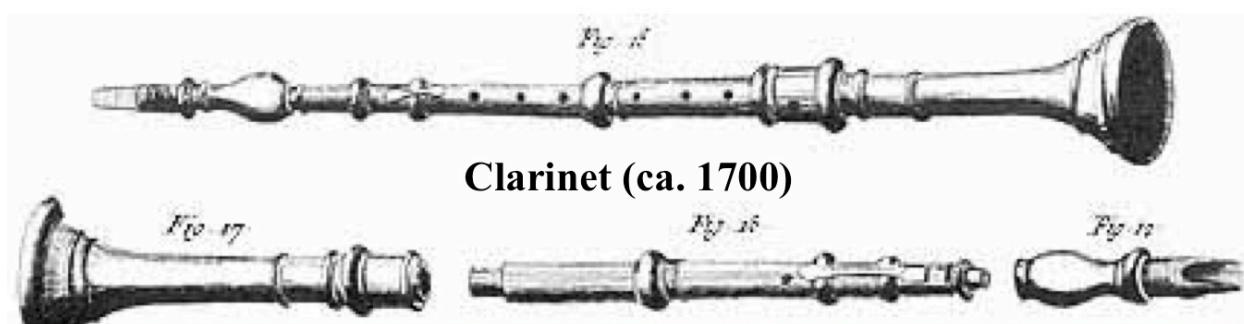
The advent of the accordion is the subject of debate among researchers. Many credit C. Friedrich L. Buschmann, whose *Handäoline* was patented in Berlin in 1822, as the inventor of the accordion, while others give the distinction to Cyrill Demian of Vienna, who patented his *Accordion* in 1829, thus coining the name. A modification of the *Handäoline*, Demian's invention comprised a small manual bellows and five keys, although, as Demian noted in a description of the instrument, extra keys could be incorporated into the design. Numerous variations of the device soon followed.



**Johann  
Christoph  
Denner  
(1655–1707)**



**Iwan Müller  
(1786–1854)**



**Clarinet (ca. 1700)**



Figure 7.13: Johann Christoph Denner developed the clarinet around 1700, and Iwan Müller created airtight key pads for it and other woodwinds.



**Theobald Böhm**  
**(1794–1881)**

**Western concert flute**  
**(1847)**

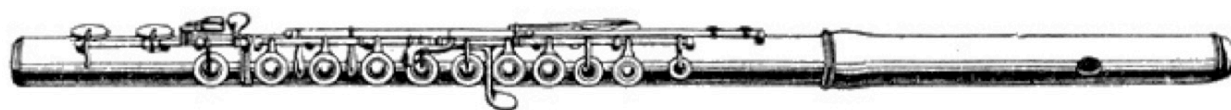


Figure 7.14: Theobald Böhm developed the modern Western concert flute during the period 1831–1847.

**Johann Eichentopf**  
(1678–1769)

**Jacob Denner**  
(1681–1735)

**Stefan Koch**  
(1772–1828)

**Karl Friedrich Golde**  
(1803–1873)

**Josef Hajek**  
(1849–1926)

**Hermann Zuleger**  
(1885–1949)

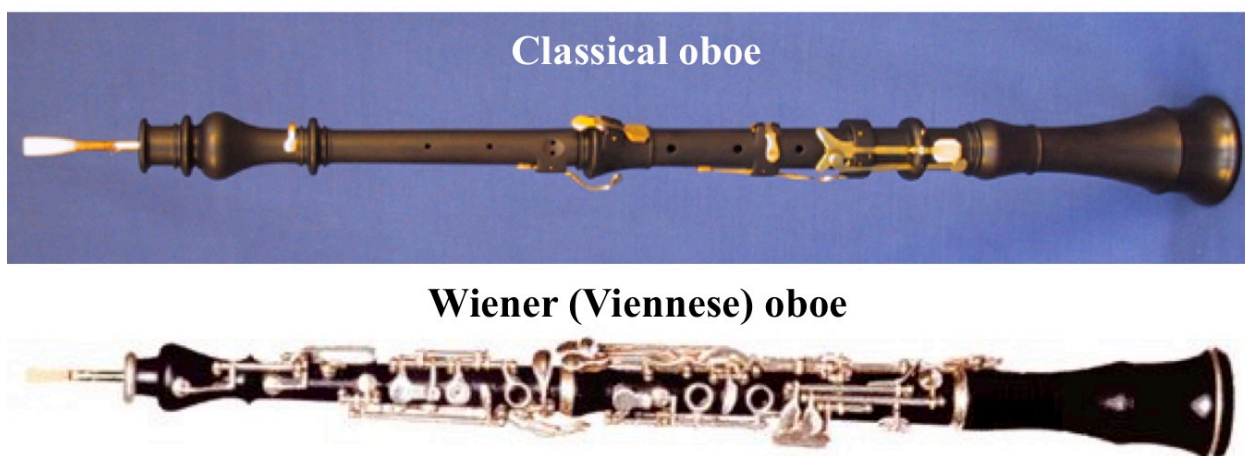


Figure 7.15: The modern oboe (sometimes called the Wiener or Viennese oboe) was developed in stages by Johann Eichentopf, Jacob Denner, Stefan Koch, Karl Friedrich Golde, Josef Hajek, and Hermann Zuleger.



**Gottfried Weber**  
(1779–1839)



**Carl Almenräder**  
(1786–1846)

**Johann Adam Heckel**  
(1812–1877)

**Heckel bassoon**



Figure 7.16: The modern bassoon (sometimes called the Heckel bassoon) was developed by Gottfried Weber, Carl Almenräder, and Johann Adam Heckel.

**Christian Friedrich Buschmann**  
(1805–1864)

**Anton Häckl**  
(17??–18??)

**Georg Anton Reinlein**  
(1766–1834)

**Joseph Richter**  
(17??–18??)

**Harmonica (ca. 1821)**



Figure 7.17: The harmonica was developed around 1821 in the German-speaking world and rapidly copied by several craftsmen there. Proposed creators of the harmonica include Christian Friedrich Buschmann, Anton Häckl, Georg Anton Reinlein, and Joseph Richter.

**Christian Friedrich  
Buschmann (1805–1864)**

**Cyrill Demian  
(1772–1849)**

**Carl Friedrich Uhlig  
(1789–1874)**

**Accordion (ca. 1822)**



Figure 7.18: The accordion was developed around 1822 in the German-speaking world and rapidly copied by several craftsmen there. Proposed creators of the accordion include Christian Friedrich Buschmann, Cyrill Demian, and Carl Friedrich Uhlig.

### 7.2.2 Brass Instruments

Anton Joseph Hampel (Austrian/German states, 1710–1771) invented tuning slides for brass horns in 1753 or earlier. See Fig. 7.19.

Friedrich Blühmel (German states, 1777–1845) and/or Heinrich Stölzel (German states, 1777–1844) created valves for brass horns around 1813 (Fig. 7.19). Anthony Baines explained what is known of their history [Baines 1993, pp. 206–207]:

In 1815 the *Allgemeine musikalische Zeitung* printed the historic communication from Breslau [...], signed by the director of the theatre there:

#### NEW INVENTION

Kammermusikus Heinrich Stölzel of Pless in Upper Silesia has, for the perfection of the *Waldhorn*, devised a simple mechanism by which a chromatic scale of nearly three octaves, with all non-natural notes clear and strong, and similar in sound to the natural notes, is obtained by means of two levers for the right hand. [...]

Heinrich Stoelzel (as he was sometimes more conveniently spelt) was then a thirty-eight year old horn-player in the orchestra of Prince von Pless. At once he began to advertise the new horn, performing on it at Leipzig in 1817[...] Next year he found himself a place in the royal orchestra at Berlin. He had, however, left out of the reckoning his younger collaborator, Friedrich Blühmel, a member of the miners' band (*Berg-Hoboist*) and for all we know a horn-player too. Blühmel chased to Berlin, to claim that the horn had been his and sold by him to Stoelzel. A ten-year Prussian patent was then issued in 1818 jointly to the two men ([...] both are described as coming from Waldenburg, today Walbrzych, southwest of Breslau, where Pless had a castle). [...] Stoelzel finally bought off Blühmel on the expiry of the patent. Both were evidently mechanics as well as musicians. But the only writer who knew them both personally, the great Berlin bandmaster Wilhelm Wieprecht, said that though the two men had worked together in Silesia for many years, their subsequent quarrels made it quite impossible to find out which of them had conceived the idea first.

Those two mechanical inventions—tuning slides and valves—revolutionized the entire family of brass musical instruments.

Wilhelm Friedrich Wieprecht (German, 1802–1872) and Johann Gottfried Moritz (German states, 1777–1840) invented the tuba in 1835. Moritz's son, Carl Wilhelm Moritz (German states, 1810–1855), created the tenor tuba in 1838. See Fig. 7.20. Anthony Baines wrote [Baines 1993, p. 250]:

Still early in the period of these bombardons, Moritz and Wieprecht, in or just before 1835, produced their *Bass-tuba*. This very compact but rather heavy F bass has a valve bore of 15.5 mm. [...] Moritz's tuba won much admiration and must surely have been envisaged by Wagner in the opening of the *Faust* Overture, which no contemporary bombardon could have managed.

Edmund Gumpert (German, 18??–19??) and Friedrich Kruspe (German, 18??–19??) invented the modern double horn, sometimes called the “French” horn, in 1897, as illustrated in Fig. 7.21.



**Anton Joseph Hampel  
(1710–1771)**

**Friedrich Blümel  
(1777–1845)**

**Heinrich Stölzel  
(1777–1844)**

**Tuning slides for  
brass horns (1753)**

**Valves for brass horns (ca. 1813)**



Figure 7.19: Anton Joseph Hampel invented tuning slides for brass horns in 1753 or earlier. Friedrich Blümel and/or Heinrich Stölzel created valves for brass horns around 1813.

**Wilhelm Friedrich  
Wieprecht  
(1802–1872)**

**Johann Gottfried  
Moritz  
(1777–1840)**

**Carl Wilhelm  
Moritz  
(1810–1855)**



Figure 7.20: Wilhelm Friedrich Wieprecht and Johann Gottfried Moritz invented the tuba in 1835. Moritz's son, Carl Wilhelm Moritz, created the tenor tuba in 1838.



**Edmund Gumpert  
(18??–19??)**

**Friedrich Kruspe  
(18??–19??)**

**Double horn or French horn (1897)**



Figure 7.21: Edmund Gumpert and Friedrich Kruspe invented the modern double horn or French horn in 1897.

### 7.2.3 Pianos

Early pianos first evolved from harpsichords and clavichords, apparently in Italy, but then a series of German-speaking creators made numerous mechanical innovations to develop modern pianos (Fig. 7.22). Some of the major creators included Gottfried Silbermann (German states, 1683–1753), Christoph Gottlieb Schröter (German states, 1699–1782), Christian Ernst Friederici (German states, 1709–1780), Johann Christoph Zumpe (German states, 1726–1790), Johann Andreas Stein (German states, 1728–1792), and Johann Heinrich Pape (German states, 1789–1875). Musicologist Curt Sachs emphasized the dominance of German-speaking creators in the development of pianos [Sachs 1940, pp. 393–395]:

Italy invented the piano, but then abandoned it. The Germans adopted the art and evolved and transformed the piano; for the following forty years pianos were made exclusively in Germany.

The first and best early maker of grand pianos in Germany was the famous organ builder GOTTFRIED SILBERMANN, of Freiberg, Saxony. He was well acquainted with Johann Sebastian Bach, who criticized and advised him in his attempts, and Frederick the Great of Prussia bought three of the pianos which are now in Potsdam palaces. [...]

This simple action was given an escapement about the year 1770, probably by JOHANN STEIN in Augsburg. In 1777, Wolfgang Amadeus Mozart wrote to his father that he had called on Stein's workshop. "His instruments distinguish themselves by an escapement; not one in a hundred makers troubles himself about that; but without an escapement a piano clatters and leaves a sound[...]" This action with an escaping hammer connected with the key was called first the *German action*, and later on, when the STEIN family had moved to Vienna, the *Viennese action*. [...]

In 1760 a dozen Saxon piano makers, jobless on account of the Seven Years' War, came to settle in London. After this move Germany was no longer the exclusive piano-making country; England began to compete seriously and soon became the leading center. The most famous among the German makers in London were JACOB KIRCHMANN, who changed his name to KIRCKMAN, and JOHANN CHRISTIAN ZUMPE, a former pupil of Silbermann. [...] The first pianist, too, was a German on English soil—Johann Christian Bach, Johann Sebastian's youngest son, gave the world's first piano recital in 1768 in London.

### 7.2.4 Metronomes

Though technically not a musical instrument, metronomes are an extremely useful tool for musicians. In or before 1814, Dietrich Nikolaus Winkel (Lippstadt, 1777–1826) invented the metronome. Johann Mälzel (German states, 1772–1838) improved and mass-produced metronomes. See Fig. 7.23.



**Gottfried Silbermann**  
**(1683–1753)**

**Christoph Gottlieb**  
**Schröter (1699–1782)**

**Christian Ernst**  
**Friederici (1709–1780)**

**Johann Christoph**  
**Zumpe (1726–1790)**

**Johann Andreas**  
**Stein (1728–1792)**

**Johann Heinrich**  
**Pape (1789–1875)**

### Modern pianos



Figure 7.22: Early pianos evolved from harpsichords and clavichords, but then a series of German-speaking creators made numerous mechanical innovations to develop modern pianos. Some of the major creators included Gottfried Silbermann, Christoph Gottlieb Schröter, Christian Ernst Friederici, Johann Christoph Zumpe, Johann Andreas Stein, and Johann Heinrich Pape.

**Dietrich Nikolaus Winkel (1777–1826)**

**Johann Mälzel (1772–1838)**

### Metronome (1814)



Figure 7.23: Dietrich Nikolaus Winkel invented and Johann Mälzel mass-produced the first metronomes in 1814.

## 7.3 Internal Combustion Engines and Motor Vehicles

In the eighteenth and early nineteenth centuries, most of the major innovations regarding steam engines and vehicles employing them occurred in the United Kingdom and France [Ingo Müller 2007]. Yet when it came time to supersede steam technology with improved engines in the late nineteenth century, it was the more recently developed German-speaking scientific world that rose to the challenge. Indeed, during the late nineteenth and earlier twentieth centuries, engineers from the German-speaking world were responsible for virtually all of the key innovations in the development of internal combustion engines as well as vehicles and tools powered by them, including:<sup>4</sup>

7.3.1. Motorcycles, motorboats, automobiles, and trucks

7.3.2. Chainsaws

7.3.3. Military tanks

7.3.4. Diesel train locomotives

Those German designs were rapidly copied in the United States and other countries, while the German-speaking world soon entered the decades-long period of World Wars I and II and their respective aftermaths, which greatly hindered German and Austrian industries from competing globally in the very technologies that they had pioneered. As a result, most people in the modern world do not realize how directly all of these creations can be traced to German-speaking creators.

### 7.3.1 Internal Combustion Engines, Motorcycles, Motorboats, Automobiles, Trucks

Figure 7.24 shows early steps away from steam engines. ?? Brackenburg (German?, 18??–18??) developed an automobile powered by a hydrogen/oxygen combustion engine in 1836. Julius Hock (Austrian, 18??–19??) developed an oil-burning internal combustion engine in 1873 [Cummins 2002].

With assistance from Eugen Langen (German, 1833–1895), Nikolaus Otto (German, 1832–1891) developed the four-stroke internal-combustion gasoline engine in 1876 [Cummins 2002]. See Fig. 7.25. Gasoline automobile engines still go through the steps known as the Otto cycle. *1001 Inventions That Changed the World* explained the importance of Otto's innovations, as well as his connections to later German engine designers [Challoner 2009, p. 400]:

German engineer Nikolaus Otto (1832–1891) was responsible for one of the great developments in motorized vehicles with the invention of his four-stroke cycle internal combustion engine.

---

<sup>4</sup>For coverage of different aspects of this area, see especially: Cummins 2002; Graf and Metternich 1986; Ludvigsen 2015; Poplow 2011; Raidt 2014; Roth and Schmid 1987; Technisches Museum Wien 2006; Völker 2013.



After developing an interest in technology, he began designs for a four-stroke engine based on Lenoir's earlier design for a two-stroke cycle. In 1864 he set up N. A. Otto and Cie alongside Eugen Langen, creating the world's first engine manufacturers. In 1872, he employed Gottlieb Daimler and Wilhelm Maybach as technical director and chief designer, respectively.

In 1876 the first practical four-stroke engine was constructed. The four strokes are an intake stroke, where the piston moves down to allow a fuel-air mixture into the combustion chamber, a compression stroke, where the piston moves back up to compress the gases, a combustion or power stroke, where a spark ignites the fuel and the piston is forced down again, and a final exhaust stroke, where the piston moves up to expel spent fuel via the exhaust valve. [...]

Initially combustion engines were stationary as they could not be adapted to run on liquid fuel and so required a pilot light. Otto solved this problem in 1884 with the invention of a magneto ignition system that created the spark needed for the power stroke. This increased the practicality of the four-stroke engine and allowed it to be used by Daimler and Maybach in the first motorcycles and automobiles.

As illustrated in Fig. 7.26, Wilhelm Wittig (German?, 18??–19??) and Wilhelm Hees (German?, 18??–19??) developed a two-stroke internal-combustion engine in 1878 [Cummins 2002].

Emile Capitaine (German, 1861–1907) developed an oil-burning internal combustion engine in 1879, a series of gasoline engines in the 1880s–1890s, and a motorcycle in 1896 [Cummins 2002]. See Fig. 7.27.

Rudolf Diesel (German, 1858–1913), shown in Fig. 7.28, created the first Diesel engines in the 1890s [Cummins 2002]. Diesel engines are also internal combustion engines but go through a series of steps somewhat different than the standard Otto cycle. *Encyclopedia Britannica* described the process by which Diesel developed his invention [EB 2010]:

Diesel devoted much of his time to the self-imposed task of developing an internal combustion engine that would approach the theoretical efficiency of the Carnot cycle. For a time he experimented with an expansion engine using ammonia. About 1890, in which year he moved to a new post with the Linde firm in Berlin, he conceived the idea for the diesel engine. He obtained a German development patent in 1892 and the following year published a description of his engine under the title *Theorie und Konstruktion eines rationellen Wärmemotors* (*Theory and Construction of a Rational Heat Motor*). With support from the Maschinenfabrik Augsburg and the Krupp firms, he produced a series of increasingly successful models, culminating in his demonstration in 1897 of a 25-horsepower, four-stroke, single vertical cylinder compression engine. The high efficiency of Diesel's engine, together with its comparative simplicity of design, made it an immediate commercial success, and royalty fees brought great wealth to its inventor.

**?? Brackenburg  
(18??–18??)**

**Automobile powered by a  
hydrogen/oxygen combustion engine (1836)**

**Julius Hock  
(18??–19??)**

**Oil engine (1873)**

Figure 7.24: ?? Brackenburg developed an automobile powered by a hydrogen/oxygen combustion engine in 1836. Julius Hock developed an oil-burning internal combustion engine in 1873.

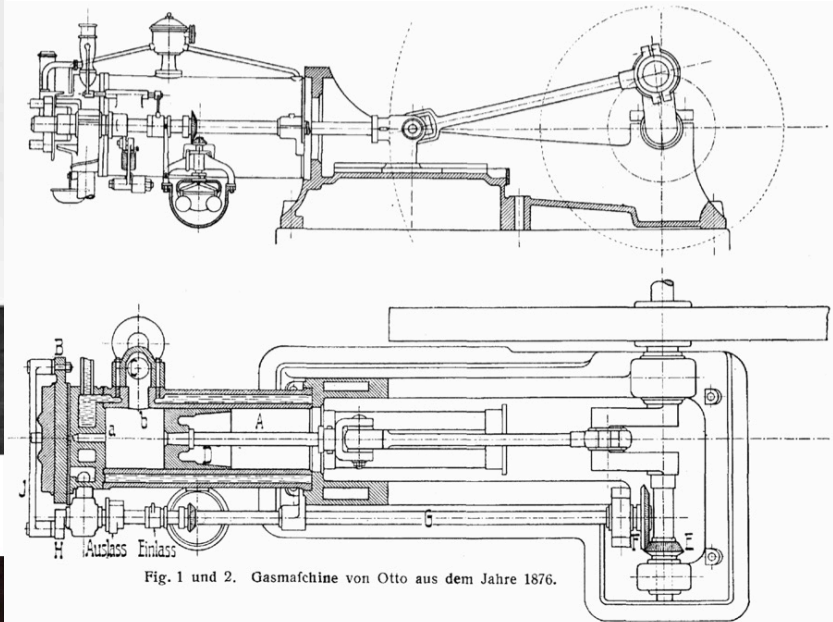
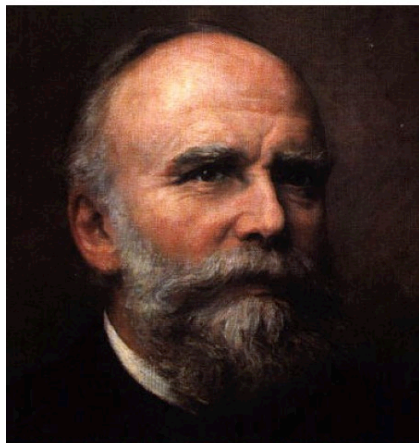
**Nikolaus Otto (1832–1891)****First four-stroke internal-combustion gasoline engine (1876)****Eugen Langen  
(1833–1895)**

Fig. 1 und 2. Gasmachine von Otto aus dem Jahre 1876.

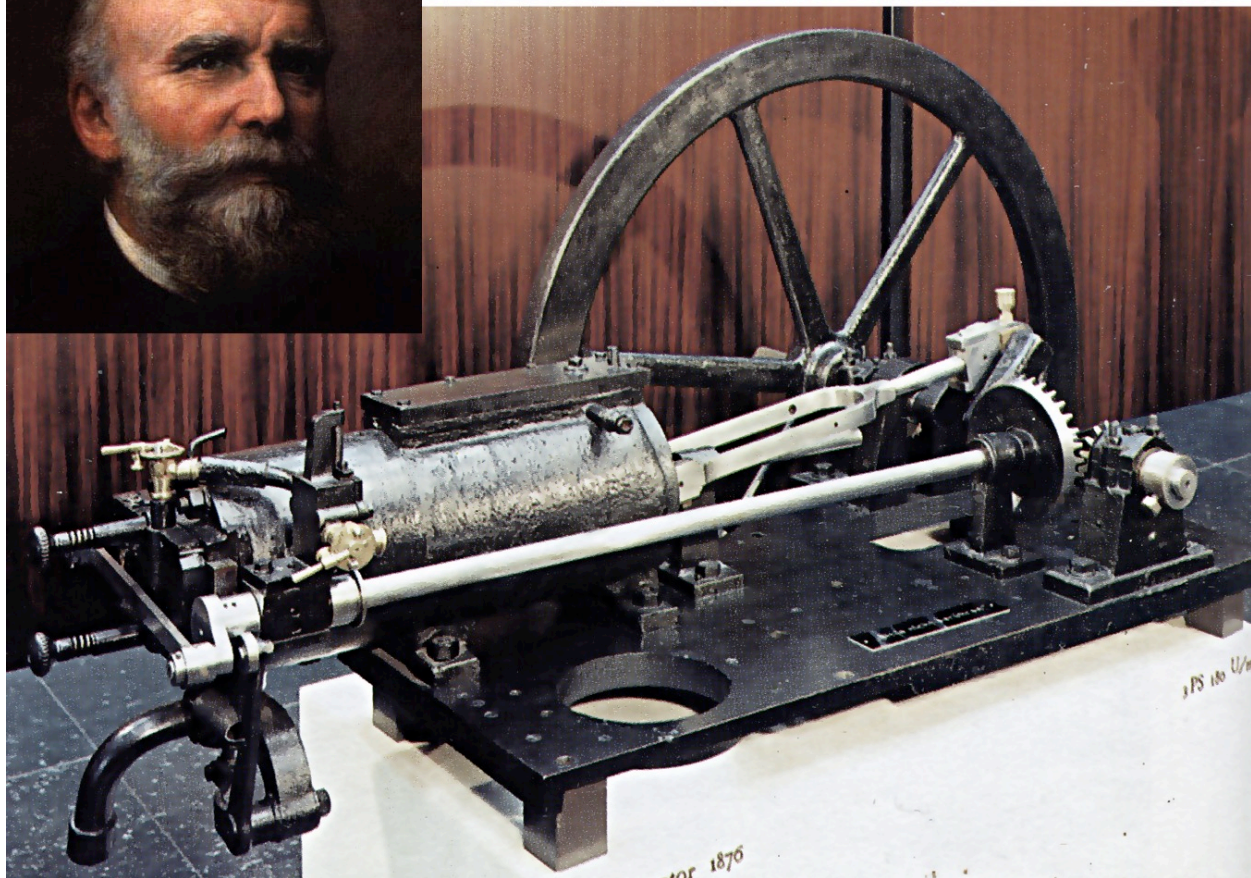


Figure 7.25: With assistance from Eugen Langen, Nikolaus Otto developed the four-stroke internal-combustion gasoline engine in 1876.



Wilhelm Wittig (18??–19??)

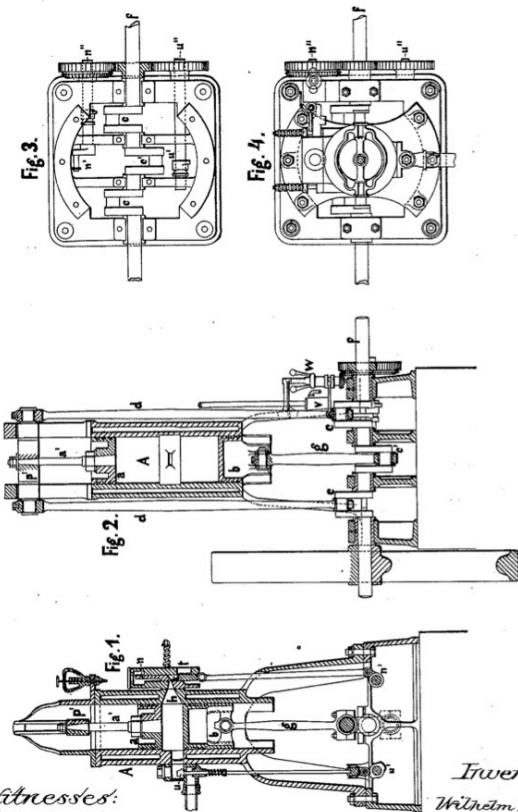
Wilhelm Hees (18??–19??)

### Two-stroke engine (patent application filed 1878)

W. WITTIG & W. HEES.  
Gas-Engine.

No. 213,539.

Patented Mar. 25, 1879.



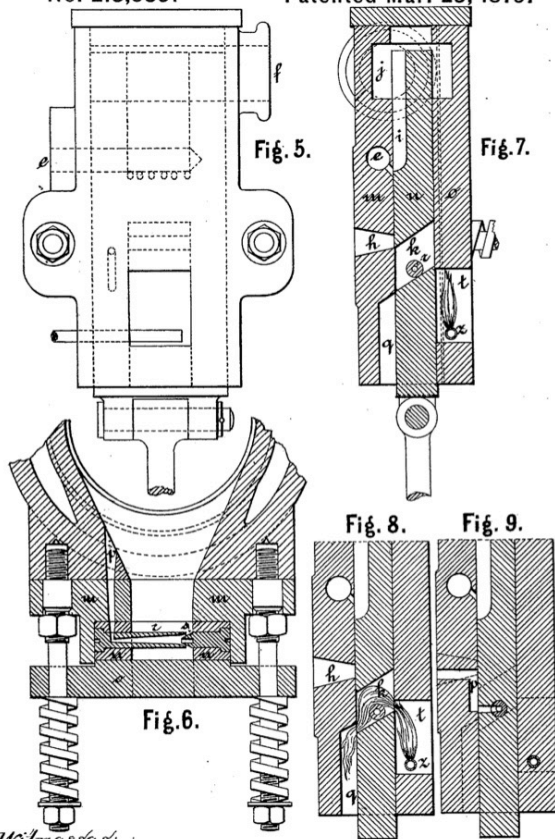
Witnesses:  
W. C. Corlies  
Jno. C. MacGregor.

Inventors  
Wilhelm Wittig  
Wilhelm Hees  
By: Coburn Thacher  
Attorneys.

W. WITTIG & W. HEES.  
Gas-Engine.

No. 213,539.

Patented Mar. 25, 1879.



Witnesses:  
W. C. Corlies  
Jno. C. MacGregor.

Inventors  
Wilhelm Wittig  
Wilhelm Hees  
Coburn Thacher Atty's.

Figure 7.26: Wilhelm Wittig and Wilhelm Hees developed a two-stroke internal-combustion engine in 1878.

**Emile Capitaine (1861–1907)**

(No Model.)

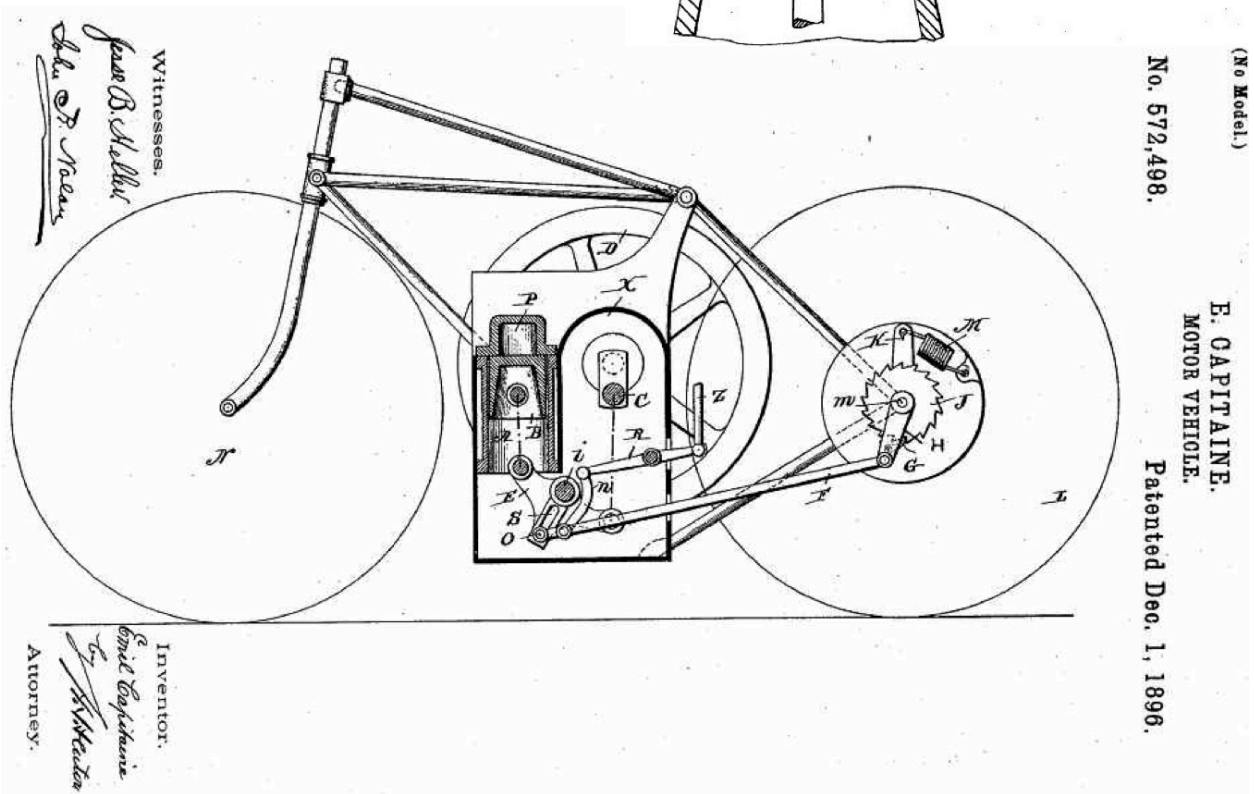
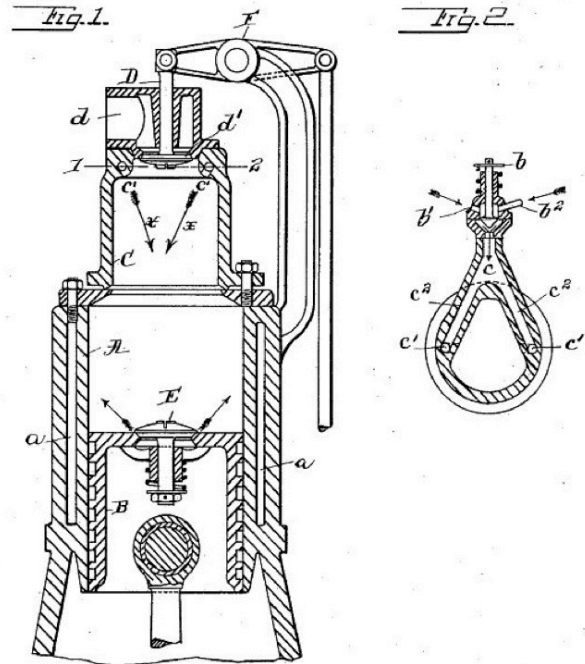
E. CAPITAINE.

VAPORIZER AND COMBUSTION CHAMBER FOR PETROLEUM MOTORS.

No. 581,412.

Patented Apr. 27, 1897.

- Oil engine (1879)
- Gasoline engines (1880s–1890s)
- Motorcycle (1896)



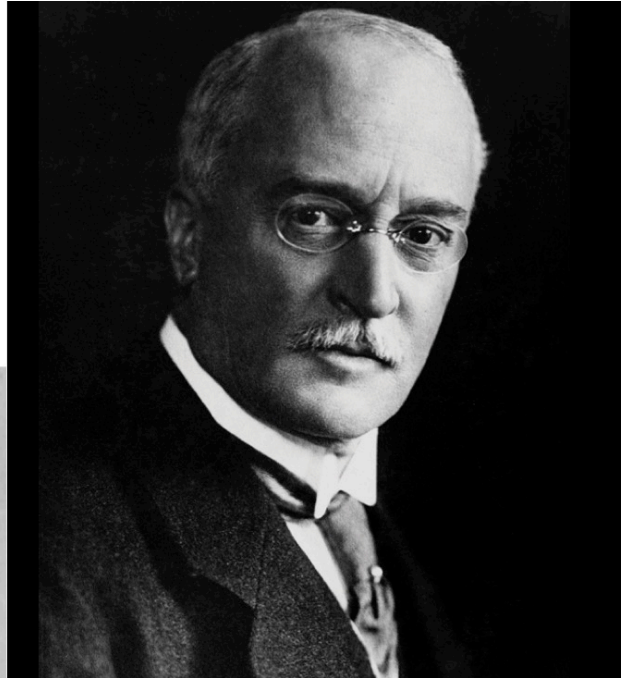
(No Model.)  
No. 572,498.

E. CAPITAINE.  
MOTOR VEHICLE.

Patented Dec. 1, 1896.

Figure 7.27: Emile Capitaine developed an oil-burning internal combustion engine in 1879, a series of gasoline engines in the 1880s–1890s, and a motorcycle in 1896.

**Rudolf Diesel  
(1858–1913)**



**Diesel engine (1893)**

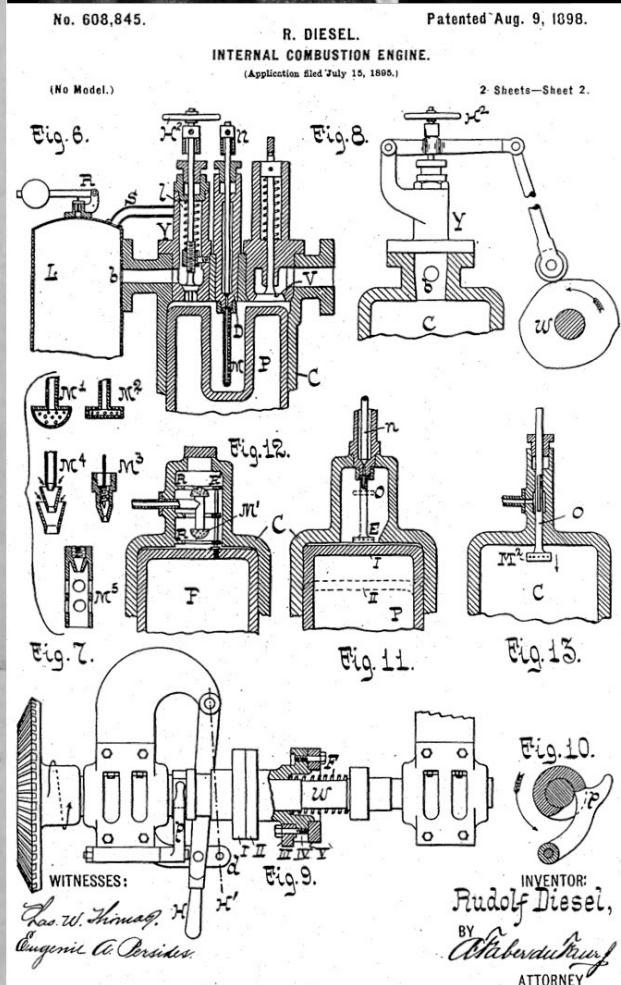
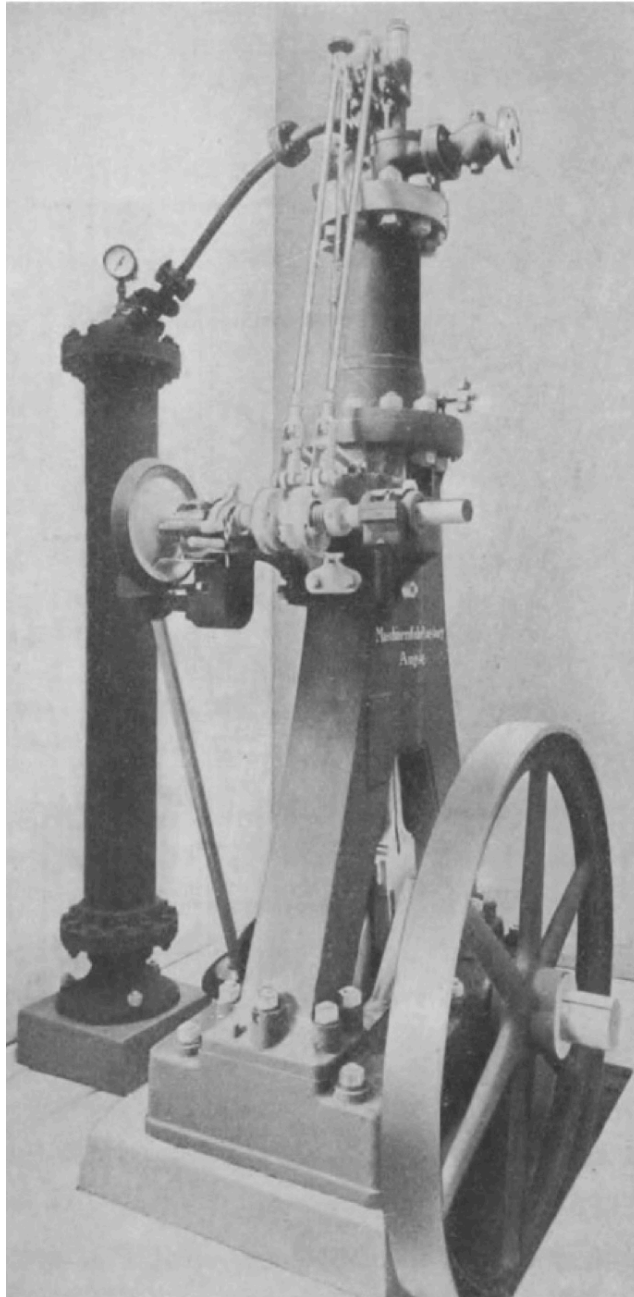


Figure 7.28: Rudolf Diesel created the first Diesel engine in 1893.



Siegfried Marcus (German/Austrian, 1831–1898) developed an internal-combustion-engine-powered car in 1870, and then a greatly improved version in 1888 [Technisches Museum Wien 2006]. Figure 7.29 presents photos of Marcus and his two car versions.

As shown in Fig. 7.30, Karl Benz (German, 1844–1929) and his wife Bertha Benz (German, 1849–1944) developed and demonstrated an internal-combustion-engine-powered automobile in 1885 [Cummins 2002]. *1001 Inventions That Changed the World* explained how they publicized their first automobile [Challoner 2009, p. 446]:

Benz recognized the great potential of petrol as a fuel. His three-wheeled car had a top speed of just ten miles (16 km) per hour with its four-stroke, one-cylinder engine. After receiving his patent in January 1886, he began selling the Benz [...], but the public doubted its reliability. Benz’s wife Bertha had a brilliant idea to advertise the new car. In 1888 she took it on a 60-mile (100 km) trip from Mannheim to near Stuttgart.

Benz developed other automobiles such as the first mass-produced automobile (Velo) in 1894, the first internal-combustion-engine-powered bus (Omnibus) in 1895, and a record-setting race car (Blitzen) in 1909 [Grünewald and Williamson 2013; Roth and Schmid 1987]. See Fig. 7.31.

Gottlieb Daimler (German, 1834–1900) and Wilhelm Maybach (German, 1846–1929), shown in Fig. 7.32, initially worked for Nikolaus Otto but then started their own company. They created the first internal-combustion-powered motorcycle (Reitwagen) in 1885 and their first internal-combustion-powered automobile (Motorcoach) in 1886 [Cummins 2002; Raidt 2014; Völker 2013]. Daimler and Maybach also created the first internal-combustion-powered boat in 1886 and the first internal-combustion-powered truck in 1896; see Fig. 7.33. Oxford University’s *Biographical Dictionary of Scientists* described the key to their success [Porter 1994, p. 159]:

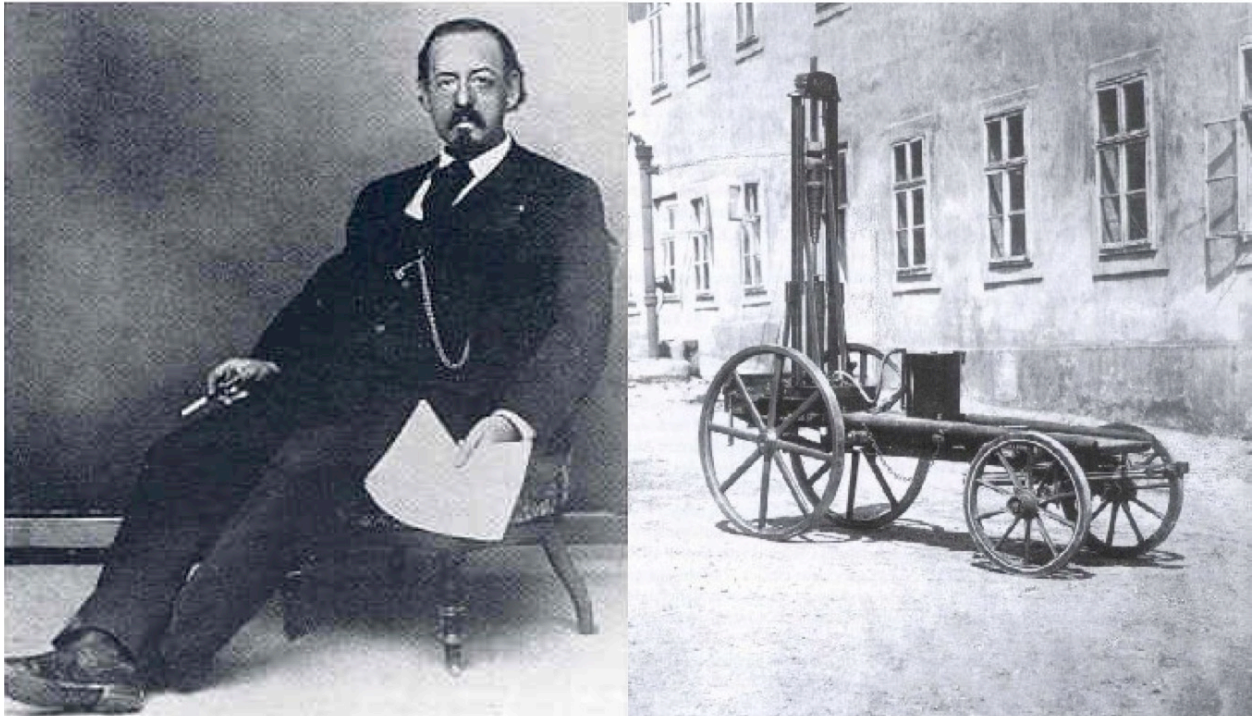
The genius of Daimler and Maybach lay in the combining of four of the elements essential to the modern car engine: the four-stroke Otto cycle, the vaporization of the fuel with a device similar to a carburettor, low weight and high speeds. Lenoir had used electric ignition, but this proved unreliable; Daimler and Maybach used an igniter tube that was light, worked well and operated independently of engine speed.

As illustrated in Figs. 7.34–7.36, in 1900, Wilhelm Maybach, Paul Daimler (German, 1869–1945), and Emil Jellinek (German/Austrian, 1853–1918) radically rethought the look of “horseless carriages” and developed the first automobile with a recognizably modern design, the Mercedes 35 hp. This was the first of a long line of automobiles that were named after Jellinek’s daughter, Mercédès Jellinek (Austrian, 1889–1929) [Roth and Schmid 1987]. In the United States, Henry Ford’s first Model T automobile, produced in 1909, was essentially a carbon copy of that 1900 German design. Soon thereafter, the German-speaking world was plunged into decades of war and the aftermath, giving great advantage to such foreign-made copies in the global market.

Robert Bosch (German, 1861–1942) created a magnetic engine ignition system and spark plugs in 1887 [Raidt 2014]. He was later joined by Gottlob Honold (German, 1876–1923), with whom he developed improved automobile engines, the car horn, and automotive headlights. See Fig. 7.37.

**Siegfried Marcus (1831–1898)**

**First Marcus car (1870)**



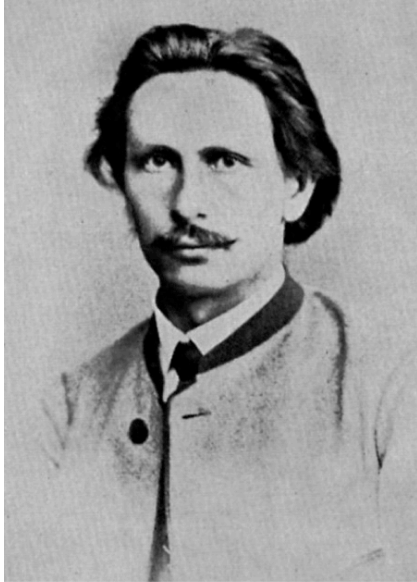
**Second Marcus car (1888)**



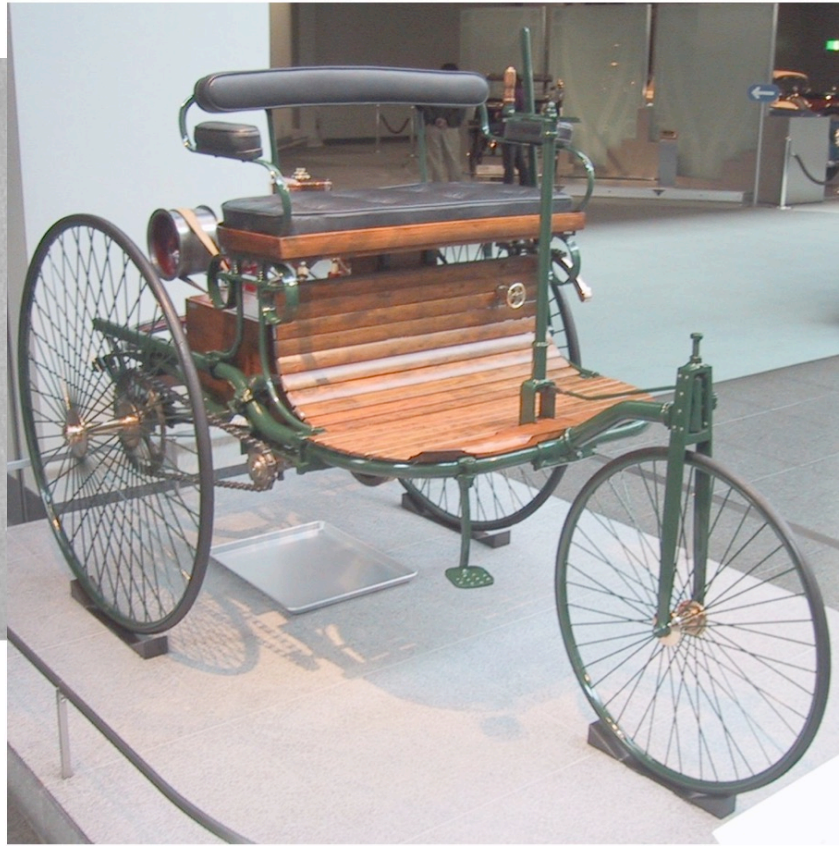
Figure 7.29: Siegfried Marcus developed an internal-combustion-engine-powered car in 1870, and a greatly improved version in 1888.



**Karl Benz  
(1844–1929)**



**Benz Patent Motorwagen (1885)**



**Bertha Benz  
(1849–1944)**



**Benz Patent Motorwagen engine**

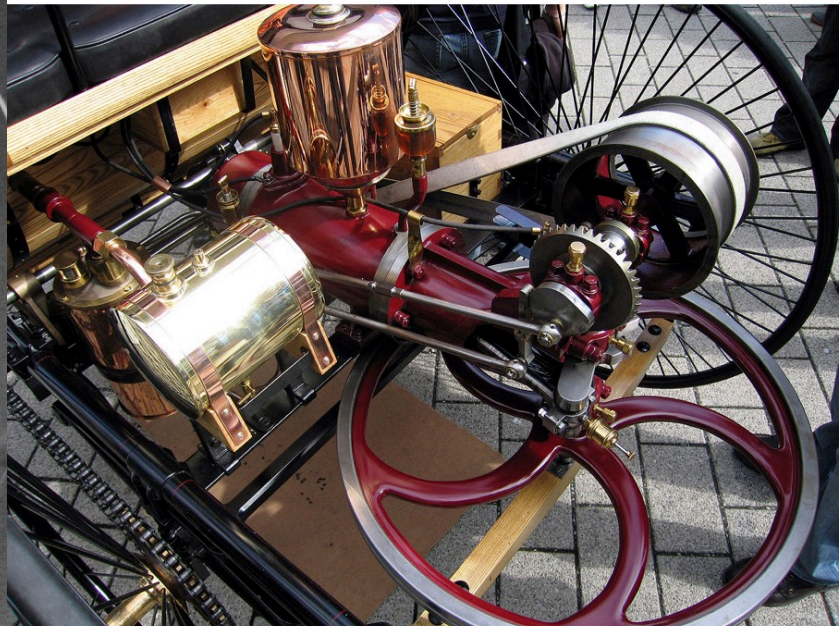


Figure 7.30: Karl Benz and his wife Bertha Benz developed and demonstrated an internal-combustion-engine-powered automobile in 1885.



**Benz Velo**  
first mass-produced  
automobile (1894)



**Benz Omnibus**  
first internal-combustion  
engine-powered bus (1895)



**Blitzen Benz (1909)**  
land speed record:  
227 km/hr (142 mi/hr)

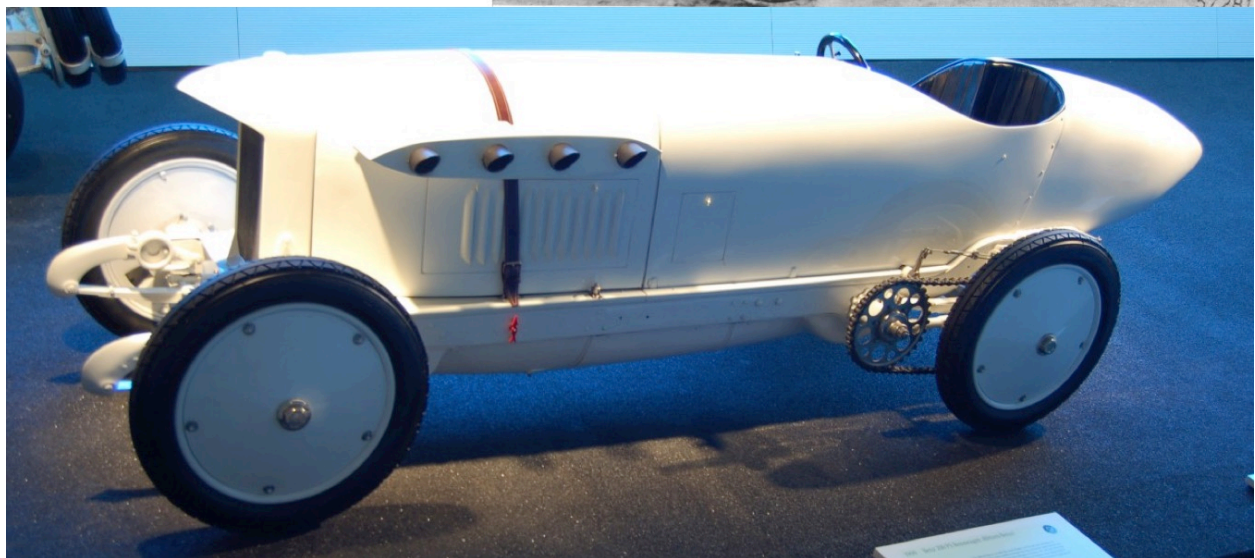


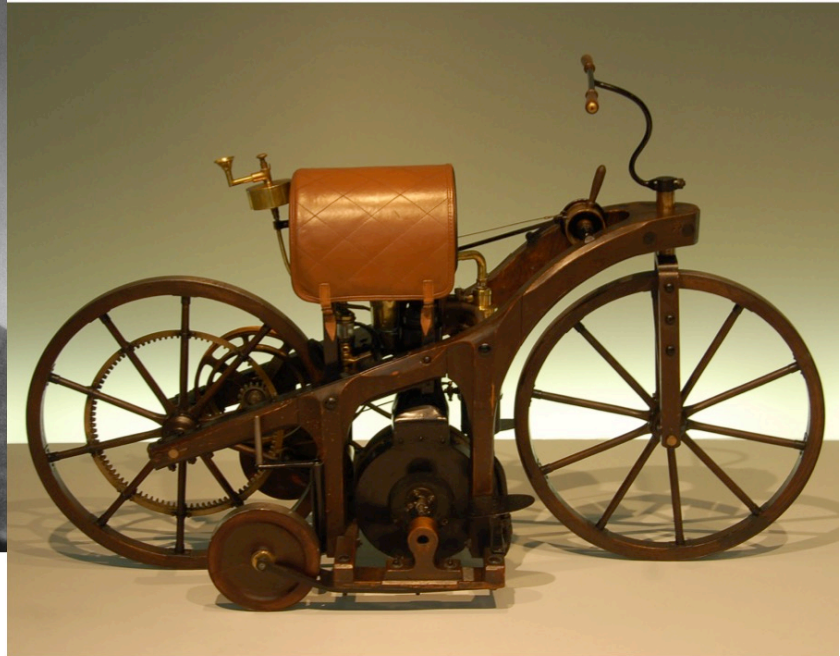
Figure 7.31: Benz developed other automobiles such as the first mass-produced automobile (Velo) in 1894, the first internal-combustion-engine-powered bus (Omnibus) in 1895, and a record-setting race car (Blitzen) in 1909.



**Gottlieb Daimler  
(1834–1900)**



**Daimler-Maybach Reitwagen  
first internal-combustion-  
powered motorcycle (1885)**



**Daimler-Maybach Motorcoach  
internal-combustion-powered  
automobile (1886)**

**Wilhelm Maybach  
(1846–1929)**

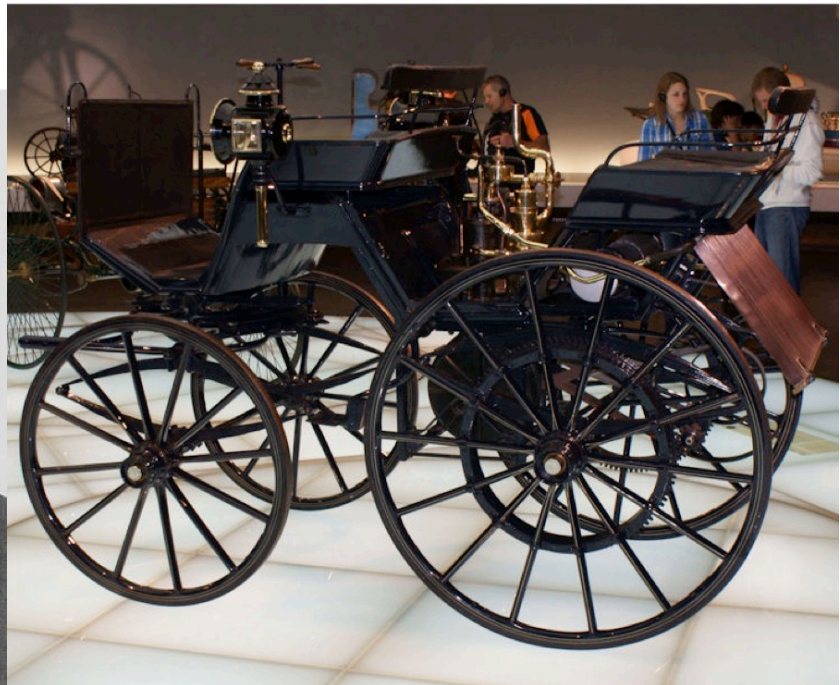


Figure 7.32: Gottlieb Daimler and Wilhelm Maybach created the first internal-combustion-powered motorcycle (Reitwagen) in 1885, and their first internal-combustion-powered automobile (Motorcoach) in 1886.



**Daimler-Maybach Neckar  
first motorboat (1886)**



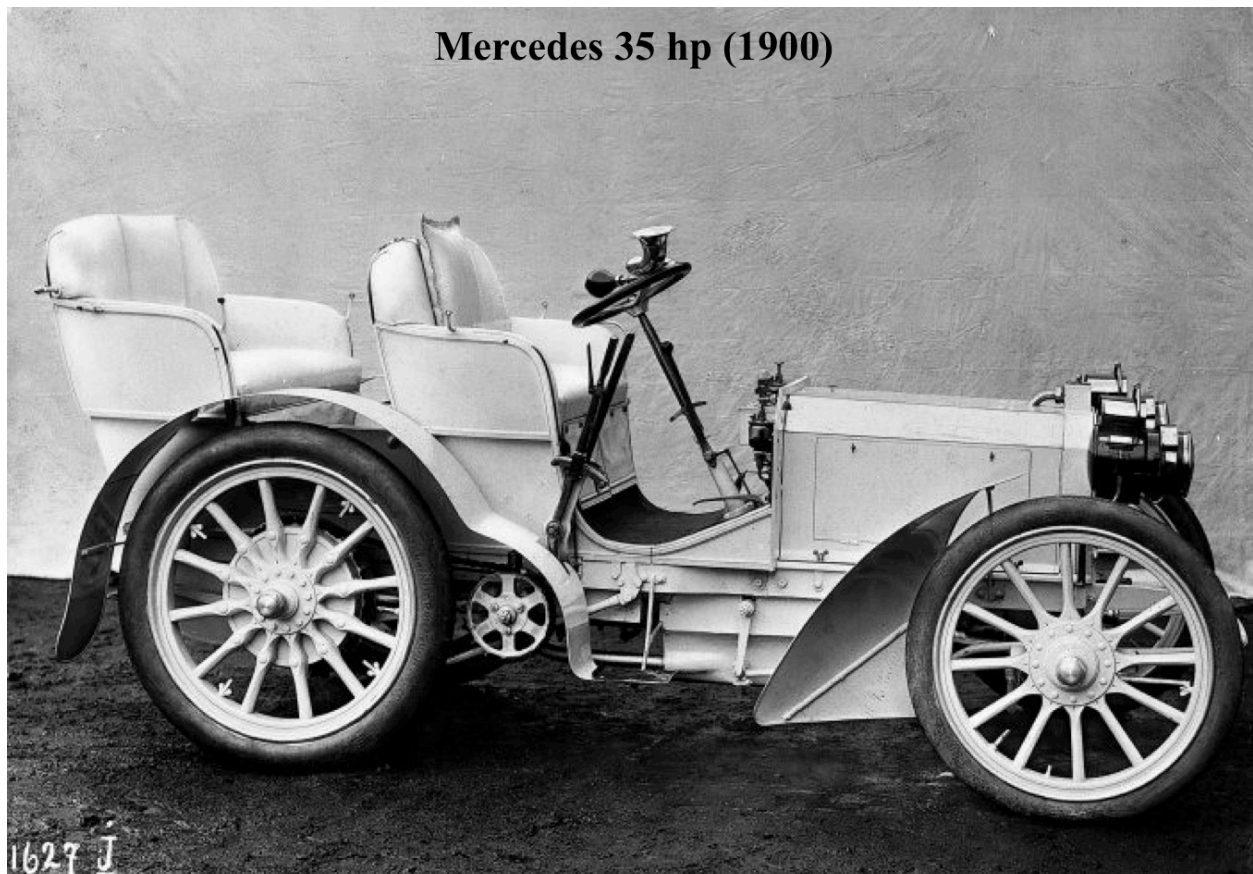
**Daimler-Maybach Lastwagen  
first internal-combustion-  
powered truck (1896)**

Figure 7.33: Gottlieb Daimler and Wilhelm Maybach created the first internal-combustion-powered boat in 1886 and truck in 1896.



**Mercedes automobiles****Wilhelm Maybach (1846–1929)****Paul Daimler (1869–1945)****Emil Jellinek (1853–1918)****Mercédès Jellinek (1889–1929)**

Figure 7.34: In 1900, Wilhelm Maybach, Paul Daimler, and Emil Jellinek developed a radically redesigned automobile with a recognizably modern look, the Mercedes 35 hp. It was named after Emil Jellinek's daughter, Mercédès Jellinek, and was the first of a long line of Mercedes automobiles.



**Henry Ford's first Model T automobile (United States, 1909)**

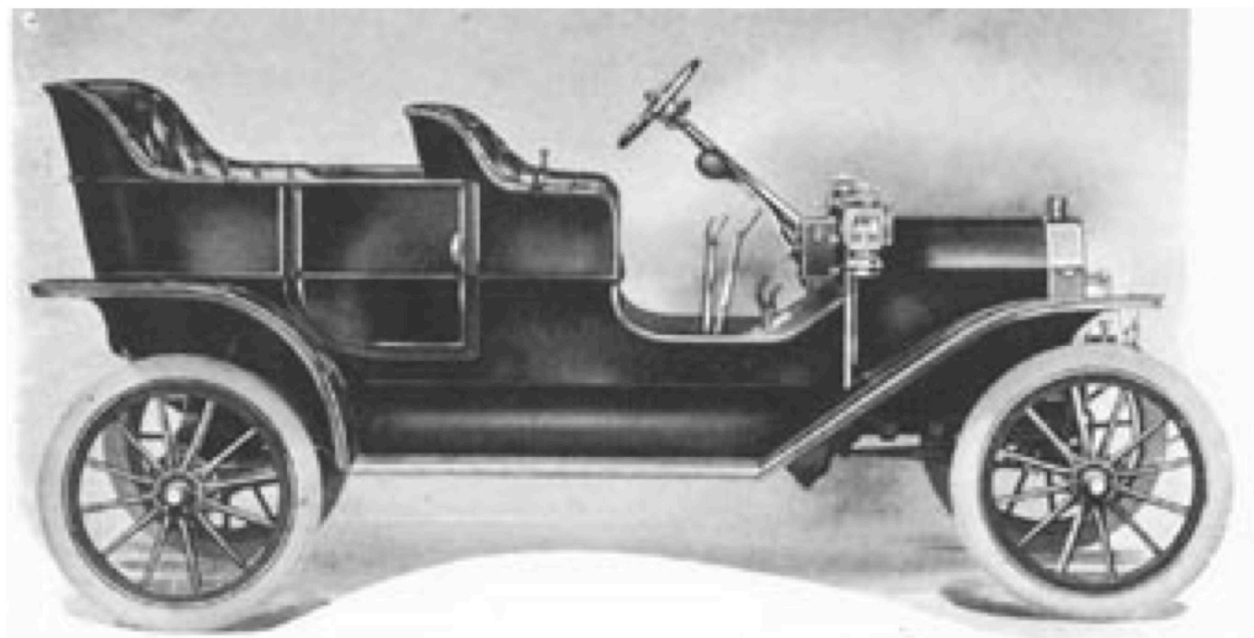


Figure 7.35: Wilhelm Maybach, Paul Daimler, and Emil Jellinek developed the first automobile with a recognizably modern design, the Mercedes 35 hp, in 1900. In the United States, Henry Ford's first Model T automobile, produced in 1909, was essentially a carbon copy of that earlier German design.

**Mercedes 15/70/100 PS (1924)  
(later named Mercedes-Benz Type 400)**

**Designed by Wilhelm Maybach and Ferdinand Porsche**

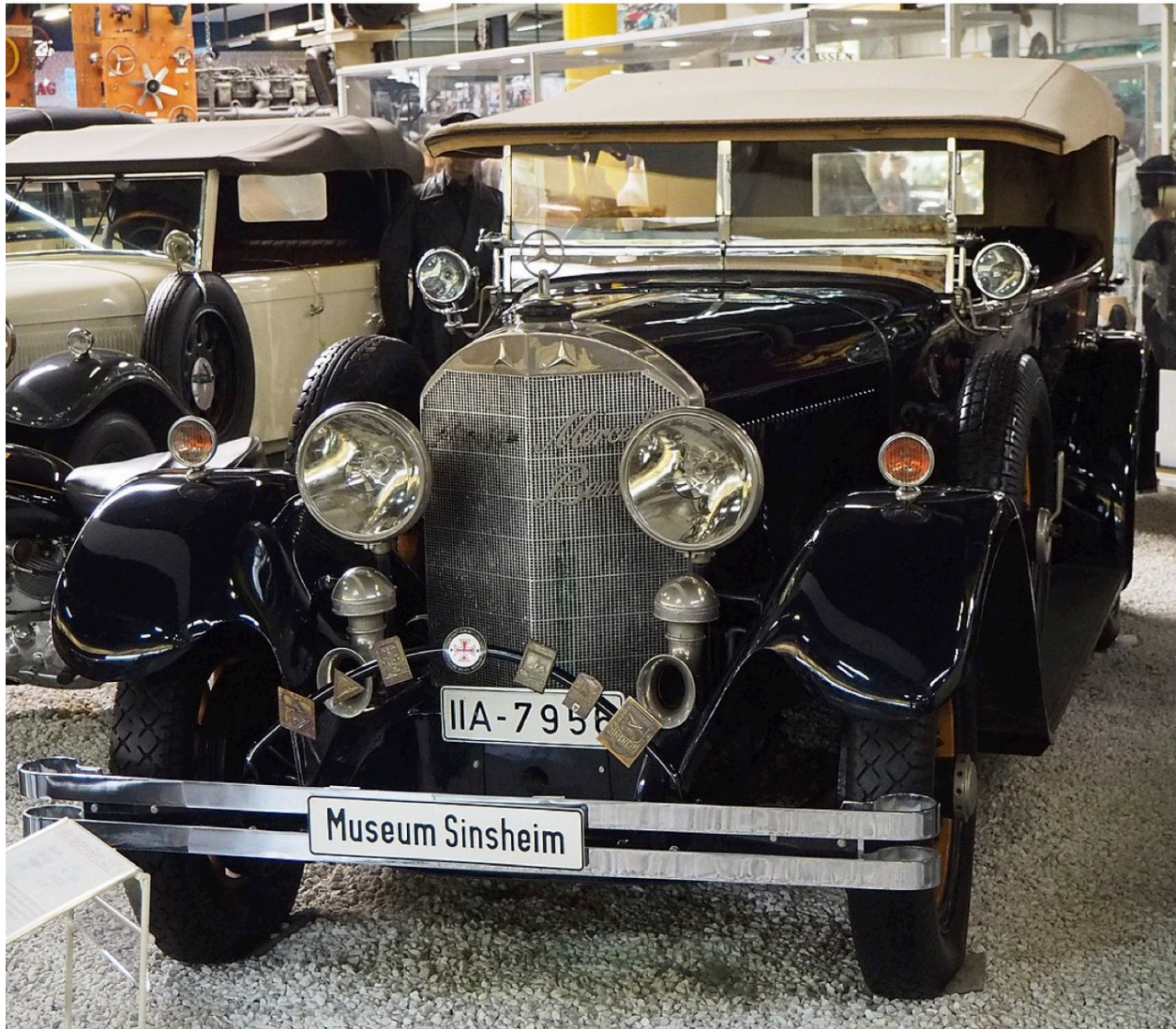
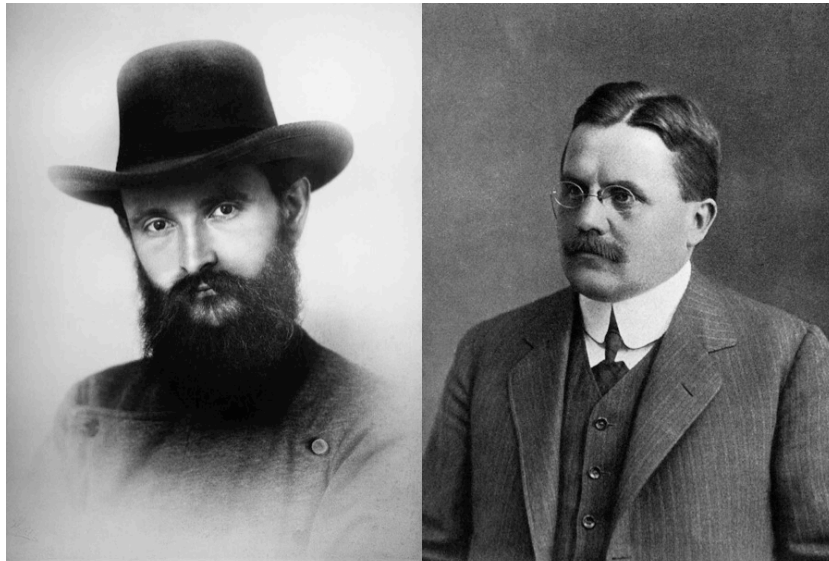


Figure 7.36: Wilhelm Maybach and Ferdinand Porsche designed the Mercedes 15/70/100 PS (1924, later named Mercedes-Benz Type 400).

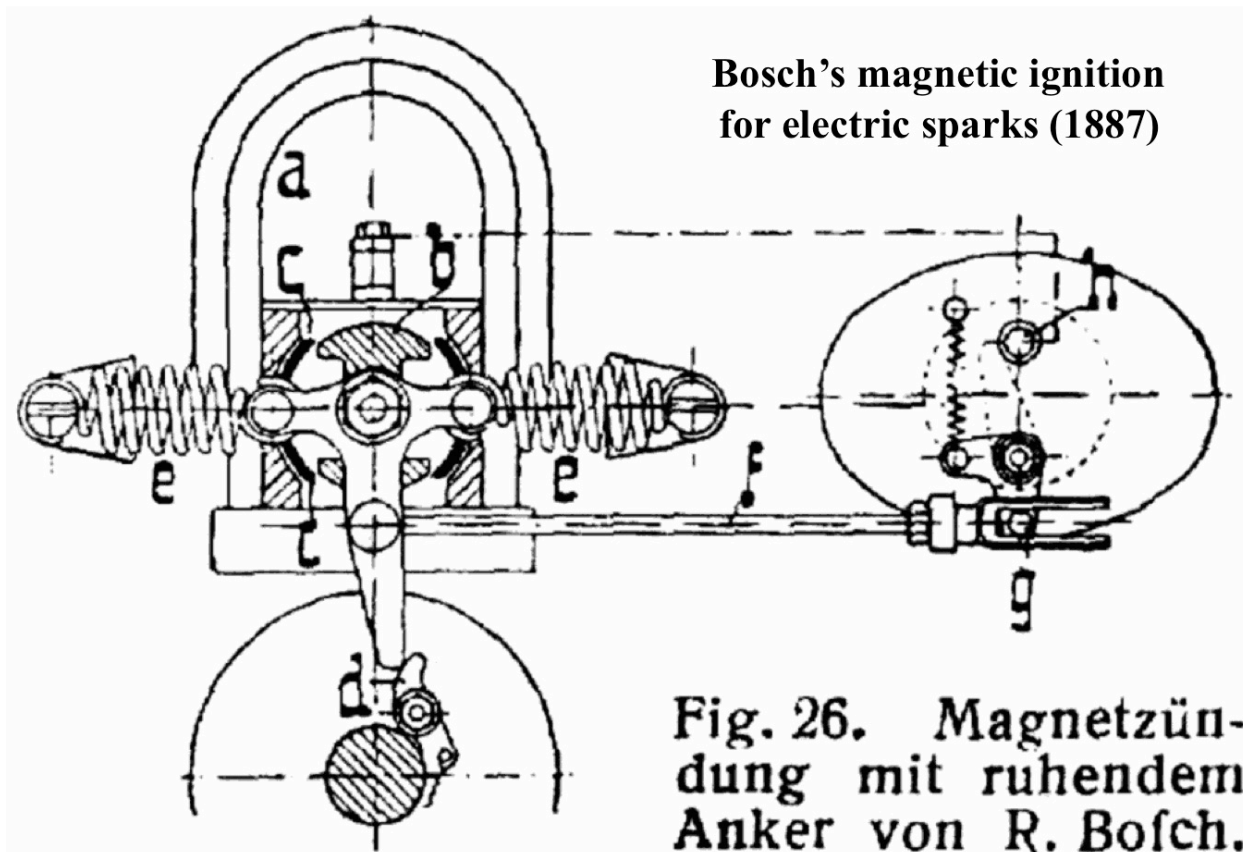


**Robert Bosch**  
(1861–1942)

**Gottlob Honold**  
(1876–1923)



- Improved engines
- Spark plugs
- Car horn
- Headlights



**Bosch's magnetic ignition  
for electric sparks (1887)**

**Fig. 26. Magnetzündung mit ruhendem Anker von R. Bosch.**

Figure 7.37: Robert Bosch created a magnetic engine ignition system and spark plugs in 1887. He was later joined by Gottlob Honold, with whom he developed improved automobile engines, the car horn, and automotive headlights.

Figure 7.38 presents several other automotive creators:

- Paul Winand (German?, 18??–19??) also developed spark plugs in 1887 [Cummins 2002].
- Donát Bánki (Hungarian, 1859–1922) and János Csonka (Hungarian, 1852–1939) produced an improved carburetor.
- Hugo Mayer (German?, 18??–19??) created hydraulic auto brakes.
- Wilhelm von Opel (German, 1871–1948) introduced assembly line production of automobiles in Europe.
- Ludwig Elsbett (German, 1913–2003) developed improved diesel engines, as well as engines that run on vegetable oil as biofuel [www.elsbett-museum.de].

As shown in Fig. 7.39, Edmund Rumpler (Austrian, 1872–1940) not only was the first aircraft manufacturer in Germany, but also designed aerodynamic automobiles (such as the 1923 Rumpler-Benz Tropfenwagen), created a unified engine and gearbox, and developed swing-axle rear suspension [Graf and Metternich 1986].

Ferdinand Porsche (Austrian/German, 1875–1951) created the first gasoline-electric hybrid automobile (Lohner-Porsche) in 1900; see Fig. 7.40. In fact, development, production, and use of electric vehicles continued to be emphasized in the German-speaking world through 1945. For example, BIOS 384, *German Battery Electric Vehicles and the German Storage Battery Industry*, p. 28, reported:

The GERMANS make very much more use of battery electric vehicles of all forms than is the custom in BRITAIN. They also employ batteries, both lead-acid and nickel-iron for a greater range of uses.

As shown in Fig. 7.36, Porsche also did early design work at Daimler, such as for the 1924 Mercedes 15/70/100 PS and its successors (later named the Mercedes-Benz Type 400).

For his later projects, Porsche was joined by Karl Rabe (Austrian, 1895–1968). Porsche, Rabe, and their team developed the prototype for what would become the Volkswagen Beetle (1931, Fig. 7.41), as well as a series of Auto Union racing cars in the 1930s [Christopher 2013, pp. 199–203; Ludvigsen 2015].

**Paul Winand**  
(18??–19??)  
spark plugs (1887)

**Donát Bánki**  
(1859–1922)

improved carburetor (1893)

**János Csonka**  
(1852–1939)



**Hugo Mayer**  
(18??–19??)  
hydraulic auto  
brakes (1895)

**Wilhelm von Opel**  
(1871–1948)  
assembly line  
production of  
automobiles

**Ludwig Elsbett**  
(1913–2003)  
improved diesel engines,  
engines that run on  
vegetable oil biofuel



Figure 7.38: Paul Winand also developed spark plugs in 1887. Donát Bánki and János Csonka produced an improved carburetor, Hugo Mayer created hydraulic auto brakes, and Wilhelm von Opel introduced assembly line production of automobiles in Europe. Ludwig Elsbett developed improved diesel engines, as well as engines that run on vegetable oil as biofuel.



**Edmund Rumpler (1872–1940)**

- **First German aircraft manufacturer**
- **Aerodynamic automobiles**
- **Unified engine/gearbox**
- **Swing-axle rear suspension**

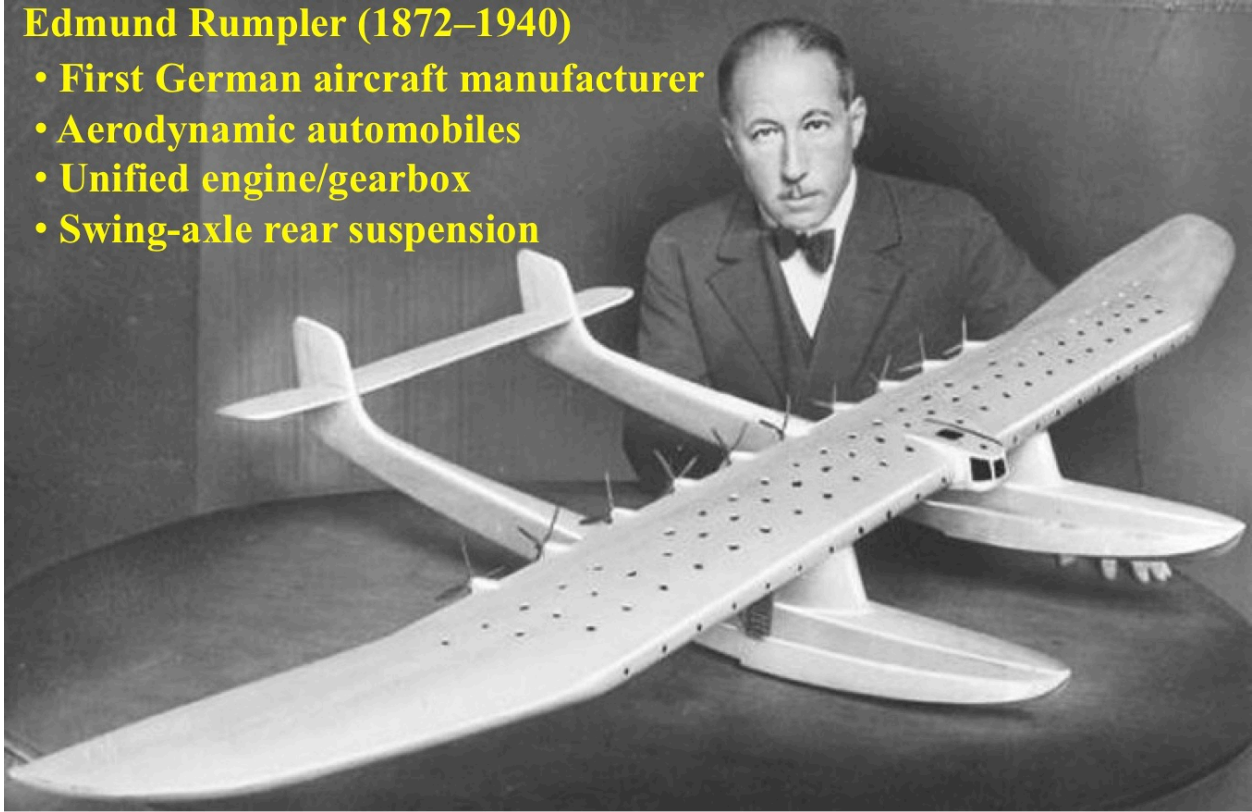
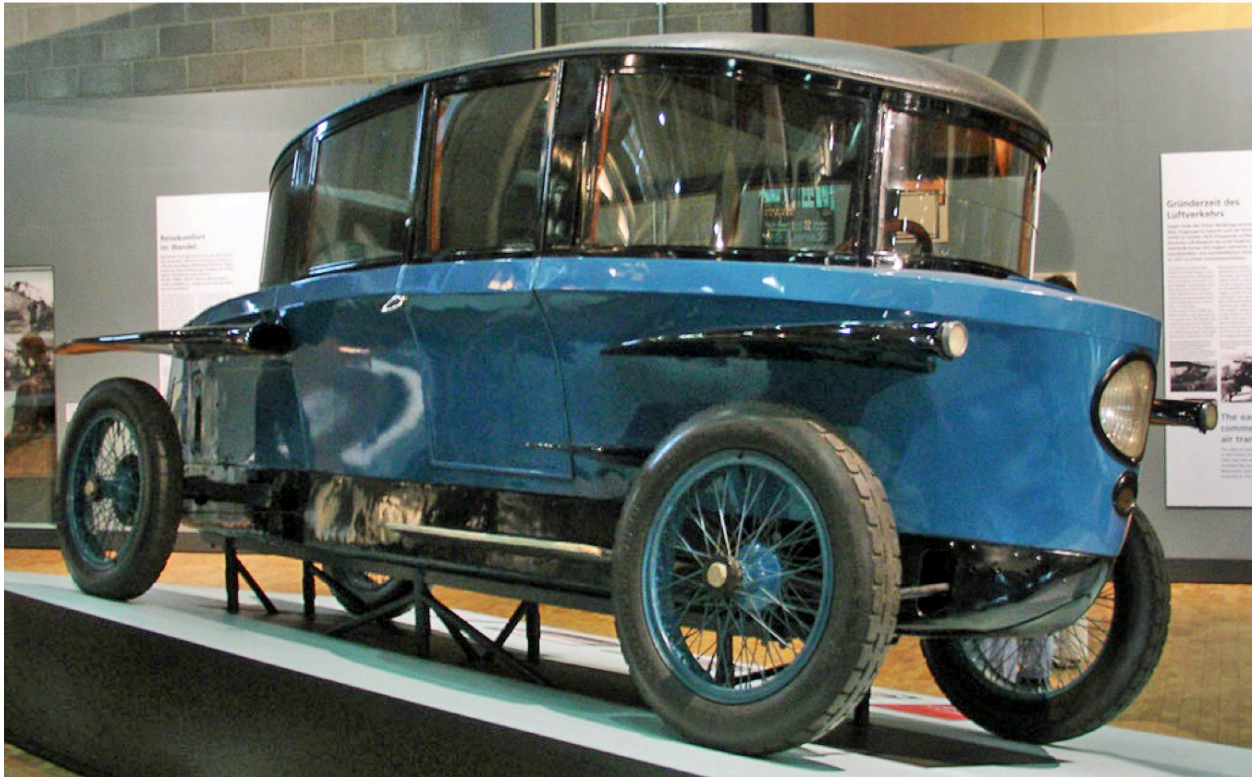
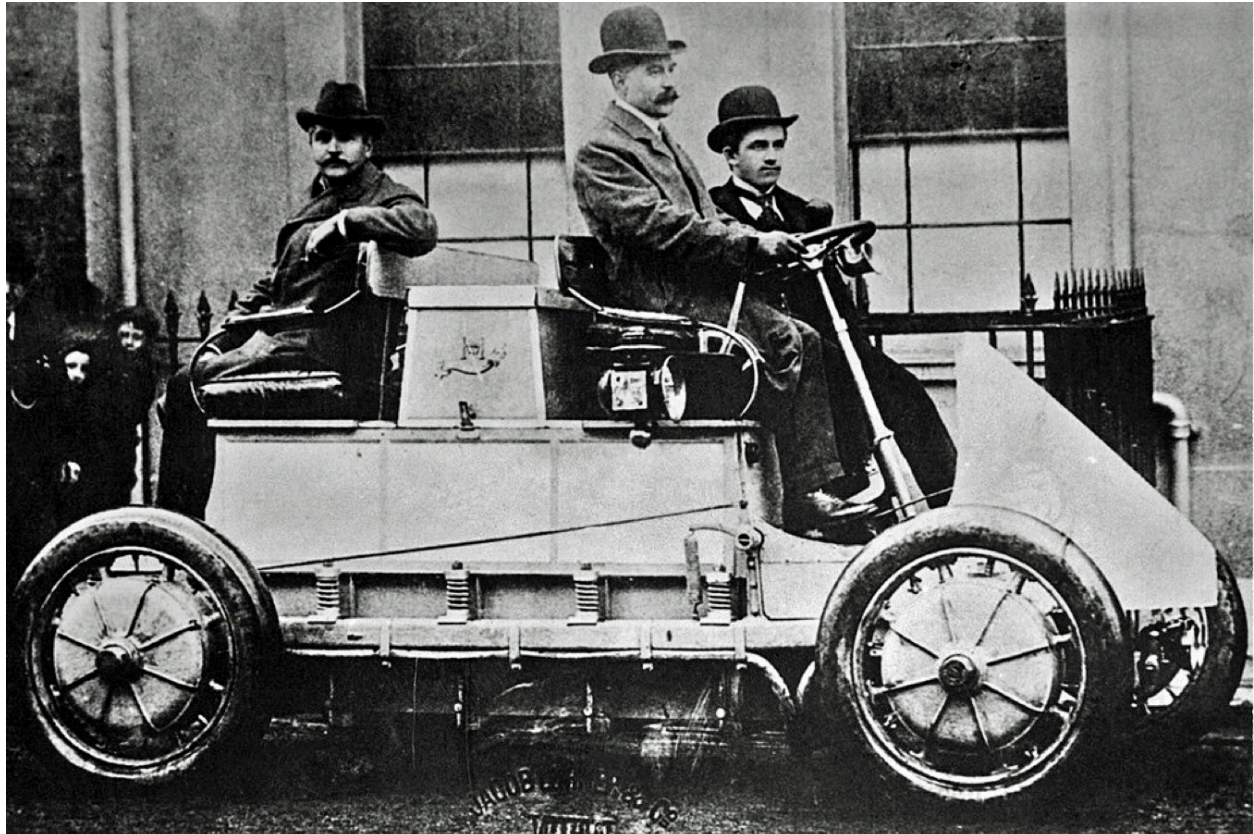
**Rumpler-Benz Tropfenwagen (1923)**

Figure 7.39: Edmund Rumpler was the first German aircraft manufacturer, designed aerodynamic automobiles (such as the 1923 Rumpler-Benz Tropfenwagen), created a unified engine and gearbox, and developed swing-axle rear suspension.





**Lohner-Porsche  
first gasoline-electric  
hybrid automobile  
(1900)**



**Ferdinand Porsche  
(left,  
1875–1951)**

**Karl Rabe  
(right,  
1895–1968)**

Figure 7.40: Ferdinand Porsche created the first gasoline-electric hybrid automobile (Lohner-Porsche) in 1900. For his subsequent projects, Porsche was joined by Karl Rabe.



### **Porsche prototype for what would become the Volkswagen Beetle (1931)**



### **Porsche Auto Union racing cars (1933–1939)**



Figure 7.41: Ferdinand Porsche, Karl Rabe, and their team developed the prototype for what would become the Volkswagen Beetle (1931), as well as a series of Auto Union racing cars in the 1930s.



Oxford University's *Biographical Dictionary of Scientists* described some of Porsche's innovations [Porter 1994, pp. 560–561]:

In 1936, he received a contract from the German government to develop the Volkswagen and plan the factory where it would be built. Just before this he conceived a racing car, without contract. The project was taken over by Auto Union and the car subsequently claimed victories on virtually every race track in Europe between 1934 and 1937, as well as many class records.

The first VW prototypes were on the road by the end of 1935[...] Some other design jobs, however, had appeared alongside the major Volkswagen contract to cause Porsche to expand his company. [...]He led the development of light tractors. Those tractors built to Porsche licence and under the firm's supervision after World War II can be traced to these designs. Concepts were also developed by him for aviation engines as well as plans and designs of wind-driven power plants—large wind-mills with automatic sail adjustment which delivered electric current via generators.

The war cut short further development of the Volkswagen so Porsche designed the Leopard and Tiger tanks used by German Panzer regiments and helped to develop the V-1 flying bomb. [...]

Porsche was a brilliant engineer whose genius reached into many disciplines. It has been said that the torsion-bar suspension alone would have sufficed to establish a monument to his name in the automotive industry. He can be considered one of the pioneers of aircooled engines in the industry.

Karl Schlör (German, 1911–1997), shown in Fig. 7.42, designed the Schlörwagen highly aerodynamic automobile in 1936 and demonstrated it in 1939 [Christopher 2013, pp. 199–201]. Even on today's roads, the Schlörwagen would look very forward-thinking.

German-speaking engineers not only took automobiles every step of the way from their first invention to high-speed aerodynamic models; they also carried motorcycles from their first creation (p. 1344) to sleek racing models. For example, when fitted with an aerodynamic shell, the BMW 500 Kompressor motorcycle model held the worldwide speed record for motorcycles from 1935 to 1951 (Fig. 7.43). It had a top speed of 279.5 km/hr in 1937.

As illustrated in Fig. 7.44, Felix Wankel (German, 1902–1988) developed Wankel rotary engines from 1924 onward. Hanns Paschke (German, 19??–??) later developed additional versions of Wankel engines [Popplow 2011]. Due to their very compact size, Wankel engines have been used in motorcycles, small cars, and small aircraft.

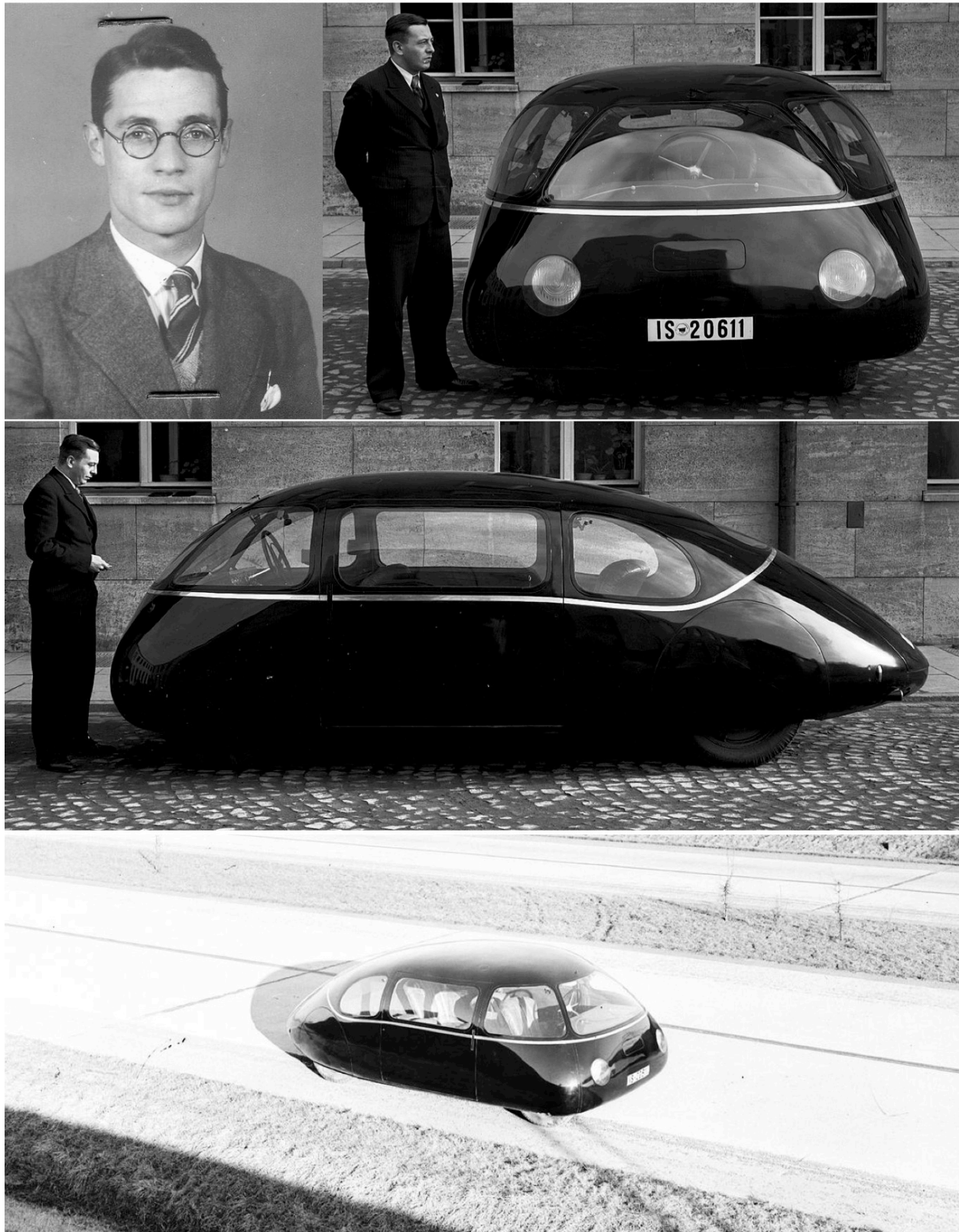
**Karl Schlör (1911–1997) Schlörwagen aerodynamic auto (1939)**

Figure 7.42: Karl Schlör developed and demonstrated the Schlörwagen highly aerodynamic automobile in 1939.



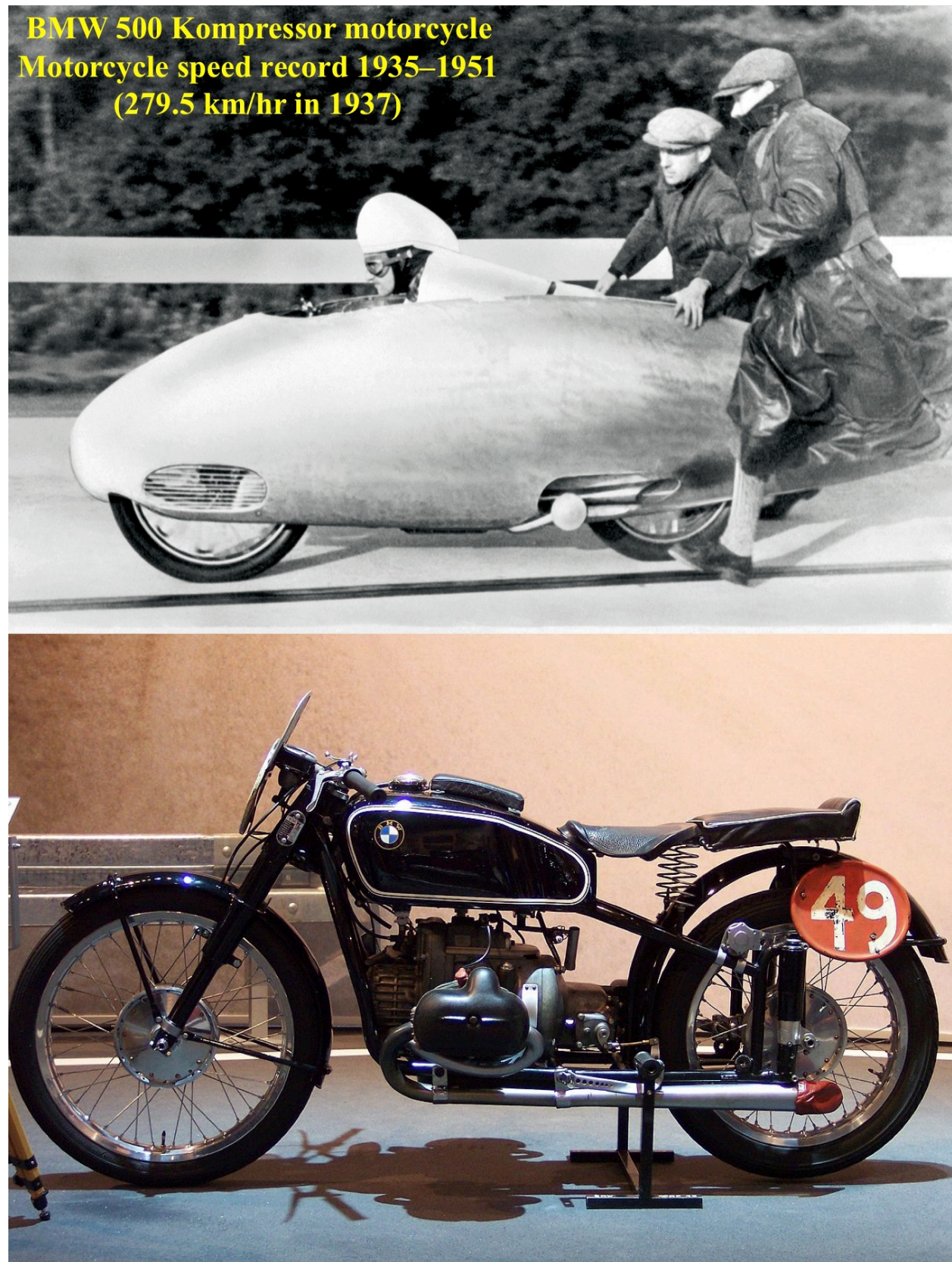
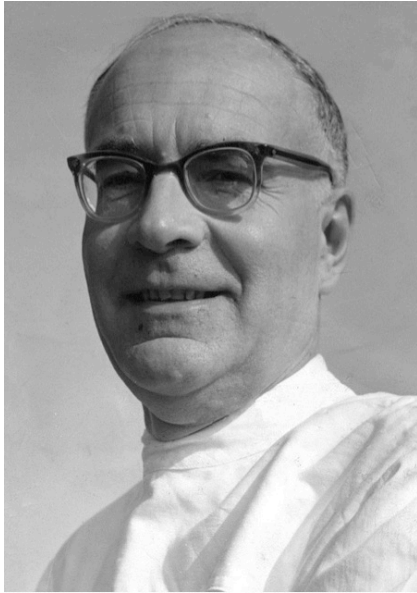


Figure 7.43: The BMW 500 Kompressor motorcycle model (enclosed in an aerodynamic shell above, and without the shell below) held the worldwide speed record for motorcycles from 1935 to 1951. It had a top speed of 279.5 km/hr in 1937.





**Felix Wankel**  
**(1902–1988)**

**Hanns Paschke**  
**(19??–19??)**

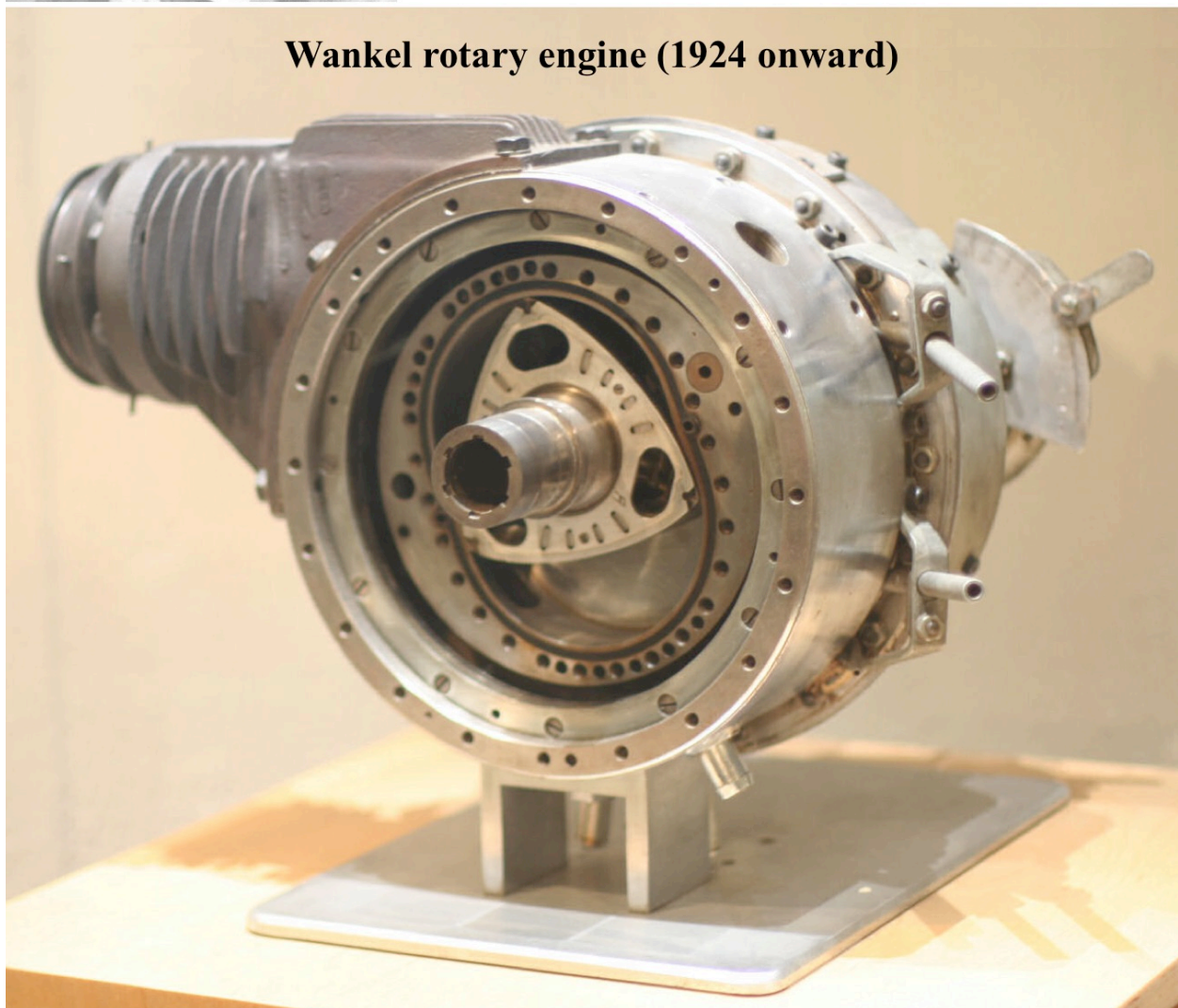


Figure 7.44: Felix Wankel developed Wankel rotary engines from 1924 onward, and Hanns Paschke later developed additional versions of Wankel engines.

In addition to the transfer of engine and automotive technologies out of the German-speaking world that occurred in the late nineteenth and early twentieth centuries, Allied countries removed an enormous amount of information on more advanced engine and automotive technologies at the end of World War II. The United States, United Kingdom, France, and Soviet Union removed engineers, prototypes, patents and other documents, and even whole factories. They also wrote detailed reports about the German and Austrian technologies that were transferred to Allied industries. For a few examples, see Figs. 7.45–7.47. There are a large number of additional examples among the BIOS ER, BIOS, BIOS Misc., BIOS Overall, CIOS ER, CIOS, FIAT, *FIAT Review*, JIOA, NavTecMisEu LR, and NavTecMisEu reports in the Bibliography.

Many other automotive-related technologies were also developed in the German-speaking world and then transferred to other countries. Examples include:

- Synthetic rubber for tires (p. 656).
- Synthetic oil for engine lubrication (p. 720).
- High-temperature metal alloys for engines with higher fuel efficiencies (p. 689).
- High-temperature ceramics for engine components (p. 667).
- Improved battery technologies (p. 615).
- Piezoelectric and photoelectric sensors inside engines to monitor engine performance in real time [e.g., pp. 1129–1130 and FIAT 575, *Developments in Diesel Engineering*].
- Fuel additives to prevent knocking in engines [e.g., BIOS 1612, *Fundamental Work on Combustion in Germany*].
- Nitrous oxide for short-term boosting of engines [e.g., BIOS 1612, *Fundamental Work on Combustion in Germany*].

As shown in Fig. 7.48, Walter Linderer (German, 19??–19??) filed the first patent on an automotive airbag in 1951. During World War II, a great deal of German research was focused on developing rapidly deployable vehicle safety devices such as ejection seats, parachutes, and chemically heated/inflatable clothing for water landings (Section 9.4). Moreover, many patent applications filed in the early years of the postwar West German patent office were based on wartime work. Therefore, it seems likely that Linderer’s airbag patent was based on wartime projects. More archival research is needed to investigate the origins of Linderer’s invention.

In order to make a truly practical airbag, it was necessary to develop a system that could fully inflate the airbag within less than 0.1 seconds during a collision. Working for Daimler-Benz, Helmut Patzelt (German?, 19??–??), Gerhard Schiesterl (German?, 19??–??), and Albert Seybold (German?, 19??–??) solved that problem. They developed an airbag deployed by a solid propellant gas generator in 1967, and they patented the system in 1971 (Fig. 7.49).

The solid propellant gas generator was essentially a miniature solid propellant rocket that used the exhaust gas to inflate the airbag. That aspect of the invention drew heavily upon the earlier development of solid explosives (Section 3.4) and solid propellant rockets (Section 9.8) in the German-speaking world.

German-designed airbag technology was rapidly copied and adopted by Japanese and American automobile manufacturers.



Hallock EXT-2506

OPB-271

Advance Release For  
Wednesday, July 3, 1946

## OFFICE OF THE PUBLICATION BOARD

German-built diesel engines have more power in relation to their weight than American-made diesels, according to a U. S. Army Transportation Corps report now on sale by the Office of the Publication Board, Department of Commerce.

However, American engines last considerably longer than German ones.

The Army's preliminary comparison of a popular, slow-speed, long-life, high-powered American diesel engine with a German diesel of similar size and application revealed that the German engine could produce 25 percent more power at approximately 31 percent less engine speed, with the same ratio of pounds to horsepower and within approximately the same space requirements.

The standard light-weight German diesel has more than twice as much horsepower per cylinder as the largest, high-speed, light-weight diesel engine made in America, though the German engine is built on the four-cycle, and the American one on the two-cycle principle, according to the report. In pounds per horsepower, the German engine is 22 percent lighter than the American engine. The ratio of horsepower to space occupied is about the same for the two engines.

The Army's studies reveal that the Germans had made far-reaching advances in the diesel field before and during both world wars. Several years in advance, they began to prepare for military demands by developing high performance engines. Under the Hitler regime, engine manufactures were heavily subsidized by the Government, and available technical skill was funneled into their research laboratories and experimental plants.

Some of these German developments, made at a probable sacrifice of progress in the commercial field, may not prove to be economically adaptable by America's peacetime industry. In order to save as much weight as possible, the Germans adopted many features which might be considered too costly by American standards, since they require a larger number of parts and more man-hours.

Other developments may help to advance the American industry. "With the unparalleled capacity of our engineers to produce complex machinery in mass production, it appears highly desirable to investigate the basic technical developments of the German designers, with the view of making these advancements practical for mass production and thereby economical for military as well as commercial application," the report states.

- 2 -

In addition to three charts comparing American and German diesel engines, the report contains numerous diagrams of German diesels.

Orders for the report (PB-1710; photostat, \$2; microfilm, 50 cents; 18 pages) should be addressed to the Office of the Publication Board, Department of Commerce, Washington 25, D. C., and should be accompanied by check or money order, payable to the Treasurer of the United States.

NARA RG 40, Entry UD-75,  
Box 3, Folder Press Releases

Figure 7.45: This is an example from the large number of reports on German automotive technologies that were sent to other countries after World War II [NARA RG 40, Entry UD-75, Box 3, Folder Press Releases].



DECLASSIFIED  
Authority NND 908618



Weed EXT-2770

OTS-395

Advance Release For  
Monday, September 23, 1946

OFFICE OF TECHNICAL SERVICES

Plans for a 2-cylinder, 25-horsepower, air-cooled diesel engine for the German light automobile, "Volkswagen," are described in a report now on sale by the Office of Technical Services, Department of Commerce. The diesel unit was intended to be interchangeable with the gasoline engines used in the "Volkswagen" but not a single engine was ever built, according to the report.

The report was prepared by a joint American-British investigating team in May, 1945, for the combined Intelligence Objectives Sub-Committee. One section of the report, which may be purchased separately, describes the diesel engine for the "Volkswagen." However, most of the report is devoted to the research activities in tank construction at the Porsche plants in Stuttgart and Fallersleben.

The Porsche firm, named after a noted German engineer, originally developed the "Volkswagen" or "people's car." Shortage of gasoline was the incentive for development of the new replacement unit for the "Volkswagen." Designs were completed by May, 1945.

Plans for the new engine, which was to have two cylinders horizontally opposed, called for the following specifications: a 3.346-inch bore; 3.937-inch stroke; 34.63 cubic inch cylinder capacity; 1:17.5 compression ratio; 24.7 horsepower maximum output at 2400 rotations per minute; and 2000 rotations per minute continuous speed with 21.7 horsepower output. The weight of the diesel engine was to be about 221 pounds, 38 pounds more than the weight of the gasoline engine. The use of compression ignition and air cooling in a 25-horsepower engine of this type are novel features, according to the report.

Complete specification data on the engine, including drawings, are contained in the report.

The remainder of the report deals chiefly with German developments in tank designs, particularly the "Maus" tank, weighing 185 British tons. One section contains data, including photographs, of a light tractor designed to operate on gas produced from burning wood chips.

The report contains charts and diagrams pertaining to the equipment discussed. Some of the drawings will not reproduce well.

Orders for the complete report (War-time Activities of Dr. Porsche, K.G.; PB-23024; photostat, \$29; microfilm, \$4.50; 435 pages) should be addressed to the Office of Technical Services, Department of Commerce, Washington, 25, D. C., and should be accompanied by check or money order, payable to the Treasurer of the United States.

Those desiring only that section of the report which deals with the new "Volkswagen" engine should order Report PB-36282 (Two-Cycle Air-Cooled Engine for Volkswagen; photostat, \$4, microfilm, \$2).

NARA RG 40, Entry UD-75,  
Box 3, Folder Press Releases

Figure 7.46: This is another example from the large number of reports on German automotive technologies that were sent to other countries after World War II [NARA RG 40, Entry UD-75, Box 3, Folder Press Releases].

DECLASSIFIED  
Authority NNS 908618

**NARA RG 40, Entry UD-75,  
Box 3, Folder Press Releases**

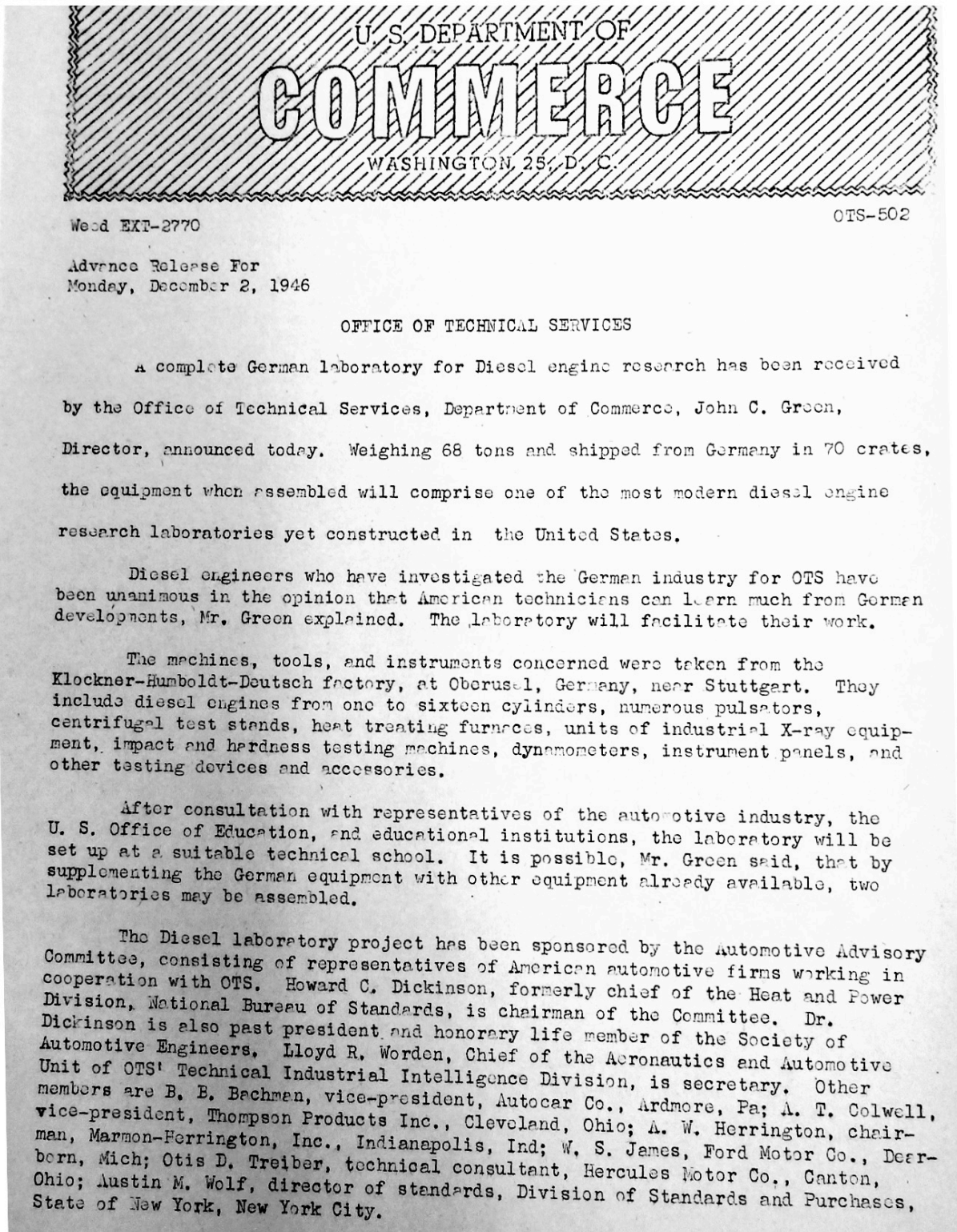
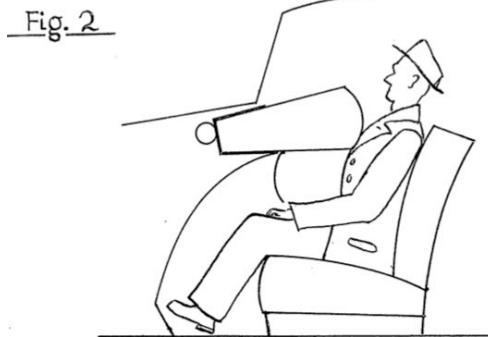
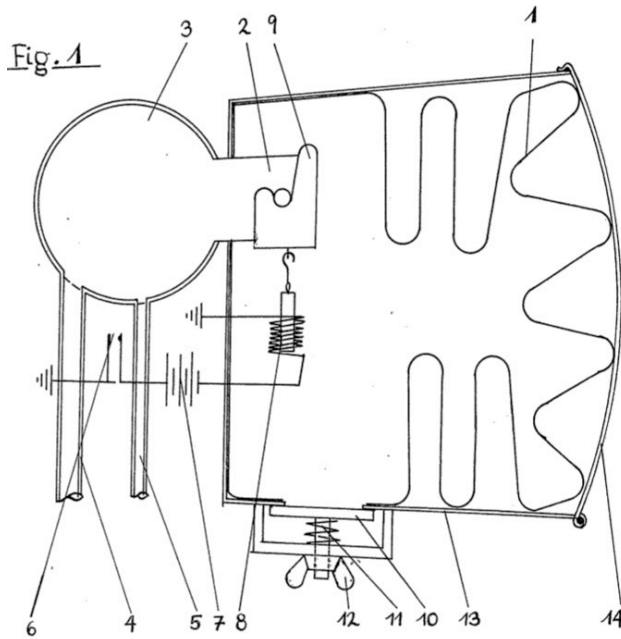


Figure 7.47: This is another example from the large number of reports on German automotive technologies that were sent to other countries after World War II [NARA RG 40, Entry UD-75, Box 3, Folder Press Releases].

Walter Linderer (19??-19??)



AUSGEGEBEN AM  
12. NOVEMBER 1953

DEUTSCHES PATENTAMT

PATENTSCHRIFT

Nr. 896 312

KLASSE 63c GRUPPE 70

L 10277 11/63c

Walter Linderer, München  
ist als Erfinder genannt worden

Walter Linderer, München

Einrichtung zum Schutze von in Fahrzeugen befindlichen Personen  
gegen Verletzungen bei Zusammenstößen

Patentiert im Gebiet der Bundesrepublik Deutschland vom 6. Oktober 1951 an  
Patentanmeldung bekanntgemacht am 26. Februar 1953  
Patenterteilung bekanntgemacht am 1. Oktober 1953

**Airbag  
(patented 1951,  
likely based on  
wartime work?)**

Bei Zusammenstößen von Kraftwagen entstehen die meisten Verletzungen dadurch, daß die Insassen nach vorn geschleudert werden und dabei gegen harte Gegenstände stoßen, an denen sie sich Verletzungen zuziehen. Um derartige Verletzungen zu vermeiden, sind schon verschiedene Vorrichtungen vorgeschlagen worden, die jedoch meist teuer in der Herstellung und kompliziert sowie nicht immer sicher in der Funktion sind.

Demgegenüber bezieht sich die Erfindung auf eine sehr einfache Einrichtung, deren Funktionsfähigkeit die Insassen des Fahrzeuges jederzeit überprüfen können und die die Bequemlichkeit des Fahrzeuges nicht einschränkt. Gemäß der Erfindung wird vor dem Sitz der zu schützenden Person ein aufblasbarer Behälter in zusammengefaltetem Zustand montiert, der sich im Fall der Gefahr automatisch oder durch willkürliche Auslösung aufbläht, so daß die betreffende Person bei einem Zusammenstoß gegen diesen weichen, elastischen Behälter geschleudert wird, wo sie keine Verletzungen erleidet.

In der Zeichnung ist ein Ausführungsbeispiel der Erfindung schematisch dargestellt und nachstehend beschrieben, ohne daß die Erfindung jedoch auf diese Ausführungsform beschränkt sein soll.

Fig. 1 zeigt die Einzelheiten der Vorrichtung und Fig. 2 den im Fall der Gefahr aufgeblähten Behälter im Innern eines Kraftwagens.

Vor dem Sitzplatz der Insassen bei einem Kraftwagen, also zweckmäßig für die Vordersitze am Armaturenbrett oder an der Decke des Wagens, für die Rücksitze an der Rückseite der Vordersitze, befindet sich ein zusammenlegbarer elastischer und möglichst wenig luftdurchlässiger Behälter 1, der durch ein Ventil 2 mit einem Preßluftbehälter 3 in Verbindung steht. Als Preßluftquelle kann eine Preßluftflasche dienen oder auch ein Hohlgefäß, das mit einer anderweitig gelagerten Preßluftflasche oder einem Kompressor durch eine Leitung 4 verbunden ist. Ein zweckmäßig am Armaturenbrett befestigtes Manometer zeigt über die Leitung 5 den in Raum 3 herrschenden Luftdruck an, so daß

Figure 7.48: Walter Linderer filed the first patent on an automotive airbag in 1951 (likely based on wartime work?).



**Helmut Patzelt**  
(19??-??)

**Gerhard Schiesterl**  
(19??-??)

**Albert Seybold**  
(19??-??)

19 BUNDESREPUBLIK  
DEUTSCHLAND



DEUTSCHES  
PATENTAMT

12 Patentschrift  
11 DE 21 52902 C2

51 Int. Cl. 3:  
B60R21/10

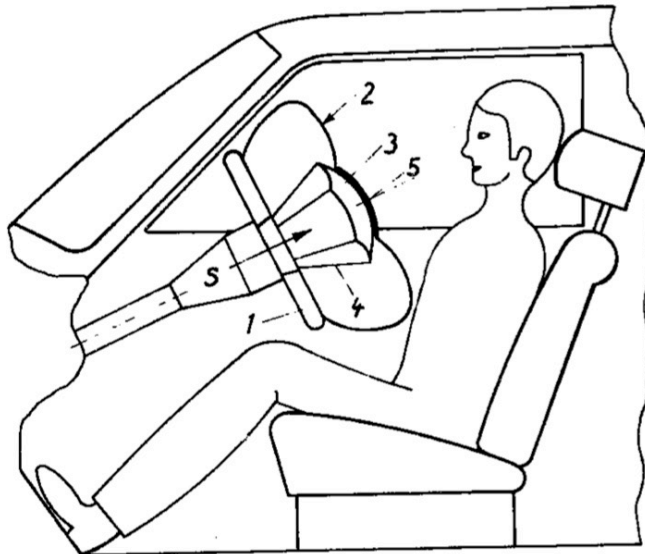
21 Aktenzeichen: P 21 52 902.2-21  
22 Anmeldetag: 23. 10. 71  
43 Offenlegungstag: 26. 4. 73  
55 Veröffentlichungstag: 2. 8. 82

Innerhalb von 3 Monaten nach Veröffentlichung der Erteilung kann Einspruch erhoben werden

73 Patentinhaber:  
Daimler-Benz AG, 7000 Stuttgart, DE

61 Zusatz zu: P 21 11 898.9

72 Erfinder:  
Patzelt, Helmut, 7012 Fellbach, DE; Schiesterl, Gerhard,  
7000 Stuttgart, DE; Seybold, Albert, 7300 Esslingen, DE



**Airbag deployed by  
a solid propellant  
gas generator  
(1967)**



Figure 7.49: Helmut Patzelt, Gerhard Schiesterl, and Albert Seybold developed an airbag deployed by a solid propellant gas generator in 1967, and they patented the system in 1971.

### 7.3.2 Chainsaws

German-speaking creators also invented chainsaws and adapted internal combustion engines to power them (Fig. 7.50).

Sometime before 1830, Bernhard Heine (German, 1800–1846) invented hand-powered chainsaws (osteotomes) for cutting bone during surgery, and then in 1830 he successfully promoted their use all over Europe. Heine was a surgeon who also made important discoveries about bone growth and bone repair. He likely would have made even more contributions during his career, but unfortunately he died from tuberculosis (probably acquired from his work).

In the late 1920s, Andreas Stihl (Swiss, educated and worked in Germany, 1896–1973), a mechanical engineer, developed both electric and gasoline-powered chainsaws. Based on his inventions, he founded the company that still bears his name.

At the same time, Emil Lerp (German, 1886–1966) also developed gasoline-powered chainsaws and founded the Dolmar company to produce them. Early in their careers, Lerp and Stihl worked together for the Emil Ring saw company, so it is somewhat murky whether one of them borrowed the ideas of the other, or if they developed their chainsaws truly independently.

Chainsaw designs were spread worldwide both by the Stihl and Dolmar companies and by Allied investigators at the end of World War II [see for example FIAT 696, *Gasoline Powered Hand Tree Saws*].

**Bernhard Heine**  
(1800–1846)

Manual chainsaw

**Andreas Stihl**  
(1896–1973)

Electric & gas chainsaws

**Emil Lerp**  
(1886–1966)

Gasoline chainsaw



Nr. 133857 Klasse 80a  
SCHWEIZERISCHE EIDGENOSSENSCHAFT  
EIDGEN. AMT FÜR GEISTIGES EIGENTUM  
**PATENTSCHRIFT**  
Veröffentlicht am 2. September 1929

Gesuch eingereicht: 7. September 1928, 17 Uhr. — Patent eingetragen: 30. Juni 1929.

HAUPTPATENT

Andreas STIHL, Stuttgart (Deutschland).

Elektrische Handkettensäge.

Die Erfindung bezieht sich auf Kettensagen, welche mittelst eines Elektromotors angetrieben werden.

Gemäß der Erfindung ist der Motor und das erforderliche Zwischengetriebe über dem Kettensäge angeordnet.

Die Erfindung ist an einem Ausführungsbeispiel anhand der Zeichnung nachstehend beschrieben.

Fig. 1 zeigt eine gekürzte Seitenansicht der Handäge.

Fig. 2 eine Draufsicht.

Fig. 3 einen Querschnitt nach der Linie IV—IV der Fig. 1.

Die Handäge weist einen Motor *a* auf, an dessen Gehäuse die Lagerdeckel *c* und *b* angeflanscht sind. Der Lagerdeckel *c* trägt zugleich das Lagergehäuse *d* für das Getriebe, bei welchem zum Beispiel die Motorwelle *e* über eine Zwischenwelle *f* das Kettensäge

über die Schiene *i*, welche zur Führung der Sägekette *h* dient, verlegt und daher eine gleichmäßige Verteilung des Gewichtes und auch ein gleichmäßiger Schnitt erzielt werden kann. Das Kettensäge *g* treibt in bekannter Weise eine mit Zähnen versehene Sägekette *h*, welche über die Schiene *i* geführt ist und am dem Kettensäge *g* gegenüberliegenden Ende der Schiene über ein Wandler *j* läuft. Die Schiene *i* ist an einem seitlichen Arm *k* des Motorgehäuses *a* angebracht, der zugleich eine Lagerstelle für die Welle des Kettensäges *g* aufweist. Um eine sichere Führung der Kette *h* beim Schnitt und einen geraden Schnitt zu erhalten, ist die Schiene *i* an ihrer Unter- und Oberseite je mit einer Führungsrille *l* versehen, in welcher die Kette *h* mit ihrer nichtschneidenden Innenseite läuft. Zum Tragen der Säge dient einerseits ein Gabelgriff *m*, dessen beide seitlichen Schenkel *n* an den Lagerdeckeln *b*

Fig. 1.

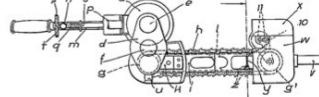


Fig. 2.

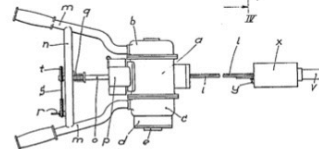
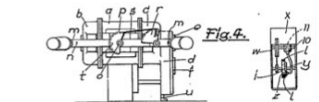


Fig. 3.



RÉPUBLIQUE FRANÇAISE.  
MINISTÈRE DU COMMERCE ET DE L'INDUSTRIE.  
DIRECTION DE LA PROPRIÉTÉ INDUSTRIELLE.  
**BREVET D'INVENTION.**  
Gr. 5. — Cl. 4. N° 676.716

Scie à chaîne sans fin pour l'abatage des arbres.

M. Em. LERP résidant en Allemagne.

Demandé le 14 juin 1929, à 14<sup>h</sup> 50<sup>m</sup>, à Paris.

Déposé le 29 novembre 1929. — Publié le 26 février 1930.

(Demande de brevet déposée en Allemagne le 14 juin 1928. — Déclaration de dépôt.)

La scie à chaîne sans fin pour abattre les arbres, faisant l'objet de la présente invention, se distingue par la possibilité de transport et de montage spécialement simples. Elle repose de préférence sur trois pieds fixés sur des tiges, tubes, etc., verticalement déplaçables susceptibles d'être calés à hauteur voulue par un dispositif d'arrêt et pouvant être abaissés par simple pression exercée sur leurs extrémités supérieures. La scie comprend en outre deux paires de poignées se faisant face, aménagées de telle sorte sur la machine qu'elle puisse être transportée comme une civière et que les tiges de réglage des pieds se trouvent à proximité des porteurs. Ceci est notamment à même après avoir lâché l'une ou

machines comme une brèche. La culasse de commande de la scie à chaîne sans fin est en général assujétie d'une manière élastique avec le rail de guidage de la scie afin que ce dernier puisse se mouvoir dans le sens de la hauteur, et ce dans un but qui sera exposé plus loin.

An dessin annexé, donné à titre d'exemple, une forme d'exécution de la scie à été représentée, et à ce dessin :

Fig. 1 est une vue de face partielle de la machine, en la regardant du côté de la culasse de commande et du rail de guidage de la scie sans fin et ce dans une position où la scie dans laquelle la scie et son guide travaillent dans un plan horizontal; Fig. 2 est une coupe partielle par la culasse

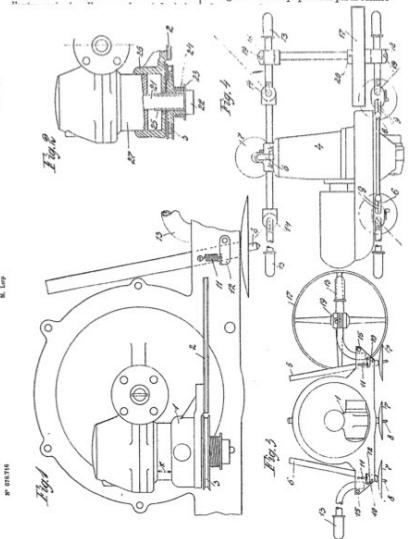


Figure 7.50: Bernhard Heine invented hand-powered chainsaws in 1830, Andreas Stihl developed electric and gasoline-powered chainsaws in the late 1920s, and Emil Lerp developed gasoline-powered chainsaws in the late 1920s.



### 7.3.3 Tanks

German-speaking creators were responsible for most of the major innovations in the development of military tanks powered by internal combustion engines or gas turbine engines.

As shown in Fig. 7.51, Frederick Simms (German, 1863–1944) developed the small armed Motor Scout in 1899, followed by the much larger Motor War Car in 1902. Then in 1904, Paul Daimler (German, 1869–1945) and his team developed the Panzerwagen armored car, pictured in Fig. 7.52.

In or before 1911, Günther Burstyn (Austrian, 1879–1945) invented the first combat tank to incorporate all of the major features of modern tanks (including treads, full armor, a large lower motor section, a smaller rotating turret with a long gun barrel of large caliber, and armored ports for smaller guns), as illustrated in Figs. 7.53–7.55. He tried unsuccessfully to interest many countries in funding him to mass-produce his combat tank, along the way publicizing his tank plans via presentations, patents (e.g., Fig. 7.54), and articles (e.g., Fig. 7.55). For example, he published a 1912 article that summarized the main features of his tank designs and included many accompanying diagrams [Burstyn 1912]:

Die Bewegung im Gelände, besonders auf weichem Boden, erfolgt mit einem Paar über kleine breite Räder geführter endloser Bänder aus Drahtseilgeflecht. Diese Bänder fassen mit Rippen in den Boden ein und werden durch die äußeren, hochgestellten Räder, in welche sie zahnradartig eingreifen, angetrieben. Durch die Hochstellung dieser Räder sind die Bänder vorne und rückwärts schräg aufwärtsgeführt, so daß kleine Unebenheiten leicht überwunden werden können. Wendungen geschehen in der Weise, daß ein Band nach vorne, das andere nach rückwärts zum Antrieb gelangt. Im allgemeinen ist es das alte Prinzip der sich selbst Geleise legenden Lokomotive, das in letzter Zeit in ähnlicher Weise für Motorschlitten der antarktischen Expeditionen mit Erfolg angewendet wird.

Zur Überschreitung von Hindernissen sind vorne und rückwärts an dem Fahrzeuge je zwei breite Gleitschienen, die an den äußeren Enden breite kleine Räder tragen, auslegerartig angebracht. Diese Gleitschienen sind um ihren Befestigungspunkt am Fahrzeuge im vertikalen Sinne schwenkbar und werden durch je eine Strebe gestützt. Die Schwenkung der Gleitschienen erfolgt durch die Streben, welche durch ein Getriebe, das vom Motor betätigt wird, entsprechend bewegt werden. Die Figuren 5–10 [Fig. 7.55] machen ersichtlich, wie das Motorgeschütz mit Hilfe der Gleitschienen eine Stufe überschreitet.

Movement in the terrain, especially on soft ground, is accomplished by a pair of endless belts made of braided wire rope guided over small wide wheels. These belts engage the ground with ribs and are driven by the outer raised wheels in which they mesh like cogwheels. Because of the raised position of these wheels, the belts are slanted upward at the front and back, so that small bumps can be easily overcome. Turns are executed in such a way that one belt is driven to move forward and the other backward. In general, it is the old principle of a locomotive laying tracks for itself, which has recently been successfully used in a similar way for snowmobiles on Antarctic expeditions.

In order to cross obstacles, two wide slide rails are attached to the front and two to the rear of the vehicle in the form of outriggers, which carry wide small wheels at the outer ends. These slide rails can be pivoted vertically about their point of attachment to the vehicle and are each supported by a strut. The pivoting of the slide rails is effected by the struts, which are moved accordingly by a gear operated by the motor. Figures 5–10 [Fig. 7.55] show how the motorized gun crosses a step with the aid of the slide rails.

Mit Hilfe der beschriebenen Fortbewegungsmittel erscheint die freie Bewegung des Motorgeschützes im Gelände gewährleistet. Hierbei sind zwei Geschwindigkeitsstufen erforderlich: eine normale (5–8 km pro Stunde) für das Fahren über freies Feld und eine langsame (zirka 3 km pro Stunde) für das Übersetzen von Hindernissen.

Zur raschen Bewegung auf Straßen, zu der die bisher beschriebene Art der Fortbewegung ungeeignet ist, sind zwei Paare von Rädern vorgesehen. Sie befinden sich unter dem Panzer und sind zum Heben, bzw. Senken eingerichtet. Die vorderen Räder beim Geschütz werden gelenkt, die rückwärtigen angetrieben. Die Geschwindigkeit, die auf Straßen erzielt werden soll, wird je nach der Motorstärke 20–30 km pro Stunde betragen.

Der Aufbau des Motorgeschützes ist so eingerichtet, daß sich vorne der Kampfraum, rückwärts der Motorraum befindet.

Der erstere wird oben durch eine drehbare Panzerhaube gebildet, die mit der Lafettierung des Geschützes in Verbindung steht. Auf dieses wird später näher eingegangen werden. Ferners befinden sich im Kampfraume für die zwei Mann Geschützbedienung Sitze, welche sich bei der Drehung der Haube mitbewegen.

Im Motorraum ist ein 40–60 H.P. Benzinmotor (Last wagentype) installiert. Ferners befindet sich dort der Sitz für den Motorwärter. Beiderseits von diesem sind geräumige Kästen zur Aufnahme von Benzin, Öl, Munition und Requisiten vorgesehen. Während des Feuergefechtes läßt sich der Motor mit dem Kampfraum verbinden, so daß der Motorwärter die Zureichung der Munition besorgen kann.

With the help of the described means of locomotion, the free movement of the motor gun in terrain appears to be ensured. Two speed levels are required: a normal one (5–8 km per hour) for driving over open fields and a slow one (about 3 km per hour) for crossing obstacles.

For rapid movement on roads, for which the mode of locomotion described so far is unsuitable, two pairs of wheels are provided. They are located under the tank and are designed to be lifted or lowered. The front wheels on the gun are steered and the rear wheels are powered. The speed to be achieved on roads will be 20–30 km per hour, depending on the engine power.

The superstructure of the motorized gun is arranged so the fighting compartment is in the front and the engine compartment in the rear.

The former is formed at the top by a rotatable armored turret, which is connected to the mount of the gun. This will be discussed in more detail later. Furthermore, there are seats in the fighting compartment for the two-man gun crew, which move along with the rotation of the turret.

A 40–60 H.P. gasoline engine (truck type) is installed in the engine compartment. There is also a seat for the engine attendant. On either side of this are spacious boxes for storing gasoline, oil, ammunition, and props. During the firefight, the engine compartment can be connected to the fighting compartment, so that the engine attendant can resupply the ammunition.

Der Panzerschutz, welcher gleichzeitig den tragenden Rahmen für das Fahrzeug bildet, besteht aus Spezialstahl und ist vorne mit 8 mm, seit- und rückwärts mit 4 mm, an der Decke mit 3 mm Stärke angenommen. Die Panzerung nach unten gegen Geller wird wahrscheinlich auch notwendig werden.

The armor protection, which also forms the supporting frame for the vehicle, is made of special steel and is assumed to be 8 mm thick at the front, 4 mm thick at the sides and rear, and 3 mm thick on top. Underside armor against piercing will probably also be necessary.

Das Motorgeschütz, das infolge dieses Panzerschutzes gegen Infanteriefeuer fast unverwundbar erscheint, muß natürlich in der feindlichen Artillerie seinen stärksten Gegner erblicken und befähigt sein, den Kampf mit diesem zu bestehen.

The motorized gun, which as a result of this armor protection appears almost invulnerable to infantry fire, will of course find its strongest opponent to be enemy artillery and must be capable of holding its own against it.

Note that in addition to all of the now-common features of tanks, Burstyn's designs included two other novel options: retractable wheels underneath to allow faster travel on paved roads, and extendable wheeled beams on the front and back to aid in crossing over trenches.

Even though Burstyn was never able to find enough funding to fully develop his tanks himself, by widely publicizing his approach and designs through his international presentations, patents, and publications, it appears that he directly influenced engineers in several countries to implement his tank ideas for themselves during World War I.

Joseph Vollmer (German, 1871–1955) developed the first internal-combustion-engine-powered tractor-trailer truck in 1903; see Fig. 7.56. During World War I, he built upon the ideas of Günther Burstyn to create tanks such as the A7V.

As shown in Fig. 7.57, during World War II, Ferdinand Porsche, Karl Rabe, and their team developed advanced tanks such as the widely used Tiger I. They also created the huge 188-ton Panzerkampfwagen VIII Maus prototype [Ludvigsen 2015].

Another large tank prototype, the 140-ton Henschel Panzerkampfwagen E-100, was taken by British troops at the end of World War II. It is shown in Fig. 7.58 on top of a trailer, without the turret and treads.

Nicholas Straussler (Hungarian, 1891–1966), an automotive engineer, emigrated to the United Kingdom in the late 1920s due to rising intolerance in central Europe. From 1940 to 1944, he developed the duplex drive (DD) amphibious tanks that were used by Allied forces for the invasion of Normandy (Fig. 7.59).

German-speaking creators and their creations continued to influence tank design after World War II. In September 1945, R. P. Linstead and T. J. Betts, the British and American chairs of the Combined Intelligence Objectives Subcommittee (CIOS), listed a number of important German innovations for tanks that were of interest to Allied countries [AFHRA A5186 electronic version pp. 904–1026, Ch. 4, pp. 68–69]:



Investigation of the German automotive industry revealed that development was concentrated on armored fighting vehicles to the exclusion of ordinary motor transport. A new series of super heavy tanks, a group of self-propelled weapons known as “Waffentraeger”, another series of tanks designated as the “E-Series” and the application of gas turbines as tank power plants were of particular interest.

The pilot model of the E-100 tank was located, and drawings of the important assemblies were evacuated by investigators. This tank weighed approximately 100 metric tons, mounted a 150 mm. gun and was provided with a sloping front armor plate 8 inches thick. It was discovered that an even heavier tank known as the “Maus” had been constructed and tested. The pilot model of this tank, which was reported to weigh 180 metric tons, was destroyed in the Russian area prior to occupation. [The Maus prototype was actually captured by the Russians—see Fig. 7.57.] However, complete engineering data on the “Maus” was obtained by CIOS investigators.

German authorities were planning mass production of self-propelled “Waffentraeger” guns. These gun mounts were lightly armored vehicles, which were to be equipped with normal field artillery weapons. It was initially conceived that provisions would be made for demounting the weapons for employment as conventional artillery pieces, but this feature was subsequently abandoned.

The “E-Series” of German tanks were the most interesting armored vehicles encountered. This series included the E-10, E-25, E-50 and E-100, all of which incorporated the most advanced thinking of the Heereswaffenamt. The series numbers represent the estimated weights of the basic chassis. It is significant to note that these vehicles represented a return of the German design trend to lighter and more maneuverable tanks.

The development of a gas turbine for tank motive power was not complete, nor had successful application been achieved. However, many US and British authorities believe that the gas turbine development is potentially the most important feature of German armored vehicle research. It was expected that a 30% increase in power would be obtained from substitution of a gas turbine for a conventional type power unit in a given size engine compartment. Considerable progress had been made on the development of a rotary ceramic heat exchanger capable of achieving fuel economy equal to that of the automotive type Diesel.

Tank armament projects included the rigidly mounted 75 and 88 mm. guns described previously. The design of gyroscopically stabilized sights led German experts to hope for an accuracy within a half-mile limit. The “Kugelblitz” anti-aircraft armored turret was discovered.

In respect to tank engines, designers had endeavored to produce an air-cooled Diesel power plant. The only successful new project encountered was the “Maybach HL-234” gasoline injection engine which had delivered 900 H.P. in preliminary tests.

The Germans had initiated many new projects of a more or less radical nature in the design of new tank transmissions. Electric drive had been tried but with little success. Turbo or torque converter-drive was considered the most promising of high horse-power applications.

BIOS 98, *Report on German Development of Gas Turbines for Armoured Fighting Vehicles*, pp. 3 and 13–14, gave more information on wartime development of gas turbine engines for tanks:

During the investigation of the activities of Dr. Ing. Porsche, it was learned that he was associated with a project for the development of a gas turbine installation for the Tiger tank. The investigation was stated to be in the hands of Dipl. Ing. Otto Zadnik[...]

The investigation of this target may be summed up briefly as follows:

(a) Otto Zadnik was actually engaged upon the design of only one portion of the tank project, viz, the transmission. Although he had an over-riding responsibility for, and good general knowledge of the whole project, he was unable to provide details of the power unit.

(b) Dr. Alfred Müller, who for some eighteen months, had been primarily responsible for turbine and turbo-blower development for aircraft (See his charter in Appendix 2) was made responsible for the design and development of the tank power unit. Dr. Müller has behind him a wide experience of gas turbines and blower development, but little or no development work appears to have been carried out on the tank motor itself. [...]

(d) The torque characteristics (Scheme II), freedom from vibration, and the absence of any cooling system, make the gas turbine very attractive for tank use. [...]

During the war, Anselm Franz (Austrian, 1900–1994) developed gas turbine engines for jet fighters (Fig. 9.76). After the war, he came to the United States, where he brought the wartime dream of a gas turbine tank engine to reality. No later than 1951, he proposed the AGT1500 turboshaft engine to power U.S. tanks. After lengthy delays obtaining government funding, Franz finally demonstrated the AGT1500 engine in 1966. As shown in Fig. 7.60, the AGT1500 is still used in the M1A1 Abrams tank. Both in Germany during the war and in the United States after the war, Franz collaborated very closely with Heinrich Adenstedt (German, 1910–1991, pp. 697–698), an expert on high-temperature metal alloys.

**Frederick Simms  
(1863–1944)**

**Simms Motor Scout (1899)**



**Simms Motor War Car (1902)**



Figure 7.51: Frederick Simms developed the small armed Motor Scout in 1899 and the much larger Motor War Car in 1902.



**Paul Daimler**  
**(1869–1945)**

**Austro-Daimler Panzerwagen**  
**armored car (1904)**

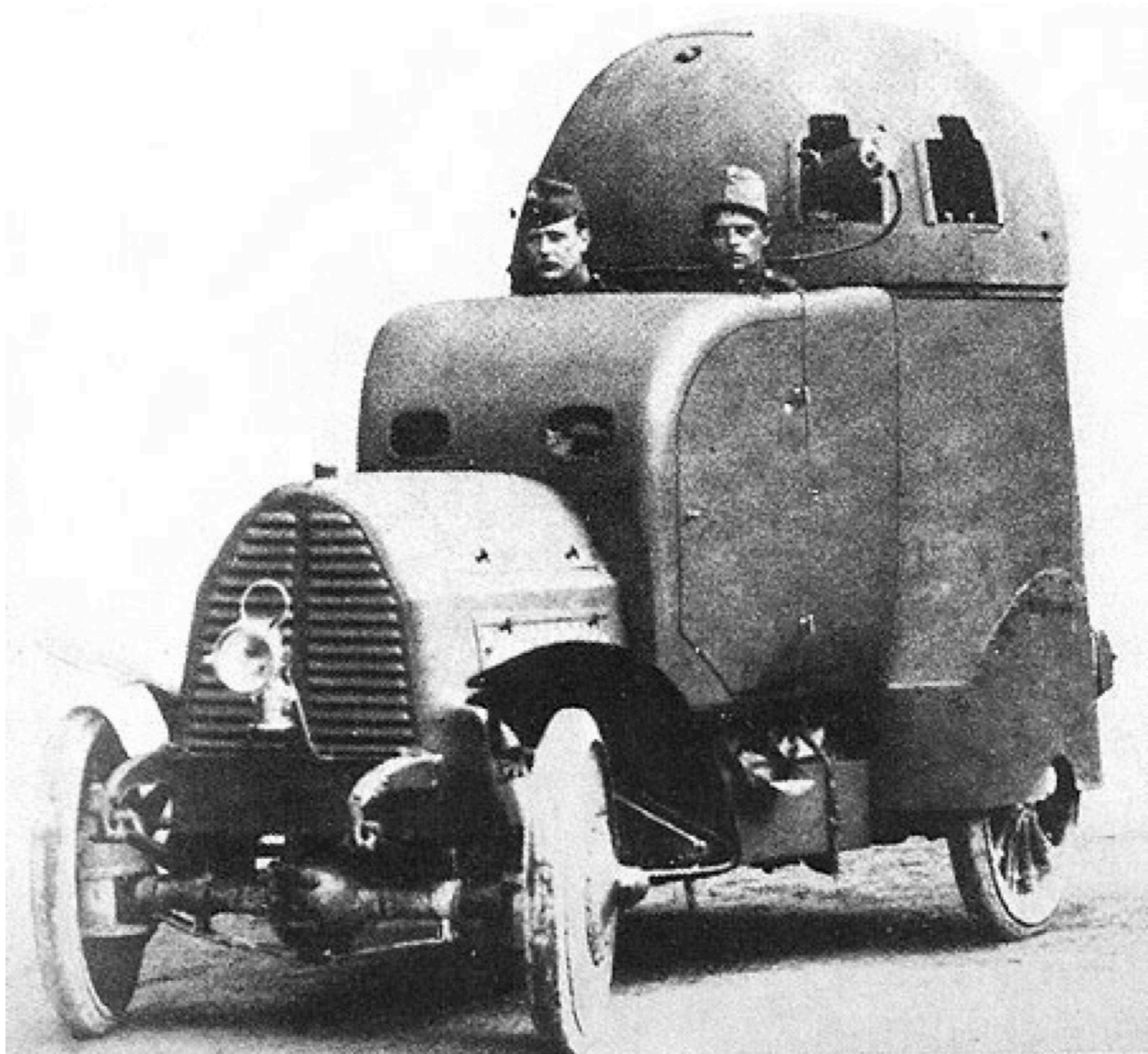


Figure 7.52: Paul Daimler and his team developed the Panzerwagen armored car in 1904.

**Günther Burstyn  
(1879–1945)**



**Burstyn combat tank (1911)**



Figure 7.53: In or before 1911, Günther Burstyn invented the first combat tank to incorporate all of the major features of modern tanks. It also had extendable wheeled beams on the front and back to aid in crossing over trenches.

## GUNTER BURSTYN IN KORNEUBURG.

## Vorrichtung für Motorfahrzeuge zum Überschreiten von Hindernissen.

Angemeldet am 1. März 1911. — Beginn der Patentdauer: 1. Jänner 1912.

Die Erfindung betrifft eine Vorrichtung, welche für Motorfahrzeuge bestimmt ist, um mit diesen Hindernisse im Terrain, wie Gräben, Stufen, Eisenbahndämme, zu überschreiten.

Die Fig. 1 und 2 zeigen die Vorrichtung für ein Motorgeschütz verwendet. Vorne und rückwärts am Fahrzeug sind je ein Paar Gleitschienen *u*, welche an den äußeren Enden kleine breite Räder *r* tragen, auslegerartig angebracht. Diese Gleitschienen sind um die Achsen *R* in vertikalem Sinne schwenkbar. Diese Bewegung erfolgt durch die die Gleitschienen stützenden Streben *a*. Das untere Ende der Streben ist in den Gleitschienen drehbar befestigt, das obere Ende zu einem Kreuzkopf *c* ausgestaltet. Dieser Kreuzkopf gleitet in den Führungen *f*; an ihm ist die fortschreitende, jedoch nicht drehbare Spindel *b* befestigt. Das Kegelrad *d* sitzt als Mutter auf der Spindel *b*. Der Antrieb des Kegelrades *d* erfolgt über das Kegelrad *e* vom Motor aus. Wird der Antrieb eingeschaltet, so dreht sich das Kegelrad *d* und bewegt als Mutter der Spindel *b* diese vor- bzw. rückwärts. Hiedurch wird der Kreuzkopf *c* ebenfalls nach vor- bzw. rückwärts bewegt, die Strebe *a* wird vor- bzw. gedrückt bzw. angezogen und auf diese Weise das äußere Ende der Gleitschienen heruntergedrückt bzw. gehoben.

Die Fig. 3, 4, 5 und 6 zeigen die Verwendung der beschriebenen Konstruktion an einem Motorgeschütz angebracht. Und zwar ist in Fig. 3 das Übersetzen eines Grabens, in den Fig. 4, 5 und 6 das Überschreiten einer Terrainstufe dargestellt.

## PATENT-ANSPRUCH:

- 20) Vorrichtung zur Übersetzung von Terrainhindernissen, insbesondere für gepanzerte, mit Geschützen armierte Motorfahrzeuge, gekennzeichnet durch am Vorder- und Hinterwagen des Fahrzeuges der Höhe nach schwenkbar angebrachte Gleitschienen (*u*), die an ihren über das Fahrzeug hinausreichenden Enden mit Rädern versehen sind und vom Innern des Fahrzeuges aus entsprechend den zu überwindenden Hindernissen des Geländes ein-
- 25) stellbar sind.

Burstyn combat tank (1911)



KAIS. KÖNIGL. PATENTAMT.

Österreichische

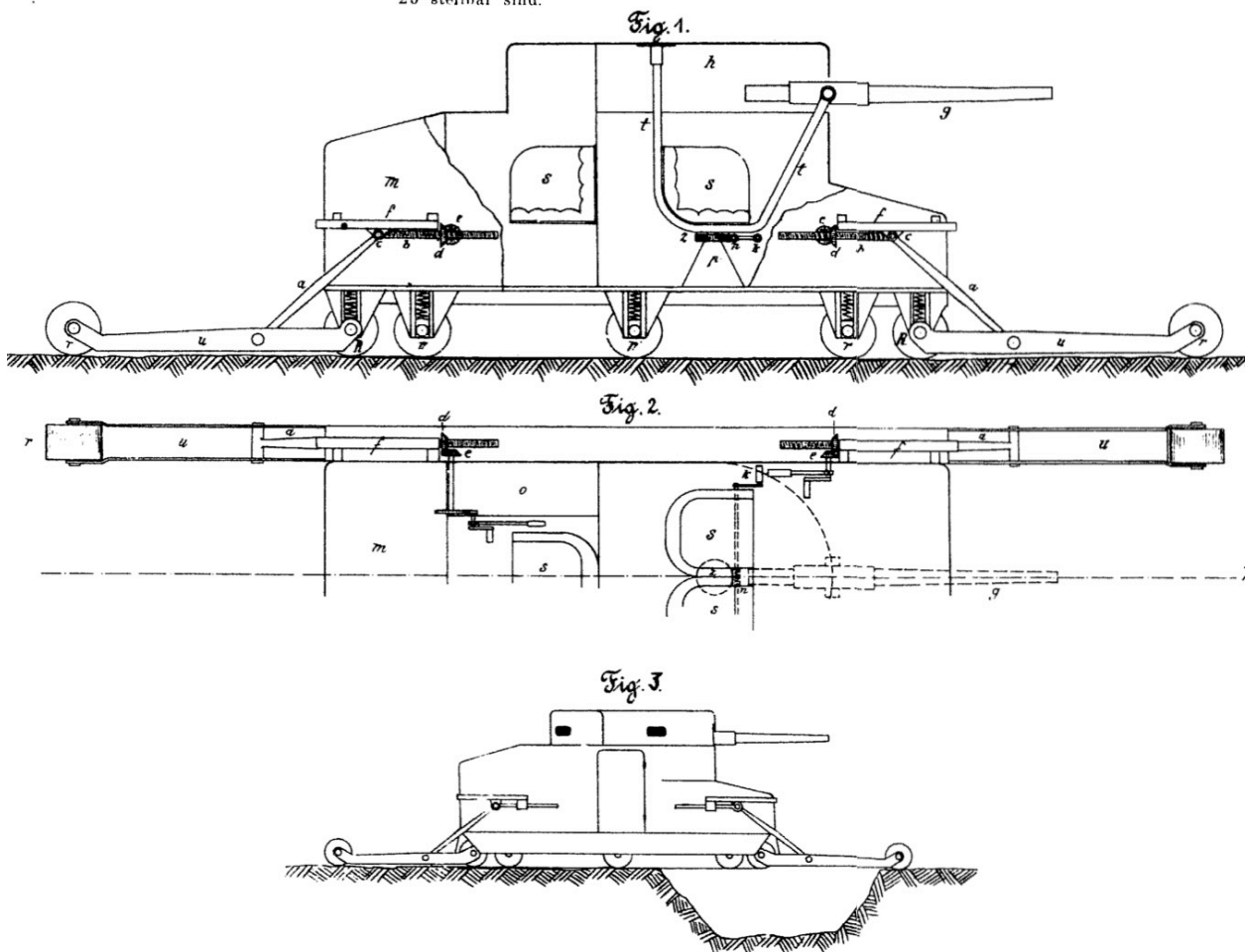
PATENTSCHRIFT N<sup>o</sup> 53248.

Figure 7.54: In or before 1911, Günther Burstyn invented the first combat tank to incorporate all of the major features of modern tanks. It also had extendable wheeled beams on the front and back to aid in crossing over trenches.



**Das Motorgeschütz.**

Von Oblt. Gunther Burstyn im k. und k. Eisenbahregiment.

Mit 10 Textfiguren.

Der Benzinmotor ist wie für die Industrie, so auch für die Kriegstechnik eine unentbehrliche Kraftquelle geworden. Er dient als solche nicht allein für das Personen- und Lastautomobil, sondern auch für die Feldstationen der drahtlosen Telegraphie und für die mobilen Scheinwerfer. Lenkballon und Aëroplan sind ohne ihn undenkbar.

Je weiter sein Verwendungsgebiet für Kriegsmittel wird, die nicht dem direkten Kampfwert dienen, desto sonderbarer muß es scheinen, daß er für aktive Kampfmittel gar nicht in Frage kommt. Dank seiner hohen Kraftäuberung bei relativ kleinem Gewicht und geringem Raumbedarf birgt er bestimmt die Verwendungsmöglichkeit für die Schaffung neuer, die Kriegführung gewiß sehr beeinflussender Kampfmittel in sich, für welche der tierische Motor infolge seines Mißverhältnisses zwischen Körper- und Kraftgröße absolut nicht in Frage kommen kann.

Daß es dem Benzinmotor bisnun noch nicht gelungen ist, in dieser Richtung Erfolge zu erzielen, darf man nicht ihm zur Last legen. Das Versäumnis trifft vielmehr jene Konstruktionen, die zur Entfaltung der vom Motor gelieferten Kraft dienen.

Zwar wurde vor einigen Jahren von den Heeresverwaltungen verschiedener Staaten der Versuch gemacht, den Kraftwagen zu panzern und zu armieren und auf diese Weise für direkte Kampfwert zu verwenden, doch endeten alle diese Versuche mit Mißerfolgen.

Die Ursache des Versagens der Panzerautomobile lag in dem Umstande, daß sie im allgemeinen wie gewöhnliche Kraftwagen konstruiert waren. Durch den Vierräderantrieb eigneten sie sich gewiß besser als gewöhnliche Automobile, auf unregelmäßigem festem Boden zu fahren, auf weichem Boden (Sturzäcker) versagten sie aber. Von entgegnetretenden Hindernissen konnten sie zwar Gräben mit Hilfe mitgeführter Brückenschienen übersetzen, doch war hiezu das Verlassen des Panzerschutzes durch die Besatzung notwendig, ein Vorgang,

Burstyn combat tank (1911)

Fig. 1. Seitenansicht.

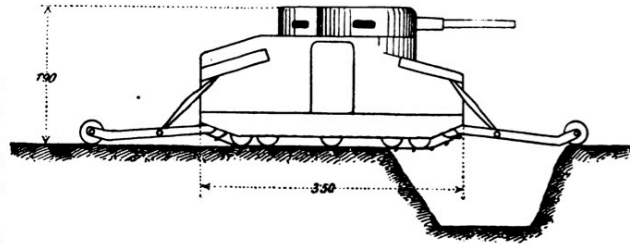


Fig. 2. Draufsicht.

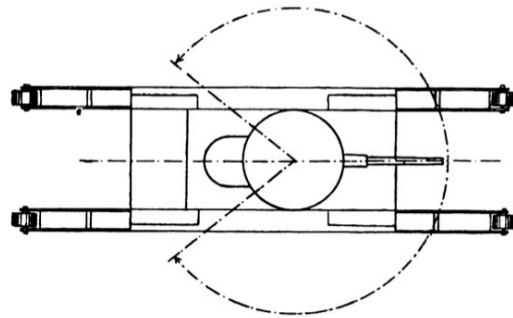


Fig. 3. Vorderansicht.

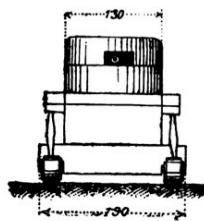


Fig. 4. Rückansicht.

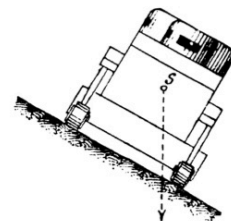


Fig. 5.

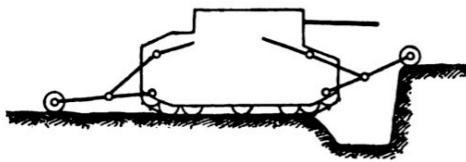


Fig. 6.

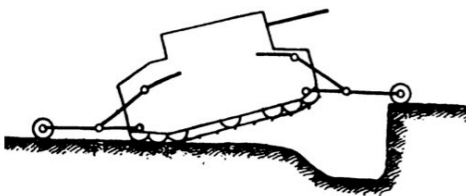


Fig. 7.

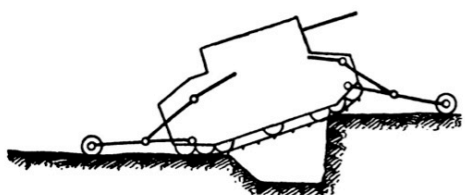


Fig. 8.

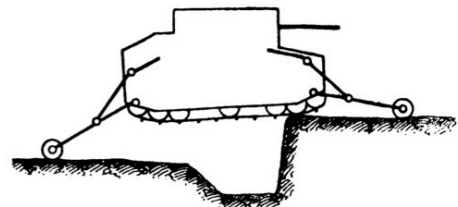


Fig. 9.

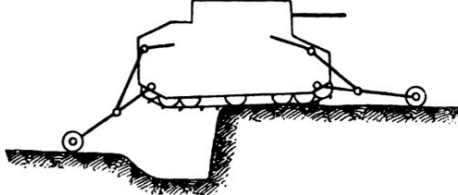


Fig. 10.

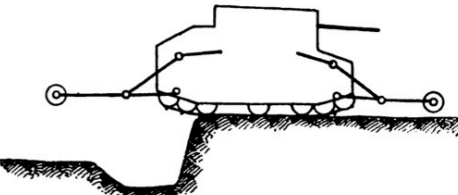
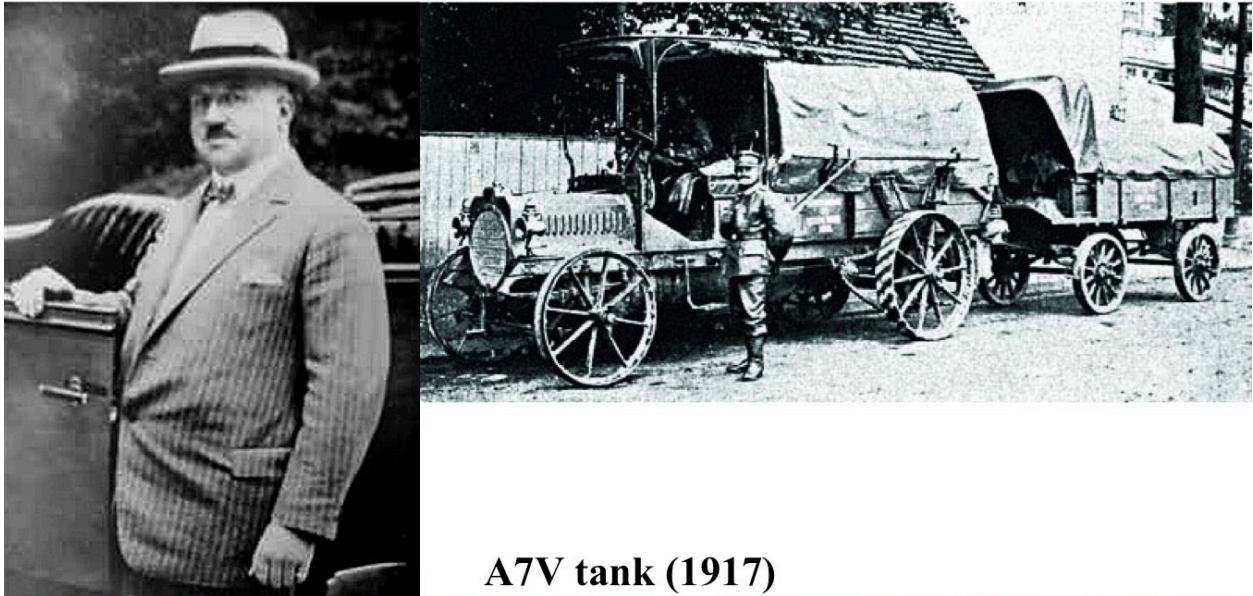


Figure 7.55: In or before 1911, Günther Burstyn invented the first combat tank to incorporate all of the major features of modern tanks. It also had extendable wheeled beams on the front and back to aid in crossing over trenches [Burstyn 1912].

**Joseph Vollmer**  
(1871–1955)

**DURCH tractor-trailer truck (1903)**



**A7V tank (1917)**

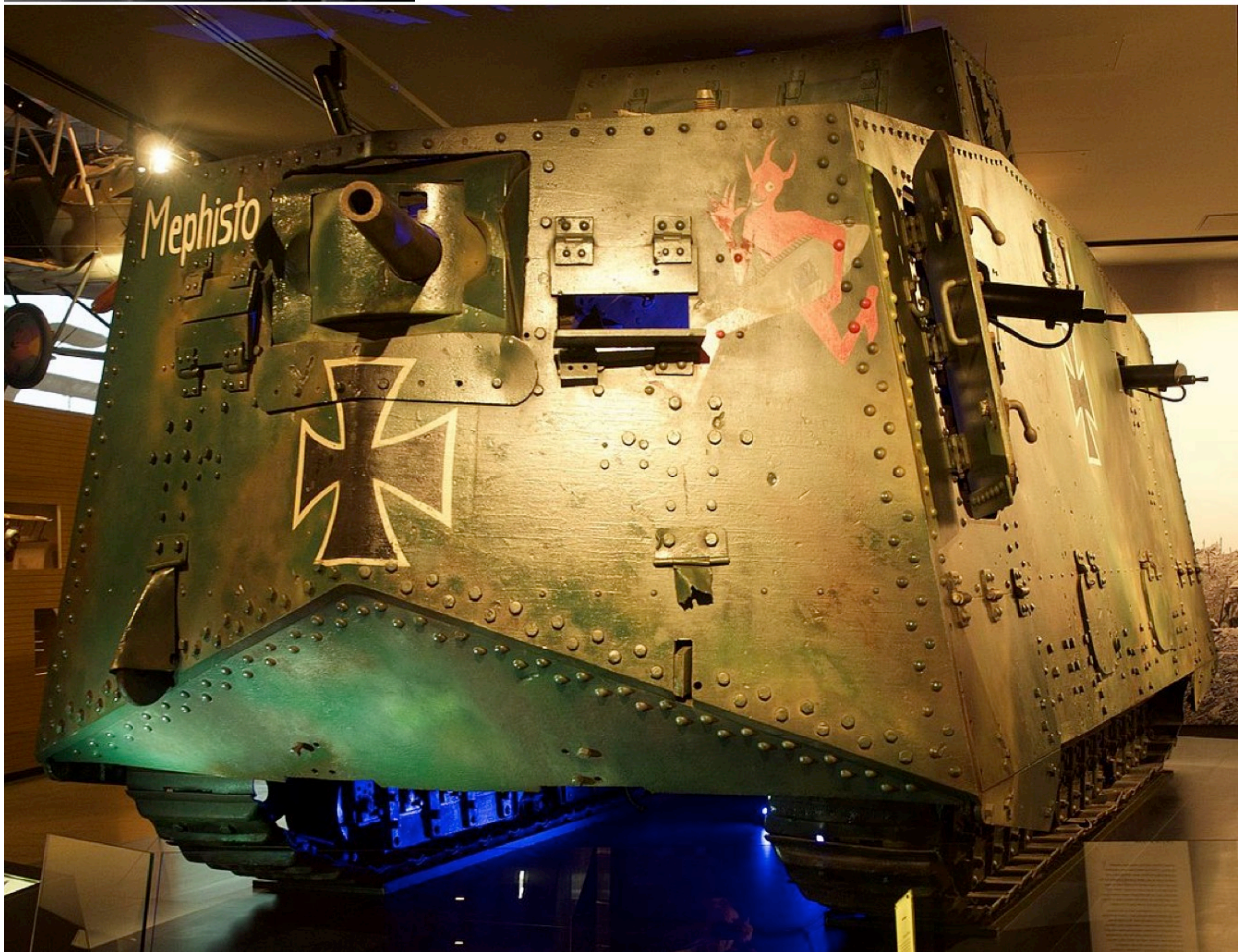


Figure 7.56: Joseph Vollmer developed the first internal-combustion-engine-powered tractor-trailer truck in 1903, then created tanks such as the A7V during World War I.





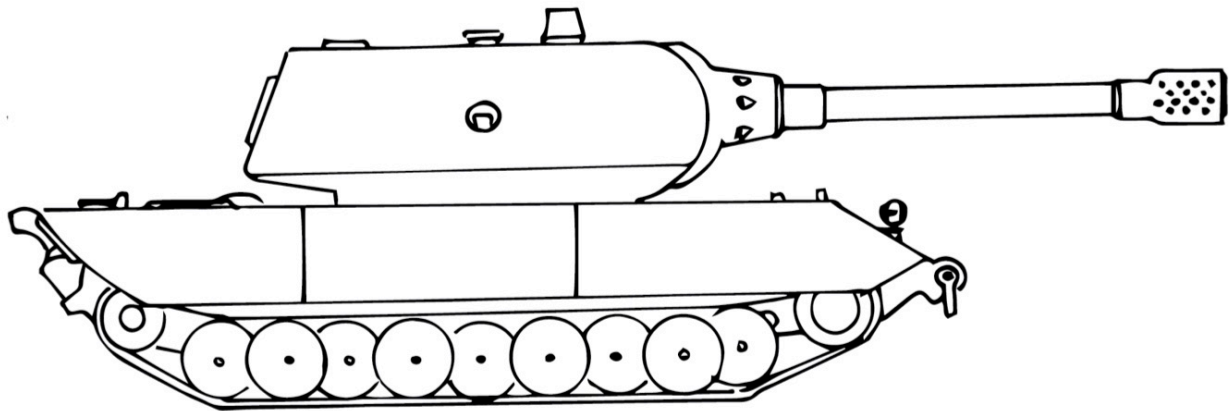
**Porsche  
Tiger I tank  
(1942)**



**Porsche  
Panzer VIII  
Maus tank  
(1944)**

Figure 7.57: Ferdinand Porsche, Karl Rabe, and their team developed advanced tanks such as the Tiger I 57-ton tank and the Panzerkampfwagen VIII Maus prototype 188-ton tank (now in the Kubinka Tank Museum) during World War II.





**Henschel Panzerkampfwagen E-100 tank prototype (1945)**



Figure 7.58: A Henschel Panzerkampfwagen E-100 140-ton tank prototype was taken by British troops at the end of World War II (shown on top of a trailer, without the turret and treads).

**Nicholas Straussler (1891–1966)**  
**Duplex drive (DD) amphibious tanks (1940–1944)**



Dec. 11, 1945.

N. STRAUSSLER

2,390,747

MEANS FOR IMPARTING BUOYANCY TO VEHICLES

Filed March 13, 1942

3 Sheets-Sheet 1

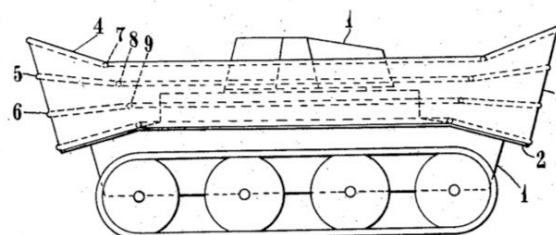


Fig 1

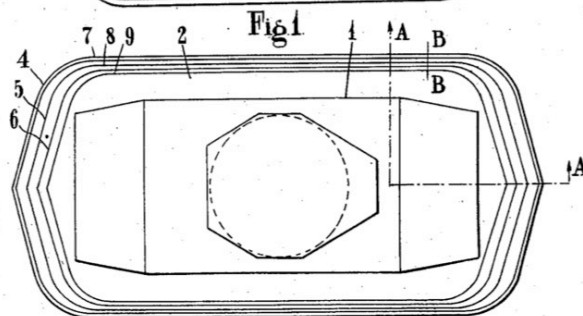


Fig 2

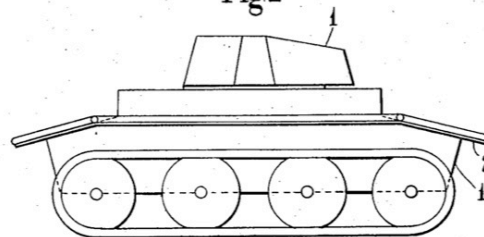


Fig 3



Figure 7.59: Nicholas Straussler emigrated to the United Kingdom and developed the duplex drive (DD) amphibious tanks that were used by Allied forces for the invasion of Normandy.





**Anselm  
Franz  
(1900–1994)**

**Lycoming/Honeywell AGT1500 turboshaft engine for U.S. M1A1 Abrams tank (engine proposed in 1951, first operational in 1966)**



Figure 7.60: Anselm Franz developed the AGT1500 turboshaft engine that is still used in the U.S. M1A1 Abrams tank.



### 7.3.4 Diesel Train Locomotives

German-speaking creators were responsible for adapting Diesel internal combustion engines to locomotives, where they continue to be used worldwide.

In 1912, Rudolf Diesel (German, 1858–1913) and Adolf Klose (German, 1844–1923) developed the first Diesel locomotive, shown in Fig. 7.61. The shaft of a Diesel engine rotates at high speeds and produces relatively small amounts of torque or force, yet a locomotive’s wheels must rotate at relatively low speeds and apply large amounts of torque. Therefore, Diesel and Klose had to build an elaborate gear system to convert the high-speed, low-torque rotation of the engine shaft to low-speed, high-torque rotation of the wheels.

As illustrated in Fig. 7.62, in 1914 Hermann Lemp (Swiss, 1862–1954) developed the Diesel-electric drive for trains. Lemp’s design used the Diesel engine to power an electric generator, then used that electricity to run electric motors connected to the wheels. Lemp’s approach eliminated the need for a complex gearing system, since the electric generator could receive high-speed, low-torque power from the Diesel engine and produce electricity to power low-speed, high-torque electric motors attached to the wheels. In other words, the electric generator essentially took the place of the earlier gearing system. From 1920 onward, Lemp designed a number of Diesel-electric locomotives for the General Electric company in the United States. Diesel-electric locomotives rapidly replaced pure Diesel locomotives and any remaining steam locomotives, and they continue to dominate train systems around the world.

Werner von Siemens (German, 1816–1892) built the first electric train in 1879 and filed a patent application on electric trains in 1884 [Bähr 2016; von Siemens 1895]. See Fig. 6.3. His company built electric trains and systems for cities in Europe and North America.

Alfred Zehden (German, 1876–19??) invented magnetic levitation (maglev) trains in 1902 (p. 3204). Hermann Kemper (German, 1892–1977) patented improved maglev train systems in 1934 (p. 3213). From currently available documentation, it is not clear how far Zehden and Kemper got with actually building and testing maglev train systems, but their designs and principles have guided that technology ever since.

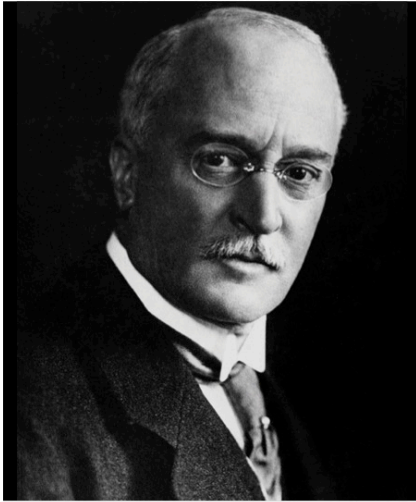
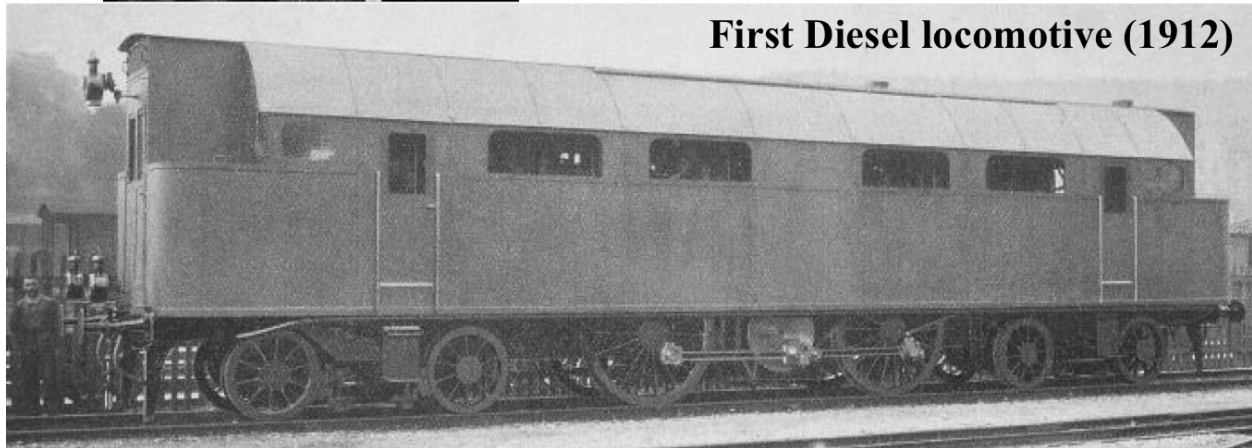
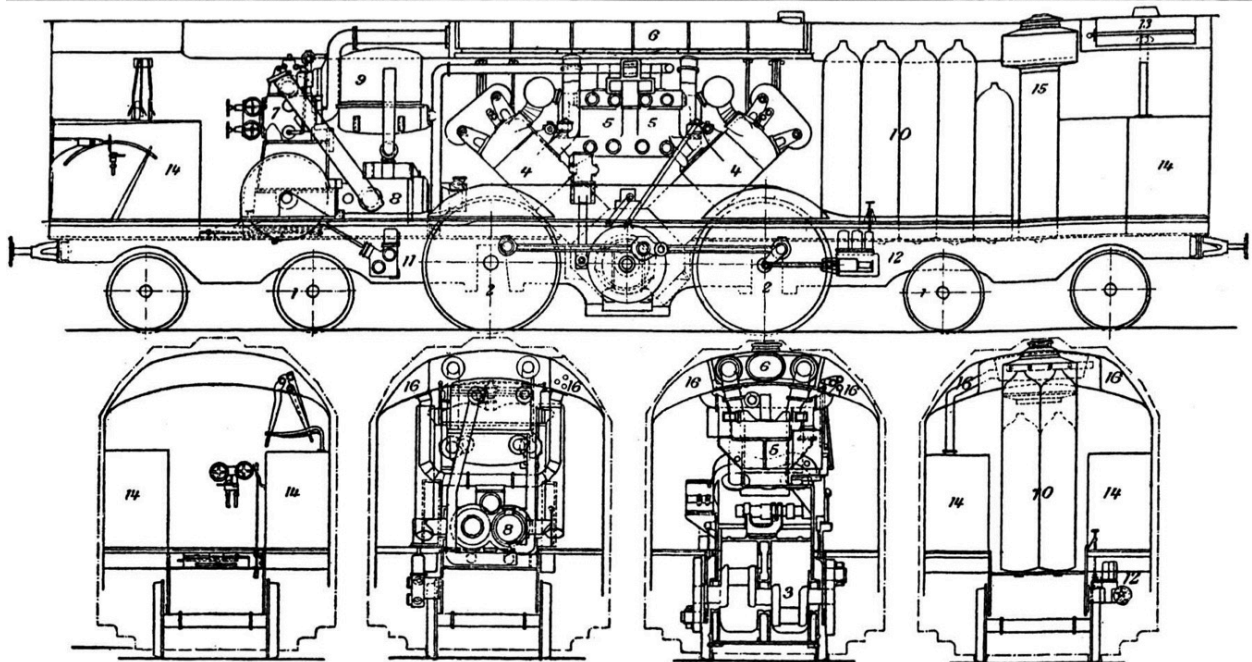
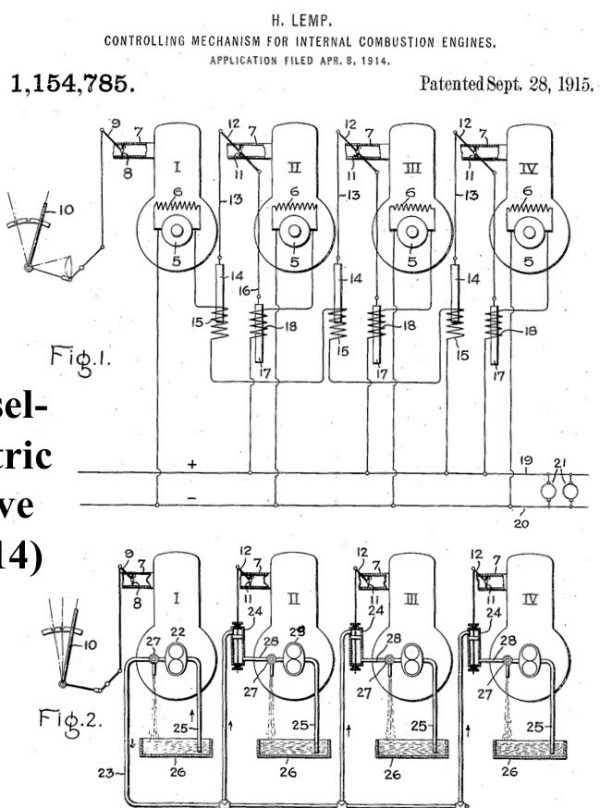
**Rudolf Diesel (1858–1913)****Adolf Klose (1844–1923)****First Diesel locomotive (1912)**

Figure 7.61: Rudolf Diesel and Adolf Klose developed the first Diesel locomotive in 1912.

## Hermann Lemp (1862–1954)



### Diesel- electric drive (1914)

Lemp  
designed  
General  
Electric (GE)  
Diesel-electric  
locomotives  
(1920  
onward)



Figure 7.62: Hermann Lemp developed the Diesel-electric drive in 1914 and designed Diesel-electric locomotives for General Electric from 1920 onward.



## 7.4 Heat Transfer

Heat, or thermal energy, may be transferred from one place to another by several different mechanisms. As illustrated in Fig. 7.63, those mechanisms include:

- (a) Conduction
- (b) Forced convection
- (c) Natural convection
- (d) Condensation and evaporation
- (e) Boiling
- (f) Thermal radiation

For each type of heat transfer, the rate at which thermal energy is transferred depends in fairly complex ways on several different factors, such as the temperature difference, the composition of the materials involved, the surface area, and other variables. In general, heat transfer rates were first measured in a wide range of situations, and then the principles of physics were used to derive suitable equations to explain, extend, and generalize those empirical results. Those equations often involved “dimensionless numbers,” or ratios of several parameters such that the measured dimensions cancel out, leaving only a number whose size governs the rate of heat transfer.

Once the heat transfer mechanisms were properly understood, they exploited to design cooling fins, heat exchangers, and other systems to control and utilize heat transfer. Heat transfer technology has enabled countless applications in the modern world, such as: thermal energy transport in heat engines and refrigerators; cooling of integrated circuit chips, nuclear reactors, and engines; and insulation of everything from thermos bottles to buildings.

Some of the earliest mathematical analyses of heat transfer were conducted by French scientists such as Jean Baptiste Biot (1774–1862) and Joseph Fourier (French, 1768–1830), although they had few successors, probably due to the long-term political turmoil in France. Some British scientists such as Osborne Reynolds (English, 1842–1912) and Thomas Edward Stanton (English, 1865–1931) also made relevant discoveries, yet their numbers were kept small by the relatively limited and focused British support for scientific research.

In contrast, the German-speaking world made a large number of contributions to heat transfer, due to its large-scale, long-term support for research in closely related fields such as internal combustion engines, aircraft engines, rocket engines, nuclear energy, aerodynamics, and other areas. Just a few illustrative examples of German-speaking scientists who carried out measurements and calculations of different modes of heat transfer are shown in Fig. 7.64 and discussed below.

## Heat transfer measurements and calculations

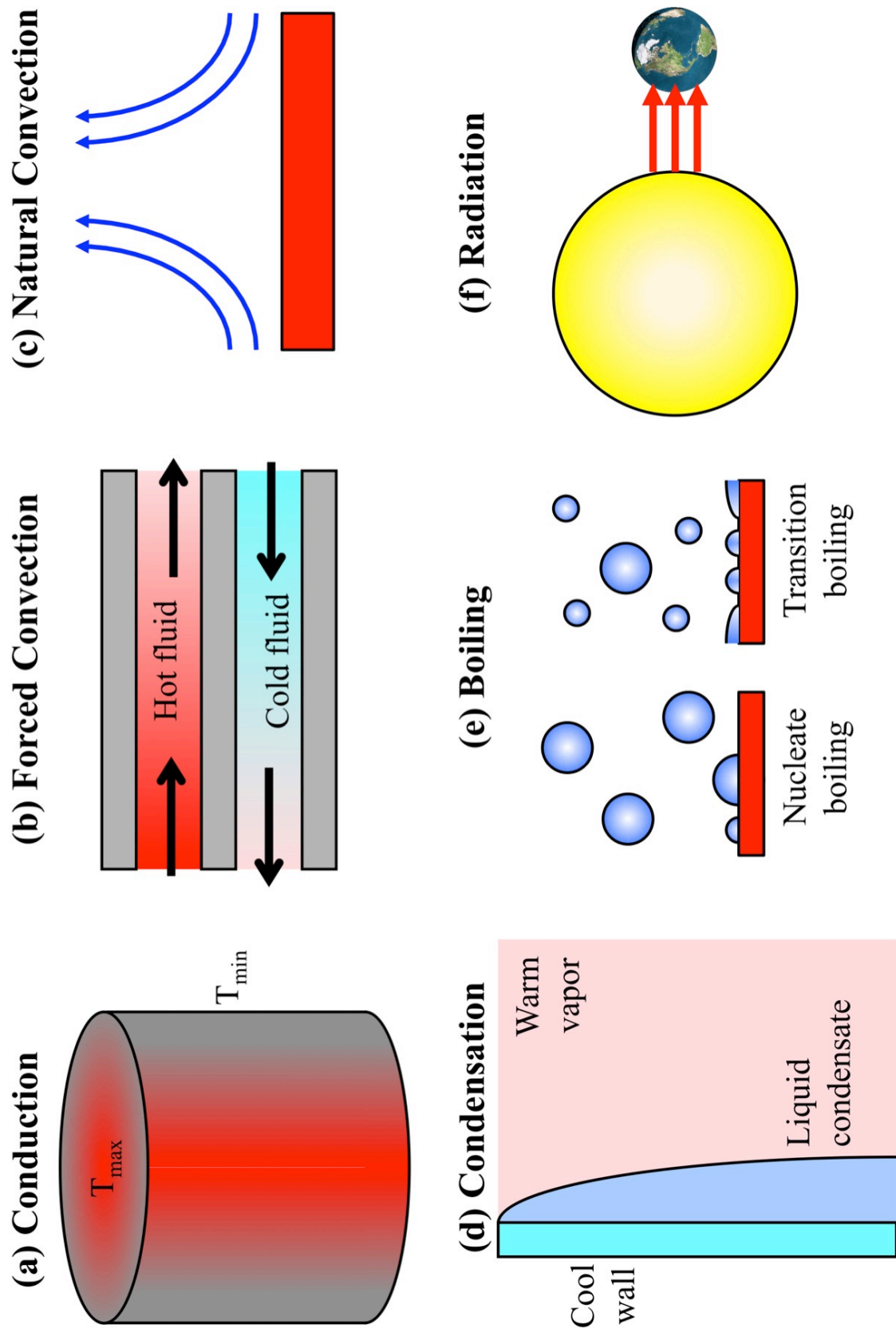


Figure 7.63: Heat, or thermal energy, may be transferred from one place to another by mechanisms such as (a) conduction, (b) forced convection, (c) natural convection, (d) condensation/evaporation, (e) boiling, and (f) thermal radiation.

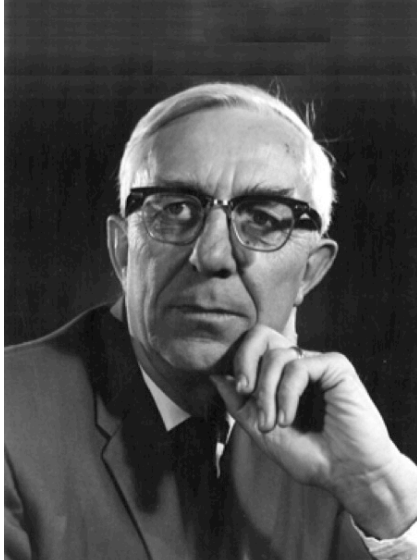
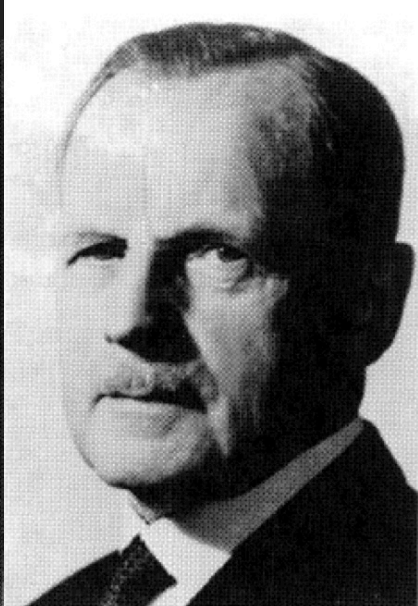
**Heat transfer measurements and calculations****Ernst Eckert**  
(1904–2004)**Leo Graetz**  
(1856–1941)**Franz Grashof**  
(1826–1893)**Max Jakob**  
(1879–1955)**Wilhelm Nusselt**  
(1882–1957)**Ernst Schmidt**  
(1892–1975)

Figure 7.64: Scientists such as Ernst Eckert, Leo Graetz, Franz Grashof, Max Jakob, Wilhelm Nusselt, and Ernst Schmidt carried out measurements and calculations of different modes of heat transfer.



Ernst Eckert (Austrian/German, 1904–2004) studied the fundamental principles of heat transfer and then applied those to jet engines during World War II. After the war, he came to the United States, where he continued his research on heat transfer and its applications. A dimensionless number, the Eckert number, is named in his honor and still widely used in calculating heat transfer dissipation during fluid flow. His obituary provided some details from his life [Jean 2004]:

Ernst R.G. Eckert's 100th birthday party and symposium will continue as planned in September despite the July 8 death of the internationally renowned aeronautical research scientist and University of Minnesota professor emeritus.

The West St. Paul resident was a specialist in heat transfer—the process in which heat moves from one medium to another—and was recognized for exploring new methods of cooling jet turbines so they wouldn't burn up in space.

Eckert's seven decades of research and more than 550 published scientific papers and books significantly contributed to the development of thermodynamics. He developed the "Eckert Number"—a formula used to calculate high-speed heat transfers.

"One of the things my father was proudest of was that he changed the field of thermodynamics," said Karin Winter, one of Eckert's daughters who was visiting from her home in Amherst, Mass. "My father was extremely modest, and he had a lot of grace, so people loved him. He was always forward-looking and positive."

She recalled that when she was a German literature student at Stanford University, mechanical engineering students would ask her to autograph her father's textbooks. Eckert, a native of Prague, Czechoslovakia, (then part of the Austria-Hungary Dual Monarchy), graduated from the German Institute of Technology in Prague in 1927 and received his doctorate in 1931.

"He used to joke with us kids that he changed citizenship several times without ever leaving home," Winter said.

He was a World War II rocket and jet engine scientist at the Aeronautical Research Institute in Braunschweig, Germany, beginning in 1938 and professor at the German Institute of Technology.

Eckert also held a place in history because he was one of more than 200 German scientists the U.S. government invited here after the war in 1945 under "Operation Paperclip." He joined the staff of Wright-Patterson Air Force Base in Dayton, Ohio, to continue his research on jet propulsion. He became a U.S. citizen in 1950.

He joined the University of Minnesota in 1951 and became one of its first Regents' professors in the late 1960s. Later, Eckert became involved in researching how to turn solar energy into electric power.

"He was an excellent teacher," said University of Minnesota Professor Emeritus Emil Pfender, who worked with Eckert for more than 30 years in the mechanical engineering

department. “People really enjoyed his lectures because he really could explain things very well.”

Eckert received several honorary doctorate degrees and awards, including the American Society of Mechanical Engineers’ first Max Jakob medal for outstanding engineering in 1961, and a Fulbright Award in 1962.

Leo Graetz (German, 1856–1941) conducted research in heat conduction, thermodynamics, radiation and radiative heat transfer, frictional heating, and many other areas of physics and engineering. His name remains associated with the Graetz number, a dimensionless number that is helpful in calculating heat transfer in heat exchanger pipes. The *Journal of Heat Transfer* described him as one of the pioneers of heat transfer [<http://www.seas.ucla.edu/jht/pioneers/pioneers.html>]:

Leo Graetz was a German Physicist born at Breslau, Germany on September 26, 1856. He studied Mathematics and Physics at Breslau, Berlin and Strassburg. In 1881, he became the assistant to A. Kundt at Strassburg and in 1883 he went to the University of München where he became a Professor in 1908 and occupied the Second Chair for Physics parallel to Roentgen. His scientific work was first concerned with the fields of heat conduction, radiation, friction and elasticity. After 1890, his work focused upon problems of electromagnetic waves and cathode rays.

Franz Grashof (German, 1826–1893) made major discoveries across several fields in engineering, including heat transfer, fluid mechanics, the strength of materials, and other topics. He is memorialized with the Grashof number, a dimensionless number that is important in calculations of natural convection. The American Council of Learned Societies listed some of his important contributions [ACLS 2000, p. 369]:

Studied and taught at the Gewerbe-Institut in Berlin; director of Office of Weights and Measures. Founding member (1856), editor, and long-time director of the Verein Deutscher Ingenieure (VDI). Later taught at the Polytechnikum in Karlsruhe. Authority on mechanical engineering in its broadest sense. Influenced a generation of engineers by bringing mathematical and scientific considerations to the burgeoning problems of the steam-engine age. Was first to present fundamental equations of theory of elasticity, in a text on strength of materials. Name perpetuated in the dimensionless Grashof number of heat transfer in free-convection flow systems for the transition from laminar to turbulent flow, and the Grashof criterion used in kinematics for establishing whether one link of a four-bar chain can rotate completely.

Max Jakob (German, 1879–1955) worked on many mechanisms and applications of heat transfer over his long career. In 1936, he fled Germany for the United States, where he continued his research for many more years. His name is tied to the Jakob number, a dimensionless number that is extremely useful for calculating heat transfer involving condensation or evaporation. The *Journal of Heat Transfer* explained Jakob’s importance for the field of heat transfer [<http://www.seas.ucla.edu/jht/pioneers/pioneers.html>]:

Max Jakob was a German Physicist, born July 20, 1879, in Ludwigshafen, Germany. He studied Electrical Engineering at the Technical University of Munchen where he

graduated in 1902. He was awarded a Diploma Ingenieur in Applied Physics in 1903, and the degree of Doctor Ingenieur in 1904. From 1903 until 1906, he was an assistant to O. Knoblauch at the Laboratory for Technical Physics and later joined the Physikalisch-Technische Reichsanstalt at Berlin-Charlottenburg in 1910, where he started his career in thermodynamics and heat transfer. He conducted a large amount of important work in these fields, covering such areas as steam and air at high pressure, devices for measuring thermal conductivity, the mechanisms of boiling and condensation, flow in pipes and nozzles and much more. During this time, he wrote over 200 technical papers and was a prolific source of critical reviews, articles and discussions. In 1936, he emigrated to the United States, and began a one-year lecture tour sponsored by ASME. He became a research professor at the Illinois Institute of Technology and a Consultant in Heat Transfer Research for the Armour Research Foundation. In 1942, he founded and became the first director of IIT's Heat Transfer Laboratory. His long years of research resulted in significant contributions to the literature of the profession; nearly 500 books, articles, reviews and discussions have been published bearing his name.

Wilhelm Nusselt (German, 1882–1957) made numerous important discoveries in heat transfer, including several different heat transfer mechanisms and applications. He is remembered with the Nusselt number, the ratio of convective vs. conductive heat transfer. The American Council of Learned Societies summarized his contributions [ACLS 2000, p. 654]:

Studied mechanical engineering at Technischen Hochschulen of Munich and Charlottenburg (Berlin); received doctorate from Munich (1907). Held various teaching and industrial positions until 1925, when he was named to the chair in theoretical mechanics at the Technische Hochschule in Munich (retired 1952). Nusselt was the first significant contributor to the subject of analytical convective heat transfer. In “The Basic Law of Heat Transfer” (1915) he set up the dimensionless functional equations for both natural and forced convection, thus making it possible for experimentalists to generalize limited data; in “The Film Condensation of Steam” (1916) he provided a simple description of the film condensation of any liquid by linearizing the temperature profile and ignoring inertia in the liquid. He later provided an important description of the similarity between heat and mass transfer (1930), and published a book on technical thermodynamics (2 vols.; 1934, 1944).

Ernst Schmidt (German, 1892–1975) worked on conduction, convection, condensation, and radiative heat transfer, discovering important new information on each of those mechanisms. His name remains associated with the Schmidt number, a dimensionless number that makes an analogy between mass transfer and heat transfer. The *Journal of Heat Transfer* lauded his accomplishments [<http://www.seas.ucla.edu/jht/pioneers/pioneers.html>]:

Ernst Schmidt was a German scientist and pioneer in the field of Engineering Thermodynamics, especially in Heat and Mass Transfer. He was born on February 11, 1892 at Vogelsen, near Luneburg, Germany. He studied Civil and Electrical Engineering at Dresden and Munchen and joined the Laboratory for Applied Physics at the Technical University, Munchen, in 1919 (which was then under the direction of Oscar Knoblauch). One of his early research efforts there was a careful measurement of the radiation properties of solids, which caused him to propose and develop the use of aluminum foil as



an effective radiation shield. In 1925, he received a call to come serve as Professor and Director of the Engineering Laboratory at the Technical University in Danzig. Here he published papers on the now well known “Graphical Difference Method for Unsteady Heat Conduction” and on “The Schlieren and Shadow Method” to make thermal boundaries visible and to obtain local heat-transfer coefficients. He was the first to measure the velocity and temperature field in a free convection boundary layer and the large heat-transfer coefficients occurring in droplet condensation. A paper pointing out the analogy between heat and mass transfer caused the dimensionless quantity involved to be called the “Schmidt Number.” In 1937, he became the Director of the Institute for Propulsion of the newly founded Aeronautical Research Establishment at Braunschweig and Professor at the University there. In 1952, Schmidt occupied the Chair for Thermodynamics at the Technical University of München which before him had been held by Nusselt. Being strongly involved in the development of the international steam tables, Schmidt continued his scientific activity after his retirement in 1961 and until his death in 1975. In recognition of his work, he received numerous honors and awards, including the Ludwig Prandtl Ring, the Max Jakob Award and the Grashof Commemorative Medal.

In the German-speaking world, there was an enormous amount of overlap between investigations of the fundamental mechanisms of heat transfer and research on many examples and applications of heat transfer, including:

- High-temperature and high-pressure chemistry (Section 3.2)
- Physical chemistry (Section 3.6)
- High-temperature ceramics (p. 667)
- High-temperature metal alloys (p. 689)
- Heat transfer within the Earth, ocean, atmosphere, and extraterrestrial bodies (Chapter 4)
- Thermal physics (Section 5.5)
- Internal combustion engines (Section 7.3)
- Nuclear engineering (Sections 8.7, 8.8, and 8.9)
- Aerodynamics (Section 9.2)
- Jet engines (Section 9.3)
- Rocket engines (Sections 9.6, 9.7, 9.8, 9.9, and 9.10)

## 7.5 Civil Engineering and Architecture

German-speaking creators made numerous important contributions in the areas of civil engineering and architecture.<sup>5</sup> Only a few illustrative examples are discussed in this section:

- 7.5.1. Stress, strain, and bridge design
- 7.5.2. Autobahn high-speed road system
- 7.5.3. Kitchen design
- 7.5.4. Other creations in civil engineering and architecture

### 7.5.1 Stress, Strain, and Bridge Design

Figure 7.65 shows examples of German-speaking scientists who made measurements and developed mathematical formulas for various types of stress and strain in materials:

- August Wöhler (1819–1914) analyzed the bending or deflection of beams under stress, and also produced curves showing the effects of fatigue or repeated stresses in metals.
- Franz Grashof (German, 1826–1893) wrote a textbook on the strength of materials, developed the fundamental equations of elasticity in materials, and also made important discoveries in heat transfer (pp. 1387, 1389).
- Christian Otto Mohr (German, 1835–1918) created the Mohr’s circle method that is still used to analyze combinations of stresses.
- Heinrich Müller-Breslau (German, 1851–1925) greatly improved the theory of beams and frames, wrote textbooks on the strength of materials and structural mechanics, and designed airship frames and other structures (p. 1645).
- Wilhelm Flügge (German, 1904–1990) developed the theory of stresses and strains in hollow structures such as fuel tanks and aircraft fuselages.

German-speaking experts also applied their knowledge about stress and strain to design larger and better bridges and other structures:

- Wilhelm August Julius Albert (German states, 1787–1846, Fig. 7.66) studied metal fatigue in 1829. In 1834, he invented wire rope or cable and used it in the first construction projects.
- In 1872, Adolf Bleichert (German, 1845–1901, Fig. 7.66) used wire cable to invent the modern system of cable cars for carrying people and cargo. Bleichert and the company he founded went on to build cable car systems around the world.
- John Roebling (German states, 1806–1869, Fig. 7.67) designed many large-scale projects such as the Brooklyn Bridge (which was completed after his death by his oldest son and daughter-in-law).
- Albert Fink (German, 1827–1897, Fig. 7.68) was famous for developing truss bridges.
- Franz Dischinger (German, 1887–1953, Fig. 7.68) created both cable-stayed bridges and prestressed concrete.

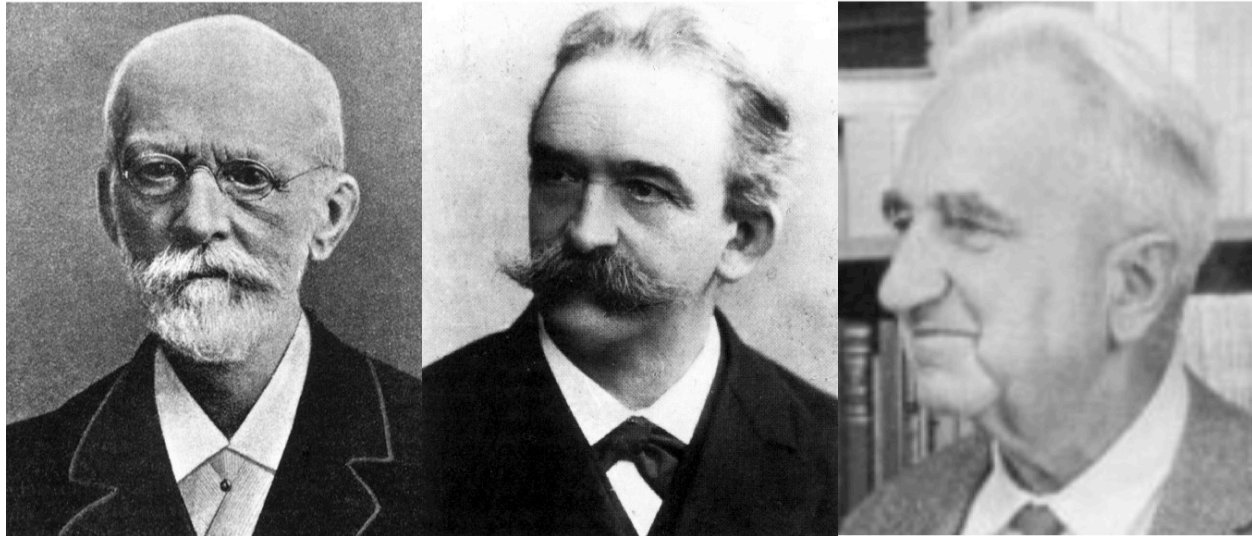
---

<sup>5</sup>Buchheim and Sonnemann 1990; Bunch and Hellemans 2004; Cardwell 1995; Challoner 2009; Gööck 2000; Heckl 2010, 2011; Heßler 2012; Jankowsky 2000; König 2000, 2009; König and Schneider 2007; Ludwig 1974; Lundgreen and Grelon 1994; Radkau 1989, 2016; Technisches Museum Wien 2011; Weitensfelder 2009, 2013.

**August Wöhler**  
(1819–1914)

**Christian Otto Mohr**  
(1835–1918)

**Wilhelm Flügge**  
(1904–1990)



**Measurements and formulas for stress and strain**

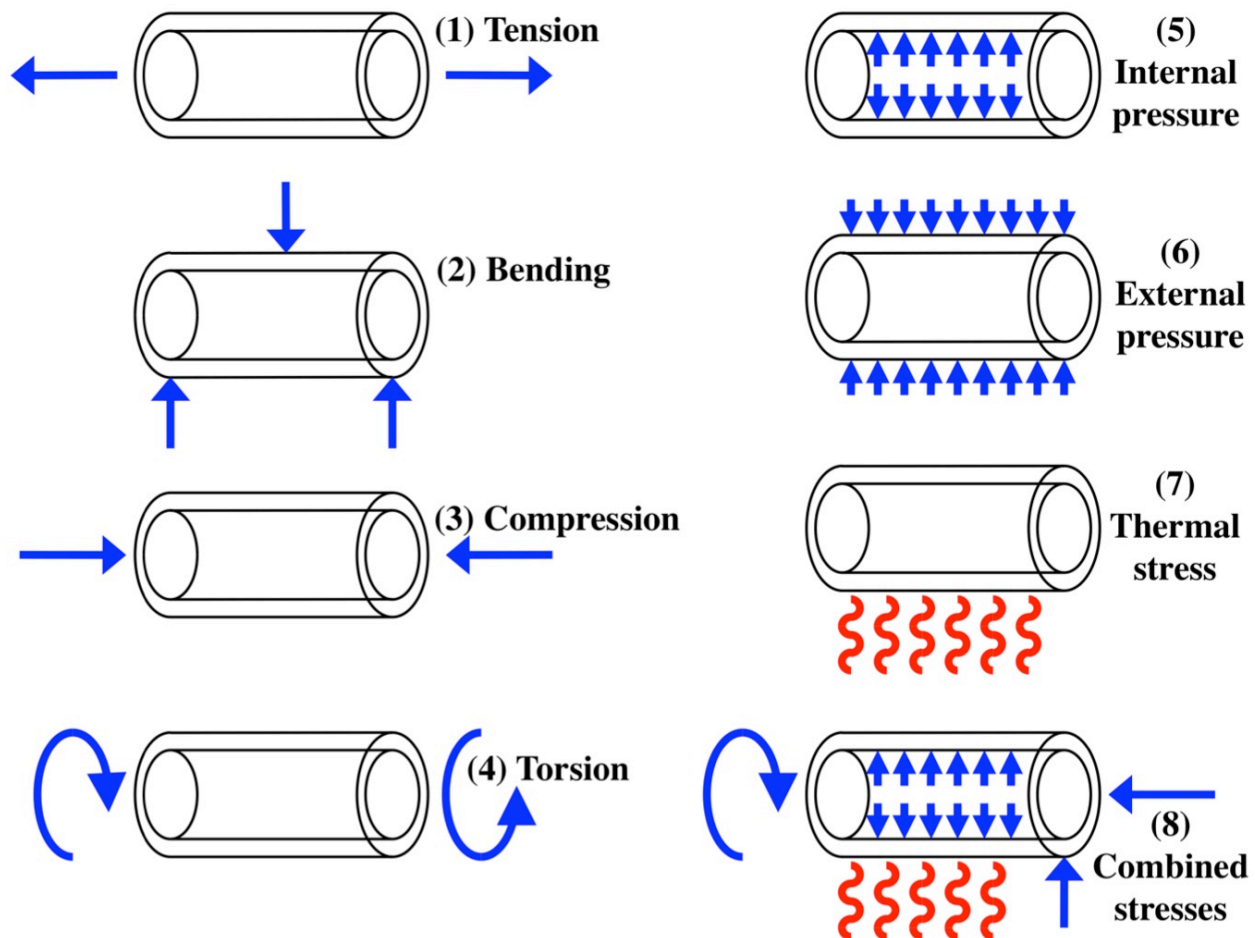
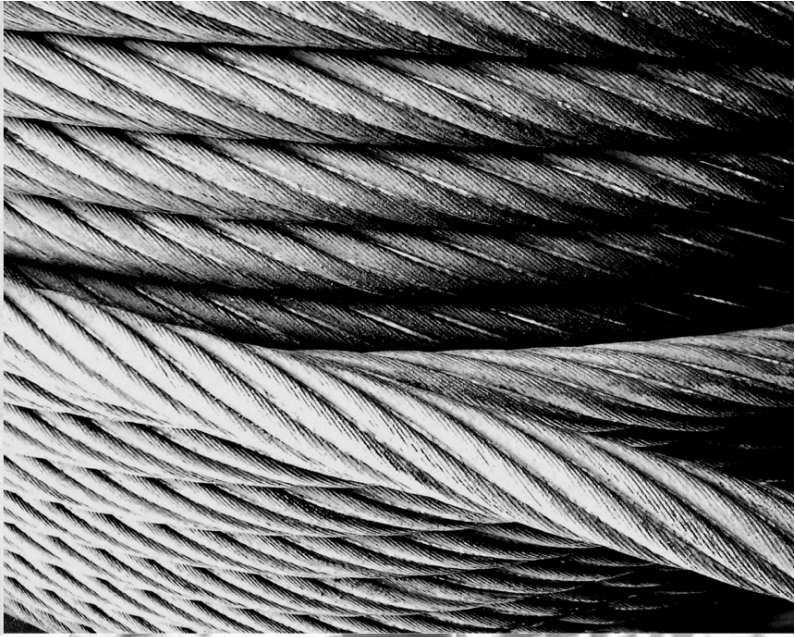


Figure 7.65: August Wöhler, Christian Otto Mohr, and Wilhelm Flügge made measurements and developed mathematical formulas for various types of stress and strain in materials. Franz Grashof (pp. 1387, 1389) and Heinrich Müller-Breslau (p. 1645) also played major roles in this area.





**Wilhelm August Julius  
Albert (1787–1846)**  
studied metal fatigue (1829),  
invented wire rope (1834)

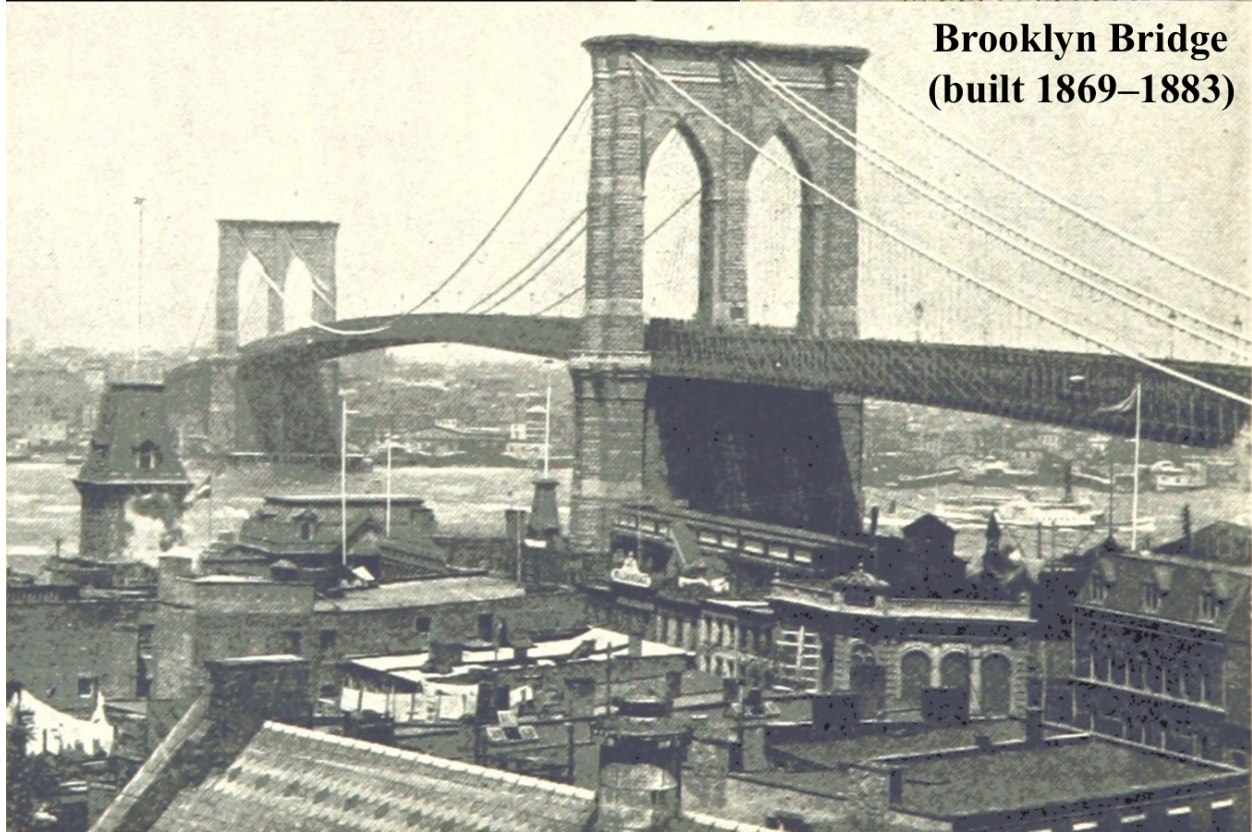
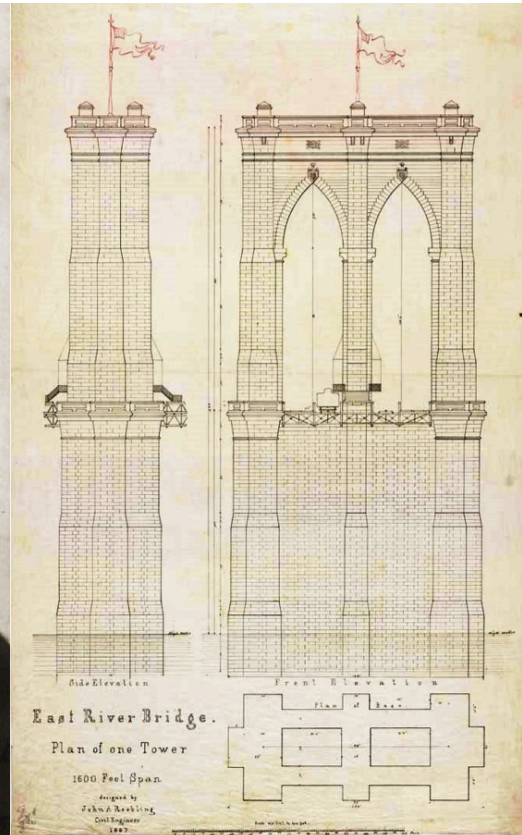
**Adolf Bleichert (1845–1901)**  
developed cable cars (1872)



Bundesarchiv, Bild 102-13609  
Foto: o. Ang. 1. Juni 1932.

Figure 7.66: Wilhelm August Julius Albert studied metal fatigue in 1829, and invented wire rope or cable in 1834. Using wire cable, Adolf Bleichert developed cable cars in 1872.

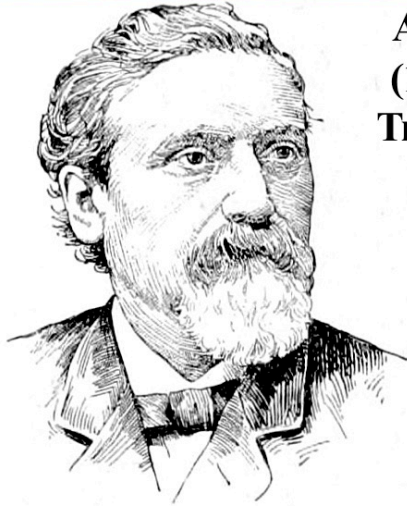
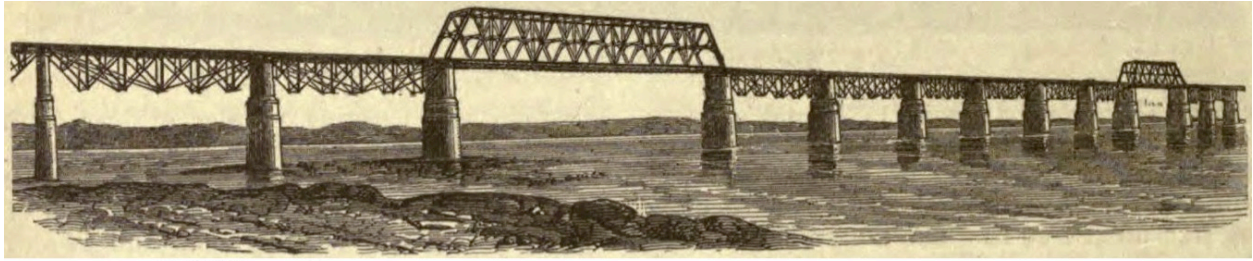
**John Roebling  
(1806–1869)**



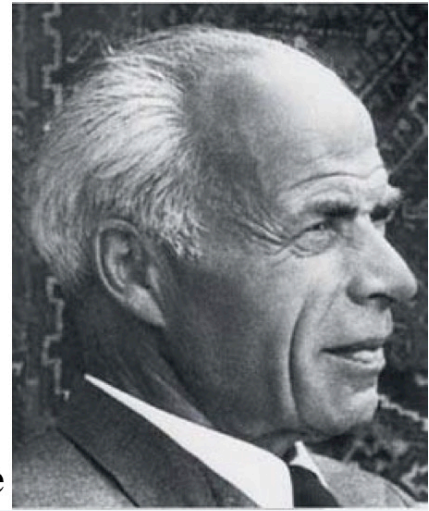
**Brooklyn Bridge  
(built 1869–1883)**

Figure 7.67: John Roebling designed many large-scale projects such as the Brooklyn Bridge, which was completed after his death.





**Albert Fink  
(1827–1897)  
Truss bridges**



**Franz Dischinger  
(1887–1953)  
Cable-stayed bridges  
& prestressed concrete**



Figure 7.68: Albert Fink developed truss bridges, and Franz Dischinger developed both cable-stayed bridges and prestressed concrete.



### 7.5.2 Autobahn High-Speed Road System

Just as the German-speaking world invented internal combustion engines and vehicles to use them, it also created a revolutionary large-scale road system suitable for those vehicles. The German autobahn was designed in the 1920s and built in the 1930s. Figure 7.69 illustrates key aspects of the autobahn's design: one-way multilane roads traveling in each direction, separated by a median, and periodic off- and on-ramps for gas stations and exits. Figure 7.70 also shows examples of early German autobahn bridges, which were necessary both to pass over valleys and rivers and also to divert intersecting roads over or under the autobahn.

The autobahn served as the model for high-speed road networks that were built later in other countries around the world. For example, BIOS 1419, *German Autobahn Bridges* reported an Allied study of the autobahn after World War II:

The Reichsautobahn is essentially a road system for the use of power driven vehicles at considerable speeds, and in order to achieve this end with safety, complete segregation of the traffic in either direction was adopted, and all road intersections on the same level avoided. Pedestrians, cyclists and horse drawn vehicles were forbidden to use these roads, so that no provision was necessary for footpaths, with a consequent reduction of the overall width required.

On the other hand, complete grade separation at intersections made it necessary to build numerous bridges. [...]

In the main, the construction of the autobahnen and their bridges was carried out during the six years, 1934 to 1939. Prior to this, preparatory work and designs had been prepared, while even after 1939, during the war years, a limited amount of work was done.

[For other examples of postwar Allied studies of the autobahn, see BIOS 575; BIOS 917; BIOS 918; FIAT 518].

Dwight Eisenhower was instrumental in copying the autobahn in the United States. In 1919, Eisenhower participated in a military training convoy across the United States and discovered how poorly suited U.S. roads were for automobiles at that time. During World War II, Eisenhower led U.S. forces into Germany and realized how useful the autobahn was. In the 1950s, Eisenhower became the U.S. president and successfully lobbied for the United States to begin construction of an autobahn-like system of interstate roads. U.S. highway historian Richard Weingroff explained [Weingroff 2003]:

Although the 1919 convoy shaped Eisenhower's views, his perspective would be supplemented years later by his observations of the German autobahn network of freeways.

Construction of the first segment of the autobahn began in 1929 and was dedicated on August 6, 1932. When Adolf Hitler assumed power as Chancellor of the Third Reich in 1933, he took over the program, claiming it for his own. The 23-kilometer (14-mile) expressway between Frankfurt and Darmstadt, which opened on May 19, 1935, was the

first section completed under Hitler. By December 1941, when wartime needs brought construction to a halt, Germany had completed 3,864 kilometers (2,400 miles), with another 2,496 kilometers (1,550 miles) under construction.

From the outset of World War II in Europe, the autobahn proved to be a key asset to Germany. The German blitzkrieg (“lightning war”), which involved massive coordinated air and ground attacks to stun opponents, was a key to the German defeat of Poland in 1939 and Belgium, Luxembourg, and the Netherlands in 1940; and the advance to within 480 kilometers (300 miles) of Moscow in 1941. The highway network also enhanced Germany’s ability to fight on two fronts—Europe in the west, the Soviet Union in the east. [...]

In the immediate aftermath of the war, Eisenhower was the military head of occupied Germany. Writer Phil Patton pointed out in *Open Road* that in this capacity, “Eisenhower oversaw the ‘debriefing’ of the Reich, the creation of a series of reports that include close study of the Autobahns.”

Like so many American highway engineers and government officials who had visited Germany during the 1930s, Eisenhower had been impressed by the autobahn. Years later, he would explain that “after seeing the autobahns of modern Germany and knowing the asset those highways were to the Germans, I decided, as President, to put an emphasis on this kind of road building. ... The old [1919] convoy had started me thinking about good, two-lane highways, but Germany had made me see the wisdom of broader ribbons across the land.”

Fritz Todt (German, 1891–1942) established the Organisation Todt in 1933 and ran it until his death in a mysterious plane crash in 1942 (likely an assassination by his political rivals or by Allied agents). Organisation Todt designed and built massive government civil engineering projects, somewhat like the U.S. Army Corps of Engineers (Fig. 7.71).

After Fritz Todt’s death, formal control of Organisation Todt was granted to Albert Speer. However, direct management of Organisation Todt was carried out by Todt’s former deputy, Franz Xaver Dorsch (German, 1899–1986).

Fritz Todt, Franz Xaver Dorsch, and the rest of Organisation Todt built the autobahn in the 1930s. During World War II, they built the heavily fortified Atlantic Wall along the entire western coast of German-controlled territory, as well as the similarly fortified Siegfried Line or Westwall along the entire western border of Germany itself.

After the war, Dorsch continued to work on a wide range of projects in West Germany, and also consulted for the United States.

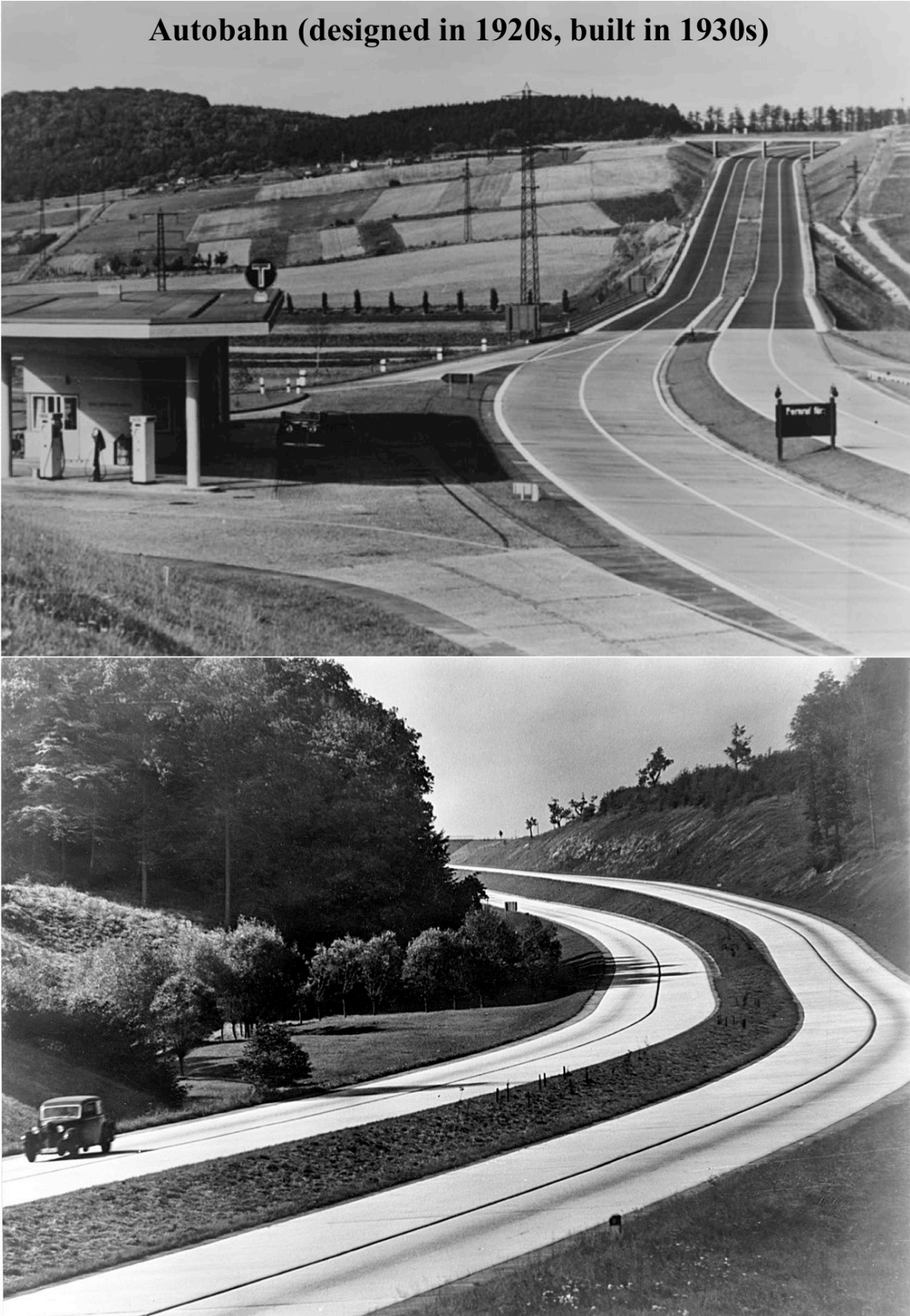


Figure 7.69: The German autobahn was designed in the 1920s and built in the 1930s.



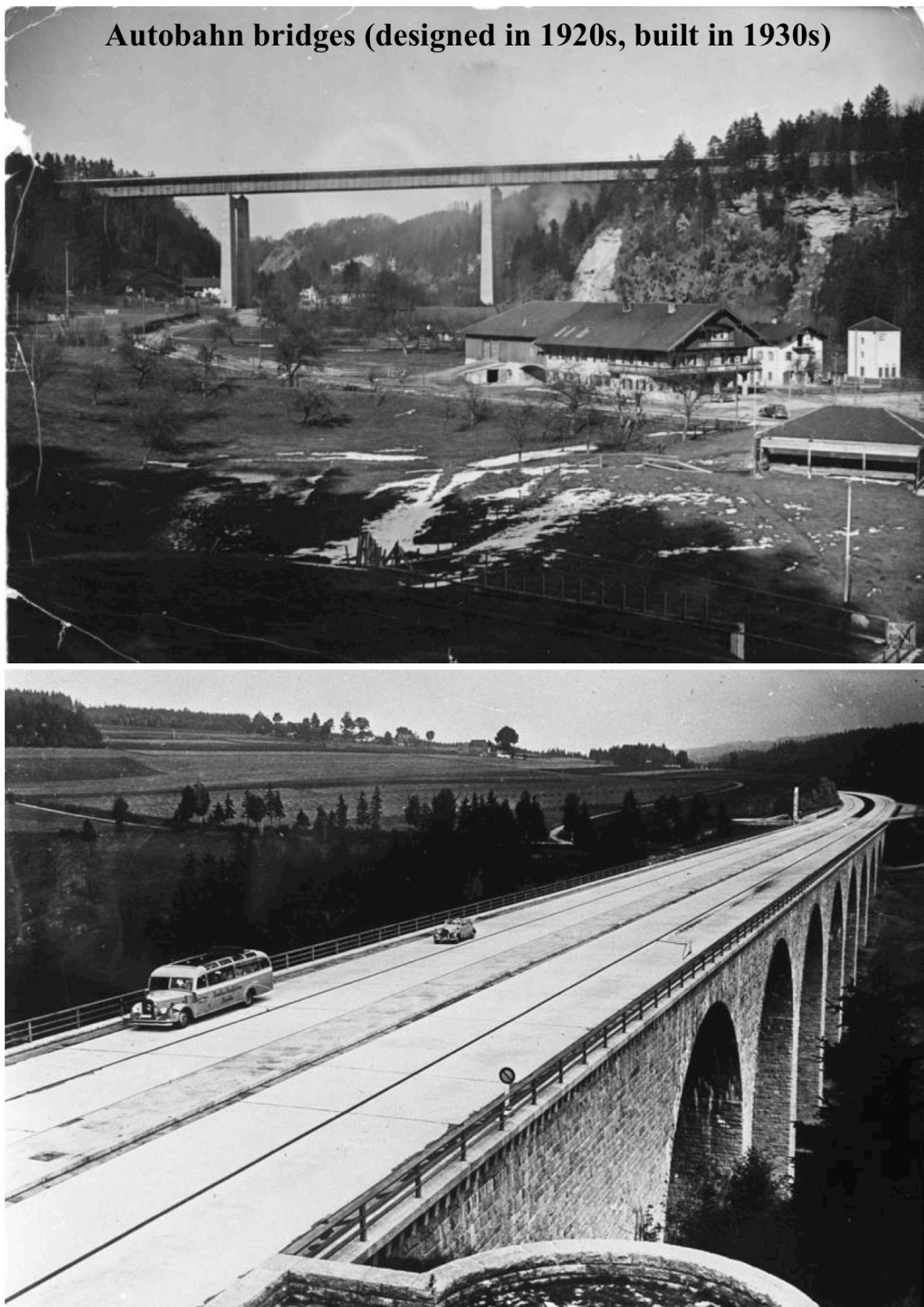


Figure 7.70: Examples of early German autobahn bridges.



**Organisation Todt  
(Autobahn,  
Atlantic Wall,  
Siegfried Line,  
etc.)**

**Fritz  
Todt  
(1891–  
1942)**



**Franz  
Xaver  
Dorsch  
(1899–  
1986)**

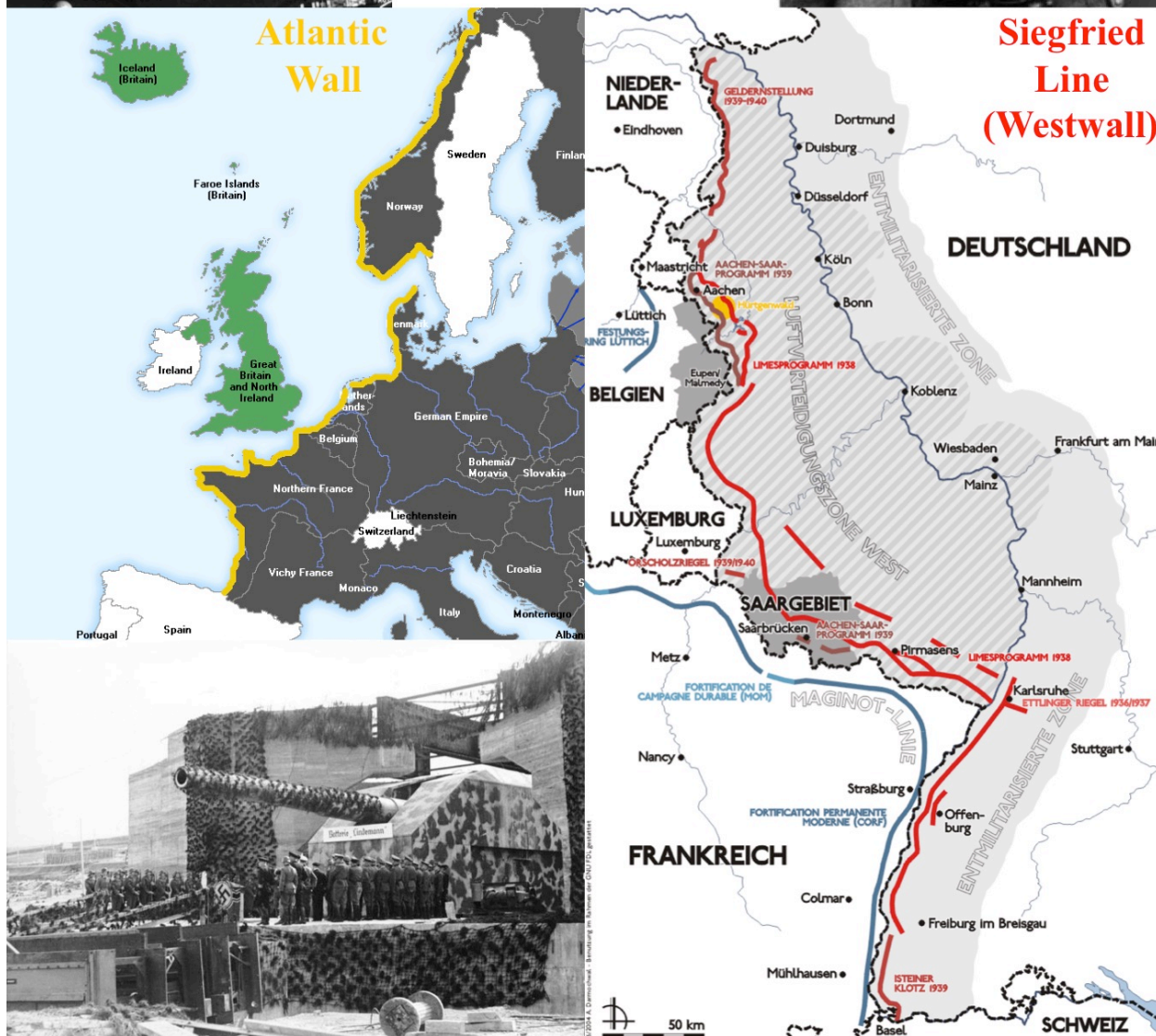


Figure 7.71: Fritz Todt and Franz Xaver Dorsch ran the Organisation Todt, which carried out massive government engineering projects 1933–1945, including the autobahn, Atlantic Wall, Siegfried Line (Westwall), etc. Dorsch continued to work in West Germany after the war.

### 7.5.3 Kitchen Design

Early kitchens had typically either been dedicated rooms staffed by servants in affluent households, or improvised tools gathered around a heating stove in more common households. Margarete Schütte-Lihotzky (Austrian, 1897–2000, Fig. 7.72) revolutionized the concept of the kitchen by designing a separate, standardized, small room that almost every household could use. By 1926, she created the “Frankfurt Kitchen,” which ultimately became the standard kitchen design for apartments and small or medium houses worldwide. (The Frankfurt Kitchen was later adopted and heavily promoted by designers in Sweden, and thus was often incorrectly attributed as the “Swedish Kitchen.”) Sarah Archer, an expert on the history of kitchens, described the importance of Schütte-Lihotzky’s design [Archer 2019]:

Margarete Schütte-Lihotzky (1897–2000) was the first Austrian woman ever to qualify as an architect. Following World War I, she was tasked with the design of standard kitchens for a new housing project by city planner and architect Ernst May. The Great War left rubble and a desperate housing shortage in its wake, but it also opened the way for new ideas and new designs. [...]

Schütte-Lihotzky conceived of the Frankfurt Kitchen as a separate room in each apartment, which was a design choice that had previously applied only to the cavernous kitchens that served great houses. [...]

The Frankfurt Kitchen featured an electric stove, a window over the sink, and lots of ingenious built-in storage including custom aluminum bins with a spout at one end. These bins could be used to store rice, sugar, or flour, then pulled out and used to pour the ingredients into a mixing bowl. The kitchen lacked a refrigerator, but in almost every other way, it was thoroughly modern. There was no clunky cast-iron stove, and no mismatched pieces of wooden furniture that had been drafted into kitchen duty. [...]

Margarete Schütte-Lihotzky introduced design ideals that still hold sway over our living spaces. Recognition for her design spread slowly but steadily. [...]

But in 1927, three different versions of the design were shown at a major Frankfurt exhibition. In the ’30s, it was written up in the German, English, and French press, and attracted the attention of France’s housing minister, who decided he wanted to commission 260,000 units inspired by its design. [...]

While it transformed kitchen design in the 20th century, in certain ways the Frankfurt Kitchen lent more inspiration to new suburban homes than it did to their urban counterparts. This is partly because there was much more new construction in American suburbs following World War II, while large cities tended to be comprised mostly of renters who had to accept their kitchens as they were. The Frankfurt ideals of rational design, optimal work surfaces, color, and smart storage both took shape and grew in size once they took root in suburban ranch homes.





**Margarete  
Schütte-Lihotzky  
(1897–2000)**

**“Frankfurt kitchen,”  
a separate, equipped  
room designed for  
apartments and  
houses (1926)**



Figure 7.72: Margarete Schütte-Lihotzky created the standard “Frankfurt kitchen” design in 1926.

#### 7.5.4 Other Creations in Civil Engineering and Architecture

Rudolf Virchow (German, 1821–1902, Fig. 2.4), Max Joseph von Pettenkofer (German, 1818–1901), James Hobrecht (German, 1825–1902), and Karl Imhoff (German, 1876–1965) designed sewage collection and treatment systems that revolutionized sanitation and health, and that were ultimately used worldwide. See Fig. 7.73.

Max Giese (German, 1879–1935) and Fritz Hell (German?, 18??–19??) invented the concrete pump in 1927; see Fig. 7.74. Jacob Kweimn (Dutch, 18??–19??) developed an improved concrete pump in 1932. The ability to pump liquid concrete completely transformed modern construction methods.

Philip Deidesheimer (German, 1832–1916) studied at the Freiberg University of Mining and moved to the United States in 1852. He invented (or possibly brought from Germany) the approach known as square-set timbering, which uses a sturdy wooden framework to support large three-dimensional cavities in mining (Fig. 7.75). No later than 1860, Deidesheimer was using square-set timbering in mines in the United States.

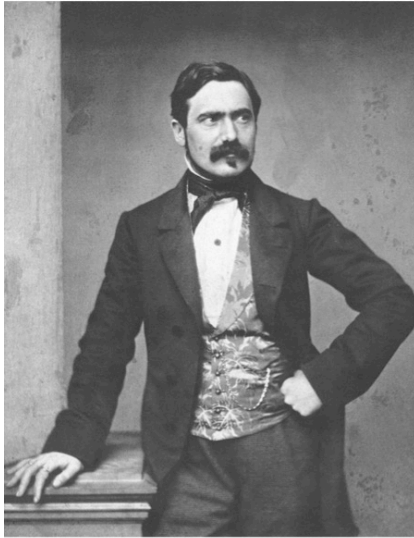
In 1887, Ernst Hubbard (Austrian?, 18??–19??) conducted the first experiments trying to develop useful particle board [Hubbard 1887]. In 1932, Max Himmelheber (German, 1904–2000) and Alfred Schmid (German, 1899–1968) perfected and patented particle board and machines to produce it [Sauer 2016]. The production and use of particle board spread throughout the German-speaking world during World War II and was transferred to other countries after the war. See Fig. 7.76.

Walter Gropius (German, 1883–1969) and Ludwig Mies, also known as Ludwig Mies van der Rohe (German, 1886–1969), created Bauhaus architecture and helped to create the International Style of architecture (Fig. 7.77).

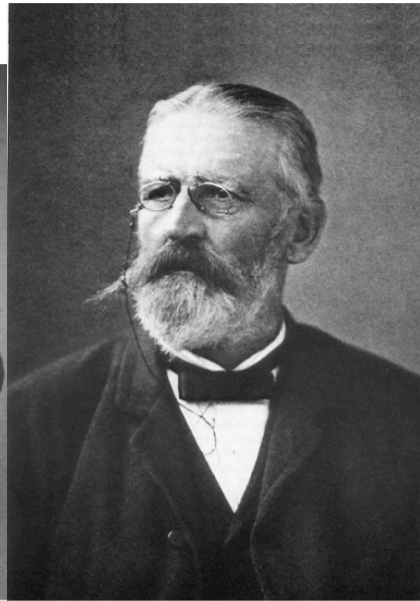
Artur Fischer (German, 1919–2016, Fig. 7.77) invented split plastic wall plugs, Fischertechnik construction toys, and the synchronized photo flash.

Karl Fiebinger (Austrian, 1913–2014, Fig. 7.77) developed revolutionary methods that made it possible to create enormous, fully equipped, bomb-proof underground installations; he worked for Germany during World War II and for the United States after the war.

**Max Joseph  
von Pettenkofer  
(1818–1901)**



**James Hobrecht  
(1825–1902)**



**Karl Imhoff  
(1876–1965)**



### Sewage collection and treatment systems

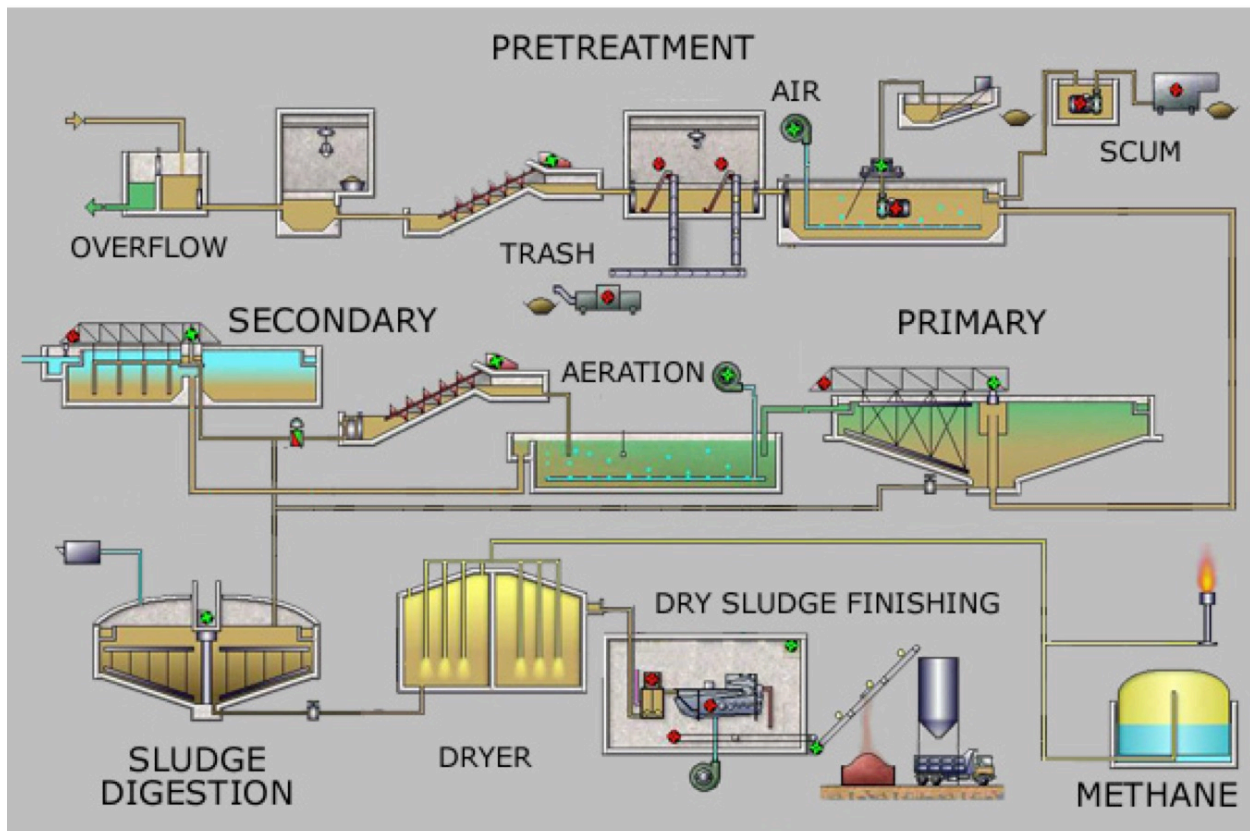


Figure 7.73: Rudolf Virchow (Fig. 2.4), Max Joseph von Pettenkofer, James Hobrecht, and Karl Imhoff designed sewage collection and treatment systems that were ultimately used worldwide.



**Max Giese**  
(1879–1935)

**Fritz Hell**  
(18??–19??)

**Jacob Kweimn**  
(18??–19??)

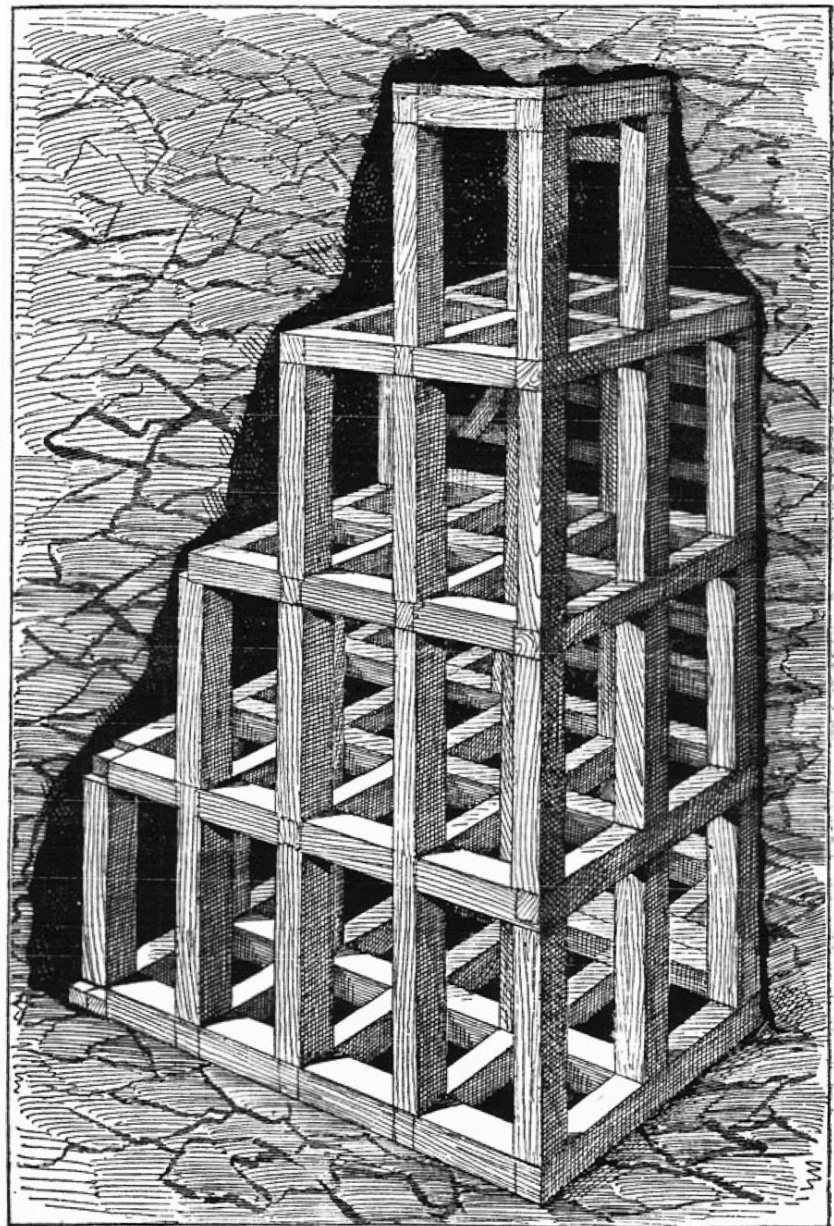


### Concrete pump (1927)



Figure 7.74: Max Giese, Fritz Hell, and Jacob Kweimn invented concrete pumps.

**Philip Deidesheimer  
(1832–1916)**



**Square set  
timbering  
for large  
three-dimensional  
cavities in mining  
(1860 or earlier)**

Figure 7.75: No later than 1860, Philip Deidesheimer created square set timbering to support large three-dimensional cavities in mining.



**Ernst Hubbard**  
(18??–19??)  
First experiments with  
particle board (1887)

**Alfred Schmid**  
(1899–1968)

**Max Himmelheber**  
(1904–2000)



Himmelheber and Schmid perfected particle board (1932)

Nr. 182058

Klasse 41

SCHWEIZERISCHE EIDGENOSSENSCHAFT

EIDGEN. AMT FÜR



GEISTIGES EIGENTUM

PATENTSCHRIFT

Veröffentlicht am 1. April 1936



Gesuch eingereicht: 11. Juli 1932, 18 Uhr. — Patent eingetragen: 31. Januar 1936.

HAUPTPATENT

Prof. Dr. Alfred SCHMID, Berlin-Dahlem, und  
Dipl. Ing. Max HIMMELHEBER, Karlsruhe (Deutschland).

Holzähnliche Masse und Verfahren zu deren Herstellung.

Gegenstand vorliegender Erfindung ist ein holzähnliches Produkt, sowie ein Verfahren zu dessen Herstellung.

Erfindungsgemäße holzähnliche Massen besitzen dem natürlichen Holz gegenüber infolge ungerichteter Lagerung den Vorteil völlig homogener Struktur, sind im übrigen aber in allen Eigenschaften, insbesondere Gewicht, Härte, Bearbeitbarkeit usw. dem Holz weitgehend vergleichbar. Es handelt sich sozusagen um ein homogenisiertes Holz, das alle guten Eigenschaften des Naturholzes aufweist, zum Teil sogar wesentlich verbessert, dabei aber alle jene Nachteile vermeidet, welche die Holzverarbeitung von jeher so schwierig gemacht haben. Das neue Produkt ist dem Naturholz überall dort überlegen, wo dessen gerichtete Faserstruktur zu starken Formänderungen unter atmosphärischen Einflüssen Anlaß gibt, also namentlich im gesamten Anwendungsgebiet des sogenannten Sperrholzes, da Quellung und Schrumpfung, sofern sie überhaupt noch

auftreten, was sich nach der speziellen Herstellungsweise richtet, infolge der homogenen Struktur niemals in einer Richtung bevorzugt wirken können. Nicht zuletzt bietet das Verfahren zur Herstellung dieses „Homogenholzes“ den außerordentlichen Vorteil, das Produkt nach Form und Charakter in den denkbar weitesten Grenzen variieren zu können. Man hat es in der Hand, feinfaserige oder grobfaserige, spezifisch leichte oder dichte Stücke von fast beliebigem Härtegrad und in jeder Form herzustellen.

Es ist verschiedentlich versucht worden, aus Faserstoffen, wie Holzschliff, Zellulose, Stroh und Baumwolle usw. holzartige Produkte herzustellen, die als Holzersatz dienen sollen. Neben dem einfachen Zusammendrücken der genannten Substanzen hat man vor allem durch Verfilzung der Faserstoffe dieses Ziel zu erreichen versucht. Dabei sei mit Verfilzung jene eigentümliche Verbindung von Fasern bezeichnet, die dadurch zustande kommt, daß die zunächst in Wasser

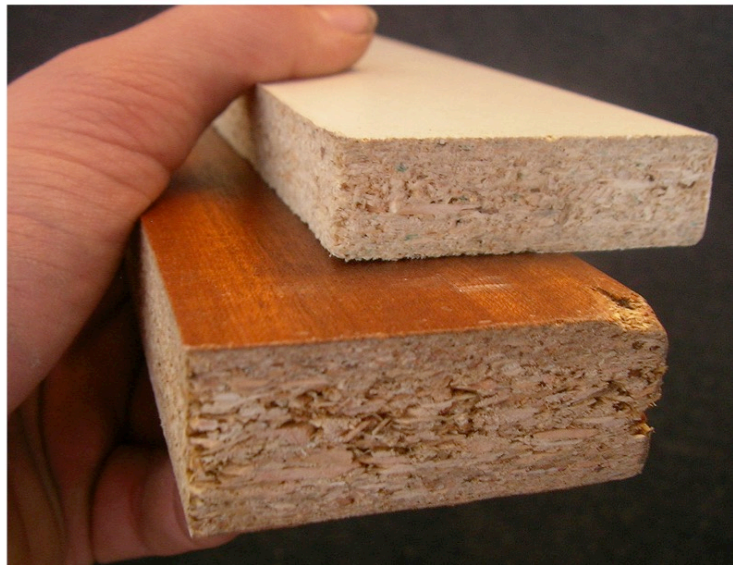


Figure 7.76: Ernst Hubbard conducted the first experiments with particle board in 1887. Max Himmelheber and Alfred Schmid perfected particle board in 1932.



**Other civil engineering and architecture**

**Walter Gropius (1883–1969)**

**Bauhaus architecture**



**Ludwig Mies (1886–1969)**

**Bauhaus architecture**



**Artur Fischer (1919–2016)**

**Split plastic wall plug,**

**Fischertechnik**

**construction toys**

**Karl Fiebinger (1913–2014)**

**Underground installations**



Figure 7.77: Walter Gropius and Ludwig Mies (also known as Ludwig Mies van der Rohe) created Bauhaus architecture and helped to create the International Style of architecture. Artur Fischer invented split plastic wall plugs and Fischertechnik construction toys. Karl Fiebinger designed huge, sophisticated underground installations in wartime Germany and the postwar United States.

## 7.6 Projectile Weapons

German-speaking creators made many important innovations regarding projectile weapons, including<sup>6</sup>:

7.6.1. Guns

7.6.2. Artillery

7.6.3. Shaped-charge anti-tank weapons

7.6.4. Electromagnetic railguns

7.6.5. Flamethrowers

### 7.6.1 Guns

Gaspard Kollner (Austrian, 14??–15??) and Augustus Kotter (Nuremberg, 14??–15??) are credited with inventing rifled gun barrels around 1498–1520. See Fig. 7.78.

Around 1580–1597, Hans Stopler (Nuremberg, 15??–16??) was the first or one of the first gunsmiths to use a revolving section for multiple bullets, shown in Fig. 7.79.

Johann Nikolaus von Dreyse (Thuringia, 1787–1867) invented the bolt-action rifle in 1824. His Dreyse Zündnadelgewehr bolt-action rifle was mass-produced from 1840 onward (Fig. 7.80).

Building upon von Dreyse's work, the brothers Peter Paul Mauser (German, 1838–1914) and Wilhelm Mauser (German, 1834–1882) created the Gewehr 71 bolt-action rifle in 1871. The Mauser company later developed improved versions, including the Gewehr 98 (1898) and Karabiner 98 kurz (1935), as well as the scaled-up Tankgewehr 18 (1918), which was the first anti-tank rifle. See Fig. 7.81.

As shown in Fig. 7.82, Hugo Borchardt (German, 1844–1924) developed the world's first self-loading, semi-automatic pistol, the Borchardt C93, in 1893. Georg Luger (Austrian, 1849–1923) improved upon that design to create the Luger semi-automatic pistol in 1900.

The German [?] brothers Fidel (18??–19??), Friedrich (18??–19??), and Josef Feederle (18??–19??) developed a different semi-automatic pistol design, the Mauser C96, in 1896; see Fig. 7.83.

---

<sup>6</sup>For coverage of different aspects of this area, see especially: Bishop 2014; Bull 2004; DK 2014; Echle 1979; Engelmann and Scheibert 1974; Gander and Chamberlain 1979; Götz 1990; Hogg 1997, 1999, 2001; Jäger 2001; Klein 1977; Ortner 2007; Romanych and Rupp 2013; Senich 1982, 1987; Taube 1979, 1981; Wictor 2007; Wollert et al. 2008; Zaloga and Dennis 2016.

Based on the earlier Luger design, Fritz Walther (German, 18??–19??) created the more advanced Walther PP in 1929 and Walther P 38 in 1938. See Fig. 7.84. Many modern handguns still use the same designs and features as those guns.

As shown in Fig. 7.85, Theodor Bergmann (German, 1850–1931) and Louis Schmeisser (German, 1848–1917) developed the Maschinengewehr MG 15, an early machine gun, in 1915. Bergmann and one of Louis Schmeisser’s sons, Hugo Schmeisser (German, 1884–1953), then developed the Maschinenpistole MP 18, the first practical submachine gun, in 1918. Louis Schmeisser’s other son, Hans Schmeisser (German, 18??–19??), also continued to develop and produce various gun designs.

Modern machine gun designs evolved in the German-speaking world:

- Louis Stange (German, 1888–1971, Fig. 7.86) created the Maschinengewehr MG 30 machine gun in 1930.
- Heinrich Vollmer (German, 1885–1961, Fig. 7.87) developed Stange’s design into the first general-purpose machine gun, the MG 34, in 1934.
- Based directly on the work of Stange and Vollmer, Werner Gruner (German, 1904–1995, Fig. 7.88) produced a further improved version, the MG 42, in 1942.

These German machine gun designs were widely copied and became the direct ancestors of later machine guns worldwide.

Similarly, modern assault rifles (multipurpose handheld weapons capable of acting as anything from single-shot rifles to fully automatic machine guns) were invented in the German-speaking world. Hugo Schmeisser created the Sturmgewehr StG 44 selective-fire assault rifle in 1944, as shown in Fig. 7.89. Based on Schmeisser’s work, Wilhelm Stähle (German, 1901–1974) and Ludwig Vorgrimler (German, 1912–1983) developed an improved version, the Sturmgewehr StG 45, in 1945; see Fig. 7.90. These weapon designs were copied worldwide and gave rise to modern assault rifles such as the AK-47 and M16. In fact, Hugo Schmeisser, Werner Gruner, and other German gun manufacturers were taken to Russia to design guns after the war. Many German gun designers were also interrogated by or went to work for other Allied countries after the war.

As shown in Fig. 7.91, the Krummlauf (curved barrel) modified Sturmgewehr 44, produced in 1944, could shoot around corners. It was equipped with a periscope for seeing around corners as well. Krummlauf rifles were also installed in tank ports to defend the exterior of tanks from close attackers.

In the German-speaking world, innovations in gun design were greatly aided by parallel innovations in optics (see for example Section 6.9) for sighting scopes and by the development of revolutionary infrared imaging or night vision technologies (Section 6.6).



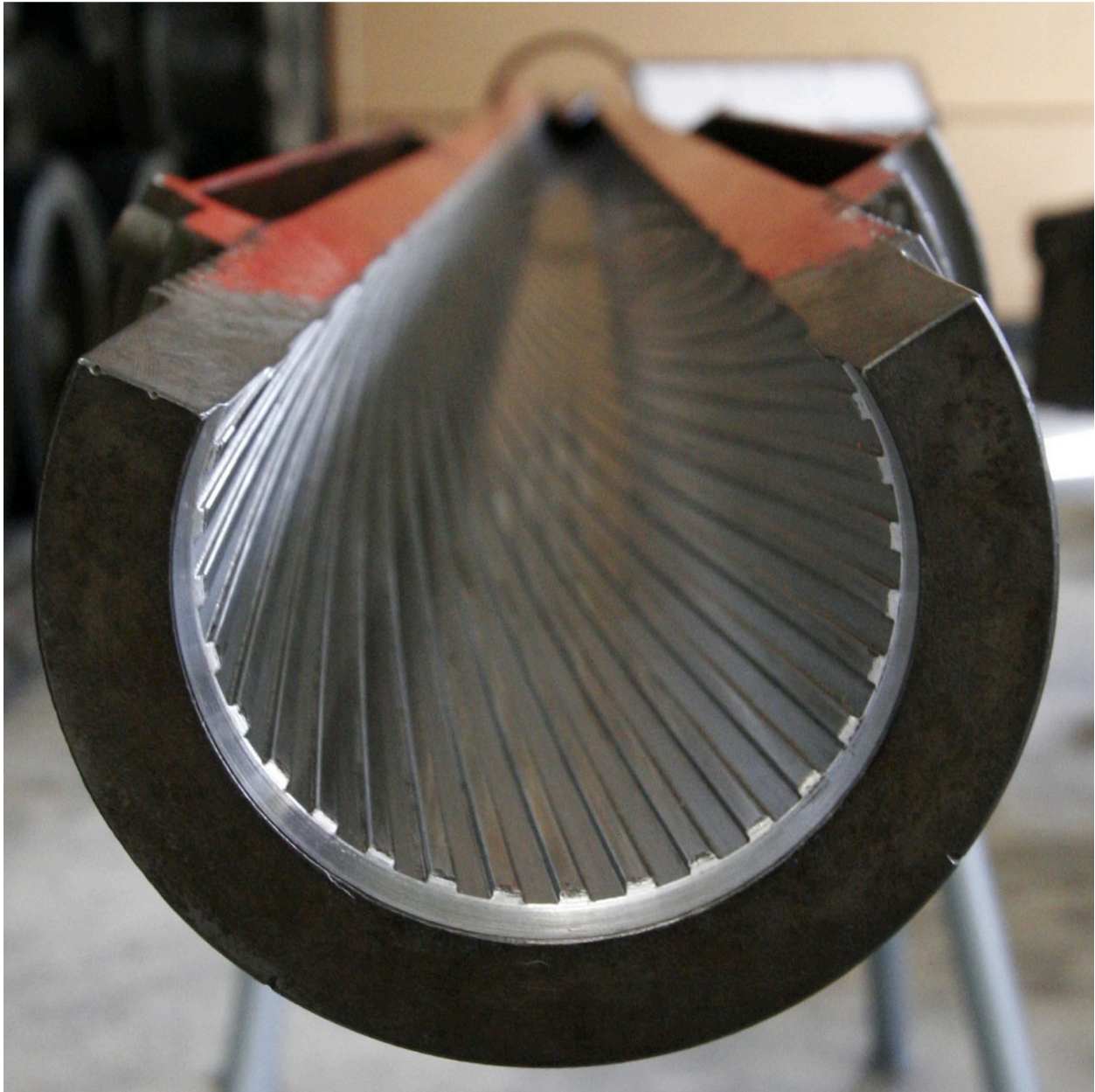
**Gaspard Kollner (14??–15??)****Augustus Kotter (14??–15??)****Rifled gun barrels (ca. 1498-1520)**

Figure 7.78: Gaspard Kollner and Augustus Kotter are credited with inventing rifled gun barrels around 1498–1520.

**Hans Stopler (15??–16??)**

**Revolvers (ca. 1580–1597)**



Figure 7.79: Hans Stopler was the first or one of the first gunsmiths to use a revolving section for multiple bullets, around 1580–1597.



**Johann Nikolaus  
von Dreyse  
(1787–1867)  
invented the  
bolt-action  
rifle (1824)**



**Dreyse Zündnadelgewehr bolt-action rifle  
(mass-produced from 1840 onward)**

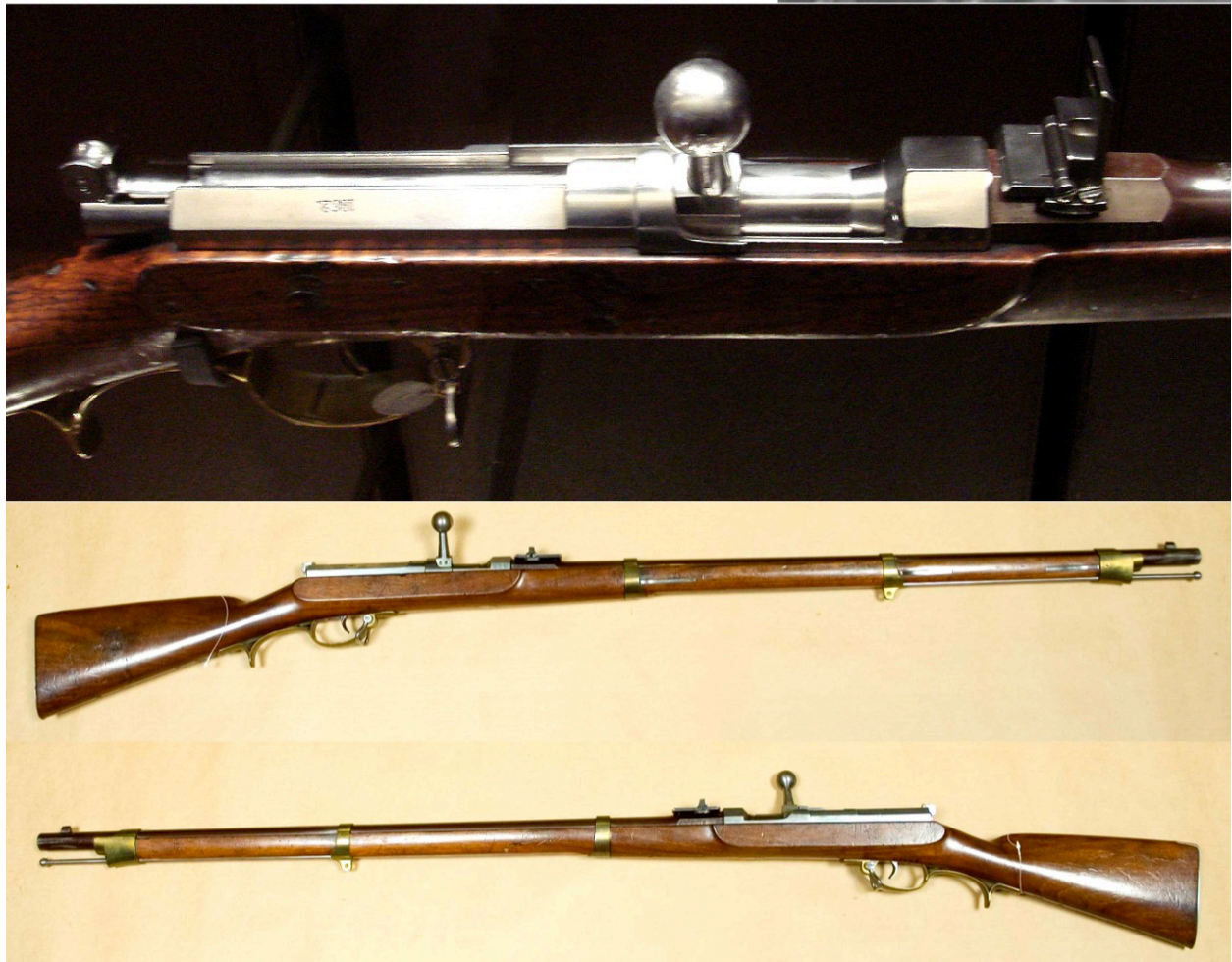


Figure 7.80: Johann Nikolaus von Dreyse invented the bolt-action rifle in 1824. His Dreyse Zündnadelgewehr bolt-action rifle was mass-produced from 1840 onward.





**Peter Paul  
Mauser  
(1838–1914)**



**Wilhelm  
Mauser  
(1834–1882)**



**Gewehr 71 bolt-action rifle (1871)**



**Gewehr 98 bolt-action rifle (1898)**



**Karabiner 98 kurz bolt-action rifle (1935)**



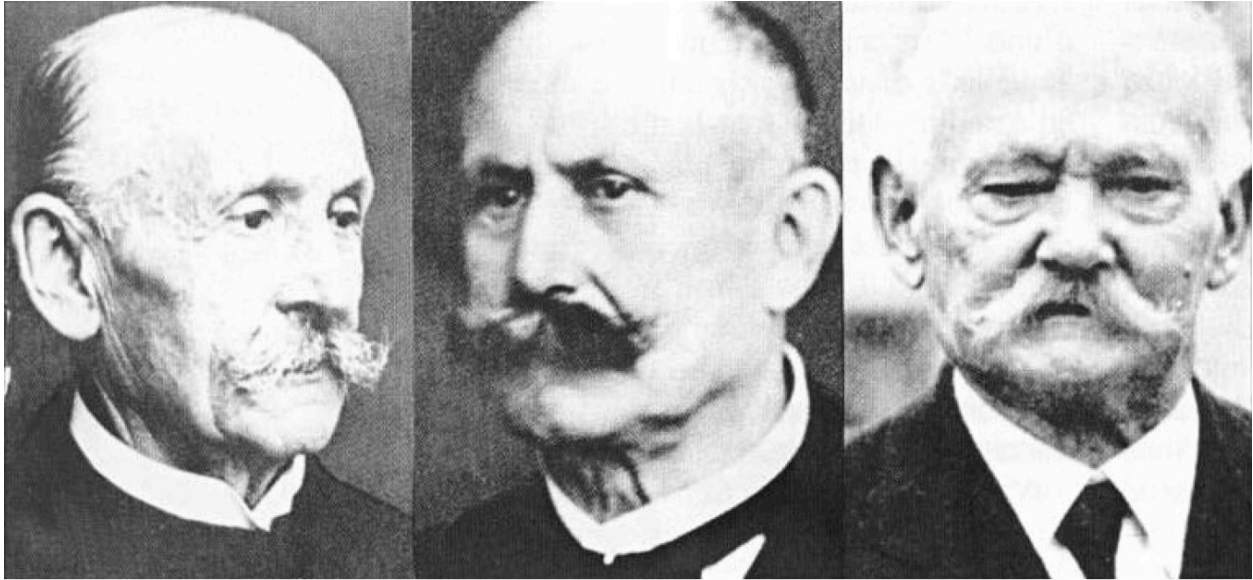
**Tankgewehr 18  
anti-tank rifle (1918)**

Figure 7.81: The brothers Peter Paul Mauser and Wilhelm Mauser invented the Gewehr 71 bolt-action rifle in 1871. The Mauser company later developed improved versions, including the Gewehr 98 (1898) and Karabiner 98 kurz (1935), as well as the scaled-up Tankgewehr 18 anti-tank rifle (1918).



Figure 7.82: Hugo Borchardt developed the first semi-automatic pistol, the Borchardt C93, in 1893. Georg Luger improved upon that design to create the Luger semi-automatic pistol in 1900.





**Fidel, Friedrich, & Josef Feederle (brothers)  
developed the Mauser C96 semi-automatic pistol (1896)**



Figure 7.83: The brothers Fidel, Friedrich, and Josef Feederle developed the Mauser C96 semi-automatic pistol in 1896.





**Walther PP  
(1929)**



**Fritz Walther  
(18??–19??)**

**Walther P 38  
(1938)**

Figure 7.84: Based on the earlier Luger design, Fritz Walther created the more advanced Walther PP in 1929 and Walther P 38 in 1938. Many modern handguns still use these same designs and features.

**Theodor Bergmann  
(1850–1931)**



**Louis Schmeisser  
(1848–1917)**

**Hugo Schmeisser  
(1884–1953)**



**Theodor Bergmann  
and Louis Schmeisser  
developed the  
Maschinengewehr MG 15,  
an early machine gun (1915)**



**Theodor Bergmann and Hugo Schmeisser  
developed the Maschinenpistole MP 18,  
the first practical submachine gun (1918)**

Figure 7.85: Theodor Bergmann and Louis Schmeisser developed the Maschinengewehr MG 15, an early machine gun, in 1915. Bergmann and one of Louis Schmeisser's sons, Hugo Schmeisser, developed the Maschinenpistole MP 18, the first practical submachine gun, in 1918.



**Louis Stange  
(1888–1971)  
developed the  
Maschinengewehr MG 30  
machine gun (1930)**



Figure 7.86: Louis Stange created the Maschinengewehr MG 30 machine gun in 1930.



**Heinrich Vollmer  
(1885–1961)  
developed the  
Maschinengewehr MG 34,  
the first general-purpose  
machine gun (1934)**

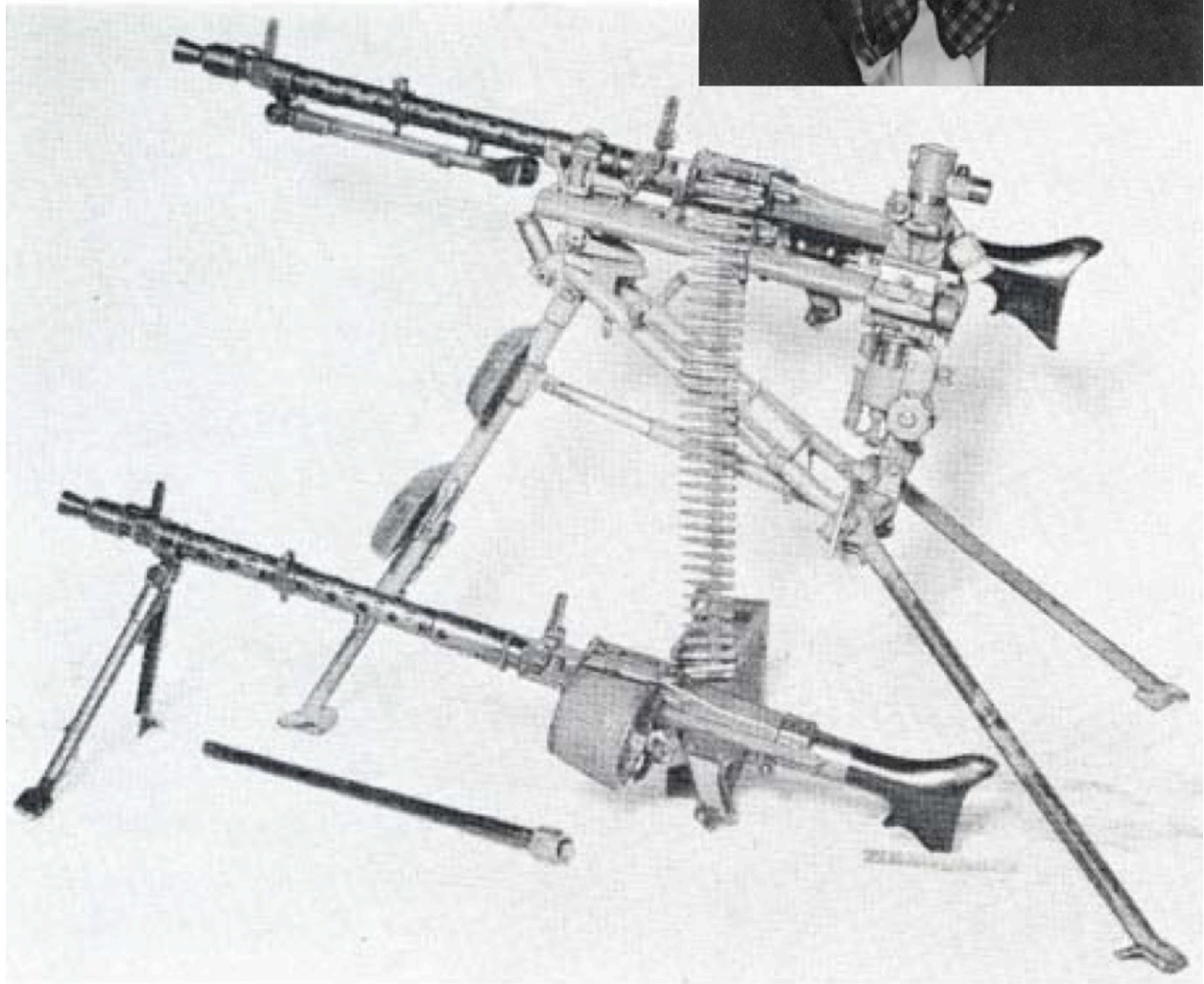
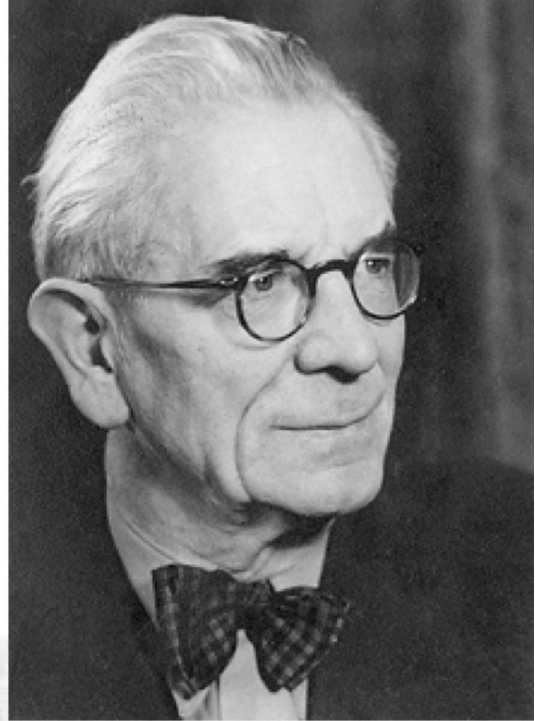


Figure 7.87: Heinrich Vollmer developed the first general-purpose machine gun, the MG 34, in 1934.

**Werner Gruner (1904–1995)  
developed the Maschinengewehr  
MG 42, an improved  
general-purpose machine gun (1942)**



Figure 7.88: Werner Gruner produced an improved general-purpose machine gun, the MG 42, in 1942.





**Hugo Schmeisser  
developed the  
Sturmgewehr StG 44  
selective-fire  
assault rifle (1944)**



Figure 7.89: Hugo Schmeisser created the Sturmgewehr StG 44 selective-fire assault rifle, the direct ancestor of modern assault rifles, in 1944.



**Wilhelm Stähle (1901–1974) and Ludwig Vorgrimler (1912–1983)**

**Developed the Sturmgewehr StG 45  
improved assault rifle (1945)**



Figure 7.90: Wilhelm Stähle and Ludwig Vorgrimler developed an improved selective-fire assault rifle, the Sturmgewehr StG 45, in 1945.



**Krummlauf (curved barrel)  
modified Sturmgewehr 44  
for shooting around  
corners (1944)**

**Also equipped with a  
periscope for seeing  
around corners  
(not shown)**

**Krummlauf with tank port,  
designed to defend exterior  
of tanks from close attackers**



Figure 7.91: The Krummlauf (curved barrel) modified Sturmgewehr 44 could shoot around corners, and was equipped with a periscope for seeing around corners (1944). Krummlauf rifles were also installed in tank ports to defend the exterior of tanks from close attackers.

### 7.6.2 Artillery

Engineers from the predominantly German-speaking world also made many important innovations in larger-caliber guns or artillery pieces.

In 1674, Menno van Coehoorn (Dutch, 1641–1704, Fig. 7.92) invented the Coehoorn or Coehorn style of mortar, which was widely used until the early twentieth century. He also made other innovations in methods of attacking or defending fortifications. *Encyclopedia Britannica* summarized some of his accomplishments [EB 2010]:

Dutch soldier and military engineer [...] who made a number of innovations in weaponry and siege-warfare techniques.

The son of an infantry officer, Coehoorn became a captain in 1667 and served in the Dutch War (1672–78) against Louis XIV of France. He attained prominence at the siege of Grave (1674), in which he introduced a highly effective bronze mortar, which subsequently was known as the Coehoorn mortar. His first book on siege techniques appeared in 1682 and was followed by his most important and most widely translated work, *Nieuwe vestingbouw* (1685; “New Fortress Construction”). He perfected a system of fortification suited to level terrain, such as that of the Netherlands, and he advocated a new strategy for citadel defense that involved the active deployment of troops instead of relying only on moats and ramparts.

After greatly assisting in the capture of Bonn (1689) at the outset of the War of the Grand Alliance, Coehoorn fought in the Battle of Fleurus (1690). He improved the fortifications of Namur but lost the city to a French siege in 1692 and did not regain it until 1695. In 1695 he was promoted to master general of the artillery, and in that post he oversaw fortification of several Dutch cities.

In 1880, engineers at Krupp invented the first modern mortars (Mörser), which were rifled breech-loaders designed for different calibers of ammunition: 7.5 cm, 15 cm, 21 cm, and other sizes (Fig. 7.93). They could be used either mounted on a wheeled carriage or unmounted on a flat base.

In 1909, engineers at Rheinmetall developed improved trench mortars (Minenwerfer), which were designed for three calibers of ammunition: 7.58 cm (leichte), 17 cm (mittlerer), and 25 cm (schwerer). Like the earlier Krupp mortars, all three sizes were used either mounted on a wheeled carriage or unmounted on a flat base. See Fig. 7.94. The innovative Krupp and Rheinmetall designs prompted other countries to copy and produce similar trench mortars.

Also in 1909, engineers at Skoda demonstrated the 30.5 cm M.11 Mörser siege howitzer, which could fire projectiles with a mass of 384 kg and a caliber of 30.5 cm up to a maximum range of 11.3 km. See Fig. 7.95. M.11 Mörser systems were used by Axis countries in World Wars I and II, and even by some Eastern Bloc countries during the Cold War.



Over the first several decades of the twentieth century, engineers at Krupp developed increasingly sophisticated giant artillery guns, such as:

- The Kurze Marine-Kanone 12 L/16 (also known as Big Bertha or Gamma-Gerät, 1909), which could fire projectiles with masses of 400–1160 kg and a caliber of 42 cm up to a maximum range of 14 km. See Fig. 7.96. Ten of these guns were used in World War I, and one in World War II.
- The Paris Gun (1918, so named because several were used to bombard Paris), which could fire projectiles with a mass of 106 kg and calibers of 22–24 cm up to a maximum range of 130 km. Its projectiles reached altitudes of 42 km, a record that was not broken until flights of the A-4 (V-2) rocket in 1942. See Fig. 7.98. Somewhat improved versions, the 21-cm K 12 (E) railway gun and the 28-cm K 5 (E) railway gun (sometimes called Anzio Annie by the Allies), were produced and used during World War II. (In the 1950s, the United States produced a copy of the 28-cm German gun, officially named the M65 and unofficially called Atomic Annie, since it could fire a specially designed W9 nuclear artillery shell. Was the W9 fission bomb also a copy of a German design?)
- The Schwerer Gustav gun (1941), which could fire projectiles with a mass of 7.1 tons and a caliber of 80 cm up to a maximum range of 47 km. It was the heaviest mobile artillery piece ever built, fired the heaviest artillery shells ever created, and had the largest caliber ever used in combat. See Fig. 7.99. During the war, the Schwerer Gustav gun was used to destroy targets on the Eastern Front, but the gun itself was (mostly) destroyed by Germany at the end of the war to prevent it from being captured intact by Allied troops.
- The Hochdruckpumpe or “V-3” gun (1944), which could fire projectiles with a mass of 140 kg and a caliber of 15 cm up to a maximum range of 165 km [Margry 2001]. See Fig. 7.100. The Hochdruckpumpe was just one of several unrelated projects competing for the title of “V-3,” the next large new weapon system to be publicly announced after the V-2 rocket. (A piloted V-1 cruise missile and multiple large rockets were also called “V-3” at times—see Appendix E.) The Hochdruckpumpe had a clever design in which propellant charges were planted in side chambers at regular intervals along the main barrel, and ignited sequentially as the projectile passed them. One such gun was successfully test fired on the Baltic coast of Pomerania in May 1944, and two guns were used to bombard Luxembourg during the period December 1944–February 1945. The guns were captured and studied by the U.S. Army at the end of the war.

Karl Puff (German, 18??–19??) patented a squeeze bore or tapered bore gun design in 1904. Just as reducing the opening of a garden hose with one’s thumb increases the flow velocity of water, steadily reducing the cross-sectional area of a gun barrel toward the end increases the muzzle velocity of a bullet. Hermann Gerlich (German, 18??–19??) filed more detailed patent applications on squeeze bore designs in 1929 and built such guns; see Fig. 7.101. The German military used squeeze bore guns such as the Pak 41 anti-tank gun (1941).

In September 1945, R. P. Linstead and T. J. Betts, the British and American chairs of the Combined Intelligence Objectives Subcommittee (CIOS), listed a number of important German innovations for large guns [AFHRA A5186 electronic version pp. 904–1026, Ch. 4, p. 41]:

Guns ranging from 30 mm to 350 mm calibers were designed to operate without recoil. Certain of these weapons adopted the principle of a “blow-out” disc located at the rear of the powder chamber. This disc was designed to obdurate the powder pressure for a short interval while a given pressure build-up occurs in the chamber, it then releases this pressure to the rear of the weapon. In this manner equal components of momenta are achieved and recoil eliminated.

The advantages of such a development are many. Construction is greatly simplified and elaborate recoil and counter recoil mechanisms are eliminated with savings in weight and material. Thus comparatively large caliber weapons can be adapted for aircraft mounting due to the elimination of recoil and accompanying trunnion stress.

The Germans had made considerable progress with our rigidly mounted tank guns of comparatively large calibers. By the elimination of recoil mechanisms, a considerable saving of space for tank crews was achieved and tank turrets could be fitted with larger guns.

The German design of smooth-bore, high velocity weapons, firing fin-stabilized projectiles was another development worth recording. These weapons resulted in extremely long ranges, excellent accuracy, and lessened gun wear.

### 7.6.3 Shaped-Charge Anti-Tank Weapons

German-speaking creators also invented shaped-charge anti-tank weapons. See pp. 558–563.

**Menno van Coehoorn  
(1641–1704)**



**Coehoorn/Coehorn  
mortar (1674)**



Figure 7.92: In 1674, Menno van Coehoorn invented the Coehoorn or Coehorn style of mortar, which was widely used until the early twentieth century. He also made other innovations in methods of attacking or defending fortifications.



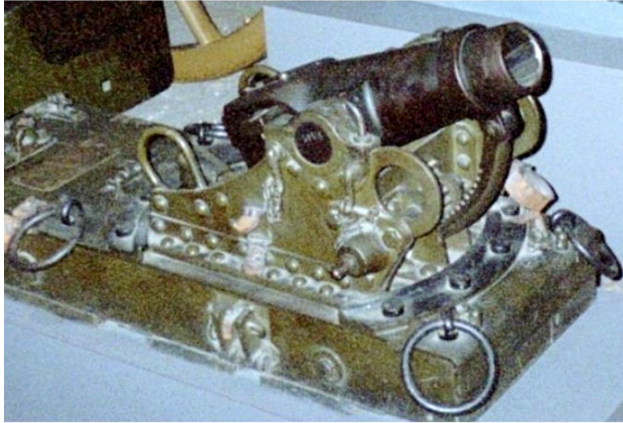
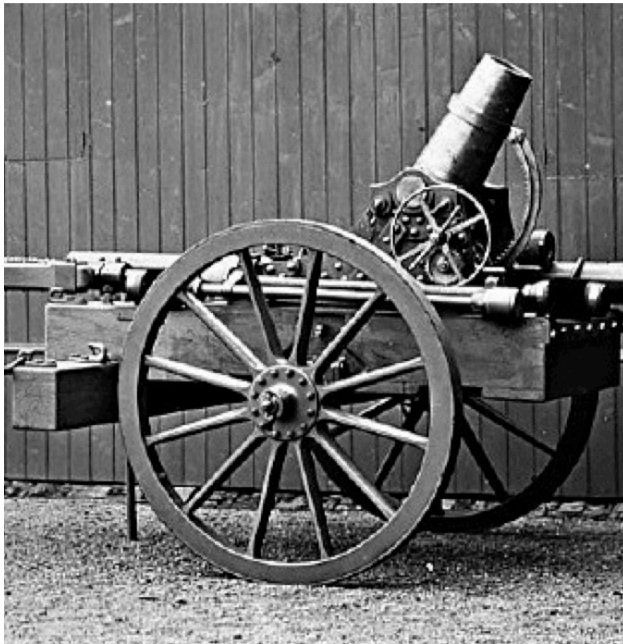
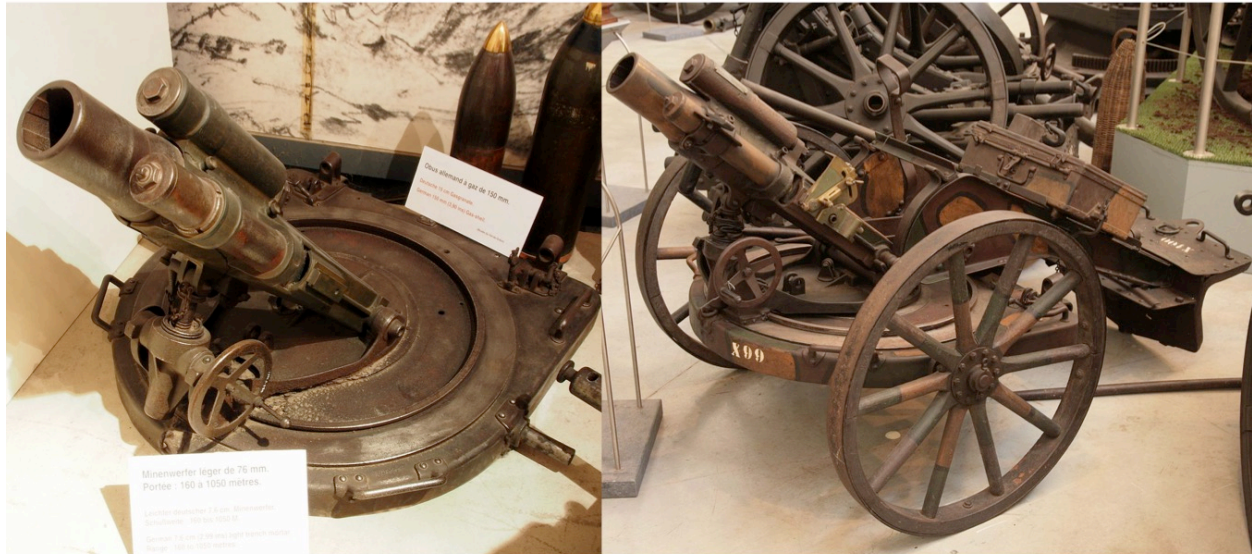
**Krupp Mörser rifled mortars (1880)****Krupp 7.5 cm Mörser****Krupp 15 cm Mörser****Krupp 15 cm Mörser  
on a wheeled carriage****Krupp 21 cm Mörser**

Figure 7.93: In 1880, engineers at Krupp invented the first modern mortars (Mörser), which were rifled breech-loaders designed for different calibers of ammunition: 7.5 cm, 15 cm, 21 cm, and other sizes. They could be used either mounted on a wheeled carriage or unmounted on a flat base.

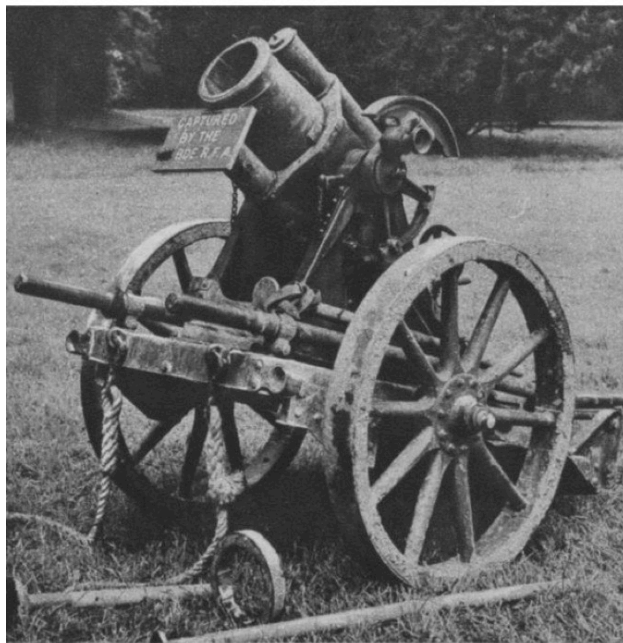


## Trench mortars (Rheinmetall, 1909)

### 7.58 cm leichte Minenwerfer



### 17 cm mittlerer Minenwerfer



### 25 cm schwerer Minenwerfer



Figure 7.94: In 1909, engineers at Rheinmetall developed improved trench mortars (Mineswerfer), which were designed for three calibers of ammunition: 7.58 cm (leichte), 17 cm (mittlerer), and 25 cm (schwerer). Like the earlier Krupp mortars, all three sizes were used either mounted on a wheeled carriage or unmounted on a flat base.





**30.5 cm M.11 Mörser  
(Skoda, 1909)**

**Projectiles: 384 kg**

**Caliber: 30.5 cm**

**Range: 11.3 km**

Figure 7.95: In 1909, engineers at Skoda demonstrated the 30.5 cm M.11 Mörser, which could fire projectiles with a mass of 384 kg and a caliber of 30.5 cm up to a maximum range of 11.3 km.





**Kurze Marine-  
Kanone 12 L/16,  
a.k.a. Big Bertha  
or Gamma-Gerät  
(Krupp, 1909)**

**Projectiles: 400–1160 kg**

**Caliber: 42 cm**

**Range: 14 km**



Figure 7.96: In 1909, engineers at Krupp demonstrated the Kurze Marine-Kanone 12 L/16 (also known as Big Bertha or Gamma-Gerät), which could fire projectiles with masses of 400–1160 kg and a caliber of 42 cm up to a maximum range of 14 km.



**NARA Still Pictures, RG 111 SCA—Records of the Chief Signal Officer. Prints: U.S. Army Signal Corps Photographs of Military Activity During WW II and the Korean Conflict, 1941-1954. Captured German Equipment, German, Box 3344, Book 5, SC 205713, 205714.**

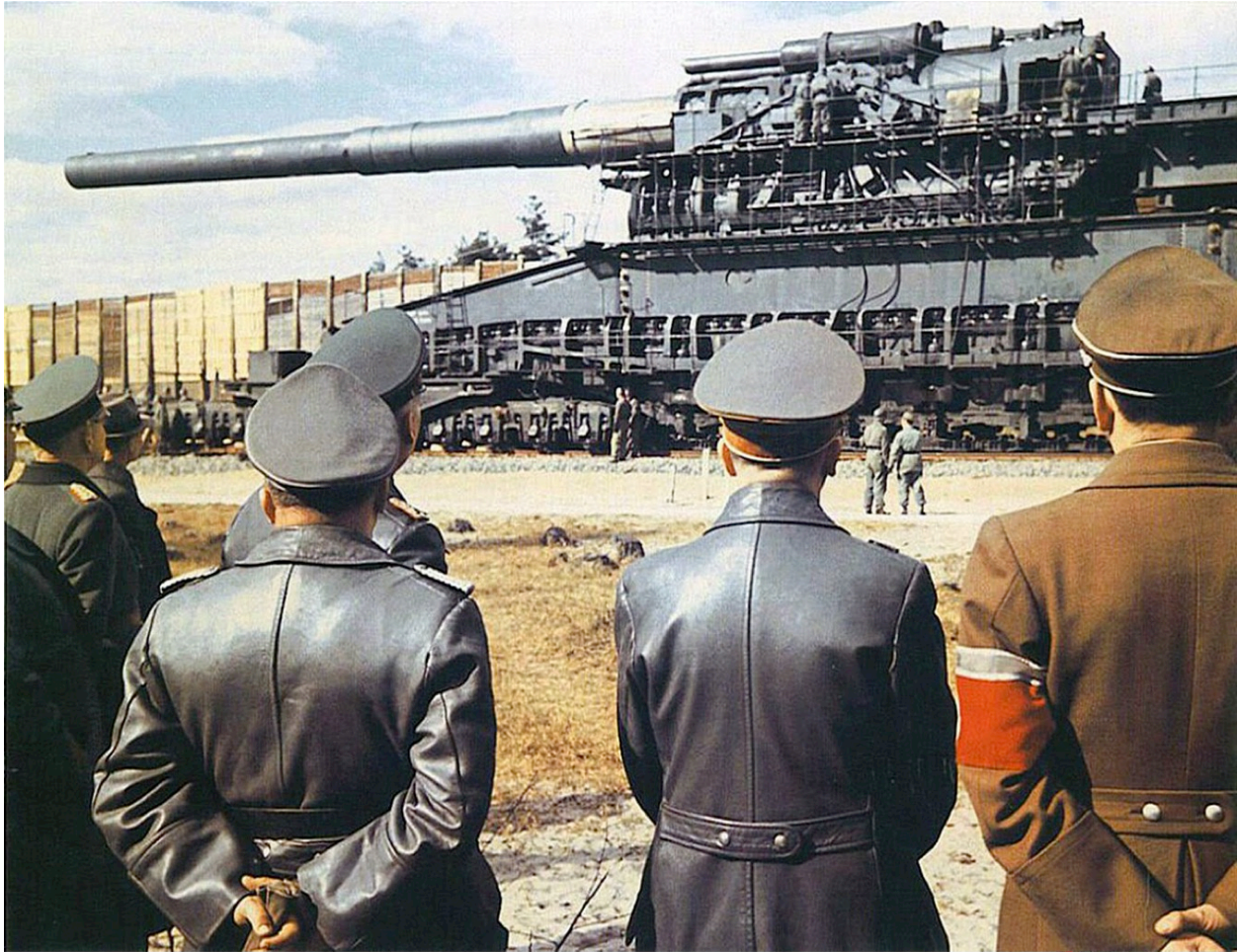


Figure 7.97: Original photo caption: “U.S. Army Ordnance men inspect howitzer-like gun captured by 30th Division units. The gun fires a rocket-type shell 15 inches in diameter, weighing about 1,500 pounds. 4/2/45” [NARA Still Pictures, RG 111 SCA—Records of the Chief Signal Officer. Prints: U.S. Army Signal Corps Photographs of Military Activity During WW II and the Korean Conflict, 1941-1954. Captured German Equipment, German, Box 3344, Book 5, SC 205713, SC 205714.]









**Schwerer Gustav gun  
(Krupp, 1941)**

**Projectiles: 7.1 tons**

**Caliber: 80 cm**

**Range: 47 km**



Figure 7.99: In 1941, engineers at Krupp demonstrated the Schwerer Gustav gun, which could fire projectiles with a mass of 7.1 tons and a caliber of 80 cm up to a maximum range of 47 km.



**Hochdruckpumpe  
V-3 gun  
(Krupp, 1944)**

**Projectiles: 140 kg**

**Caliber: 15 cm**

**Range: 165 km**



Figure 7.100: In 1944, engineers at Krupp demonstrated the Hochdruckpumpe or “V-3” gun, which could fire projectiles with a mass of 140 kg and a caliber of 15 cm up to a maximum range of 165 km.



**Karl Puff (18??–19??)**

**Hermann Gerlich (18??–19??)**

**Squeeze bore or tapered bore guns for increased muzzle velocities**

Jan. 30, 1934.

H. GERLICH  
PROJECTILE

1,944,885 Jan. 30, 1934.

H. GERLICH

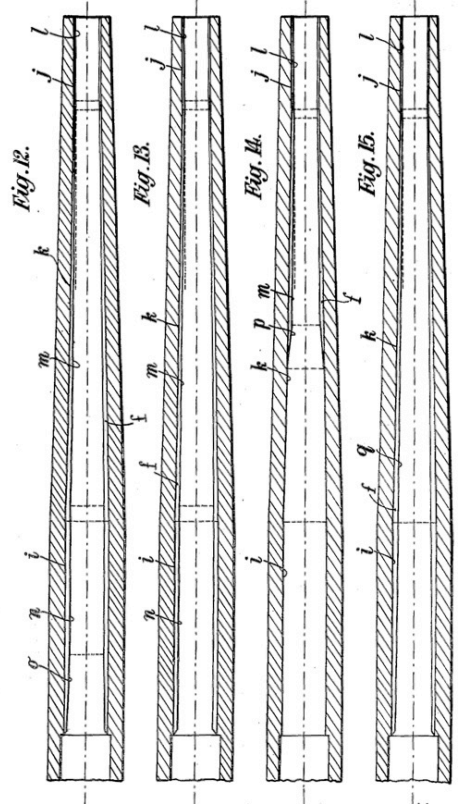
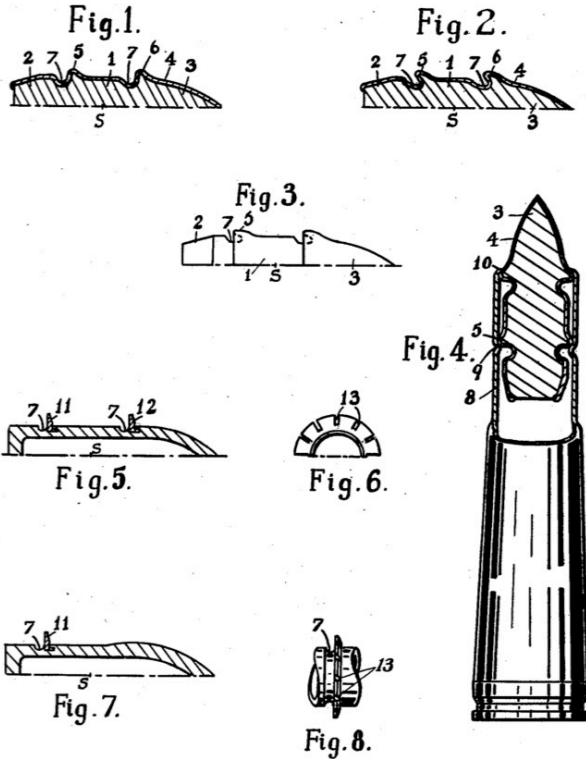
1,944,883

Original Filed Dec. 4, 1930

PROJECTILE PROPELLING APPARATUS

Filed Dec. 4, 1930

2 Sheets-Sheet 2



INVENTOR  
Hermann Gerlich



Figure 7.101: Karl Puff patented a squeeze bore or tapered bore gun design for increasing muzzle velocities in 1904. Hermann Gerlich filed more detailed patent applications in 1929 and built such guns. The German military used squeeze bore guns such as the Pak 41 anti-tank gun (1941).



### 7.6.4 Electromagnetic Railguns

Whereas conventional guns and artillery use the chemical energy of an explosion to propel a projectile and use a barrel to guide the projectile, electromagnetic railguns use the energy of electric and/or magnetic fields to propel a projectile and use rails to guide it. Multiple groups of German-speaking scientists developed and demonstrated electromagnetic railguns during World War II; see Fig. 7.102. The best-documented group was led by Joachim Hänsler (German, 19??–19??), but there were other groups as well.

Hänsler built and demonstrated electromagnetic railguns capable of launching projectiles at velocities up to 1200 meters/second, or over 3.5 times the speed of sound. By 1945, he was continuing to develop larger and faster railguns, planning to reach velocities over 2000 meters/second.<sup>7</sup>

Manfred von Ardenne (German, 1907–1997, p. 1293) led an even larger program to develop and produce electromagnetic railguns. Currently there are only a few known reports in archives that mention his program.<sup>8</sup> These reports demonstrate that during the war, electromagnetic railguns had moved beyond the stage of simple experiments. Very large railguns were being mass-produced in at least 13 factories, and specific launch sites for them were being built and equipped with up to 10 megawatts of dedicated electrical power per railgun.

Even nowadays, electromagnetic railguns are considered to be a high-tech “weapon of the future.” The best modern railguns are essentially just larger versions of Joachim Hänsler’s and Manfred von Ardenne’s 1944–1945 devices, and can now fire projectiles at approximately twice the velocity of Hänsler’s wartime railguns. Since Hänsler’s (and perhaps von Ardenne’s) detailed technical reports and even some of his equipment were brought back to the United States by the Alsos Mission, CIOS, and other teams of investigators in 1945, presumably such modern railguns are directly derived from the wartime German work.

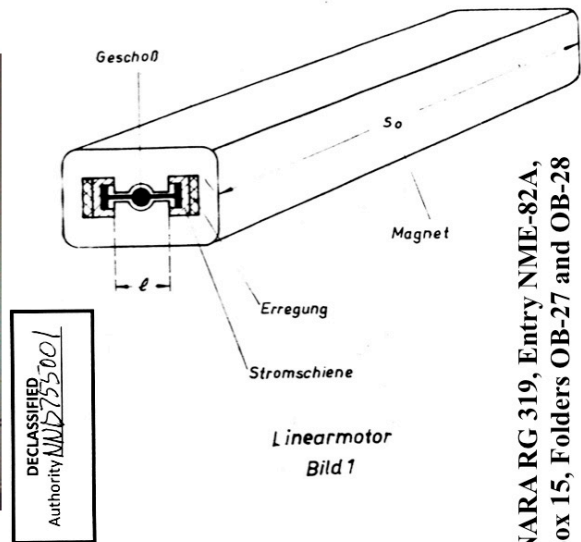
For more information, see Section C.5. Much more archival research should be conducted to elucidate the history of electromagnetic railguns in the German-speaking world, as well as the impact of those innovators and innovations on postwar electromagnetic railguns in other countries.

---

<sup>7</sup>CIOS XXXI-59; CIOS XXXI-84; NARA RG 319, Entry NM-82A, Box 15, Folders OB-27 and OB-28.

<sup>8</sup>AFHRA 25193 No. 2641 Posen; AFHRA 25216 electronic version p. 423; reports shown in Witkowski 2010, pp. 129–131, and Witkowski 2013, pp. 93–94.

## Electromagnetic railguns

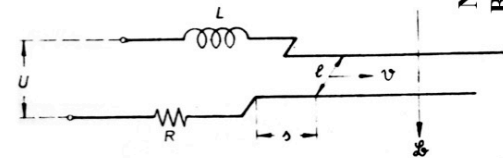


DECLASSIFIED  
Authority NND 755001

NARARG 319, Entry NME-82A,  
Box 15, Folders OB-27 and OB-28

By 1945:

- 1200 m/sec velocity (Mach 3.6)
- Working toward >2000 m/sec
- Mass produced in 13 factories
- Launch sites built
- 10 megawatts provided for launchers



Stromkreis des Linearmotors  
Bild 2

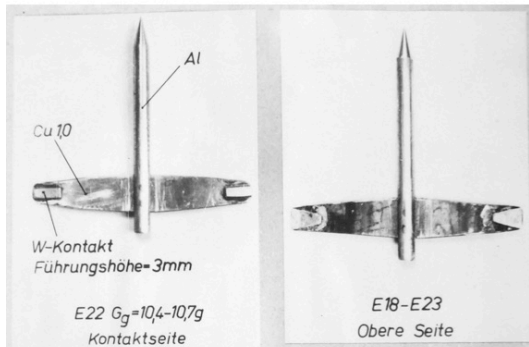


Bild 3

Bild 4

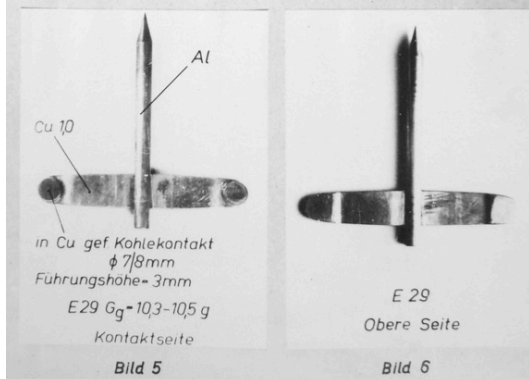


Bild 5

Bild 6

Joachim  
Hänsler  
(19??–  
19??)

Manfred  
von  
Ardenne  
(1907–  
1997)

Many  
other  
engineers

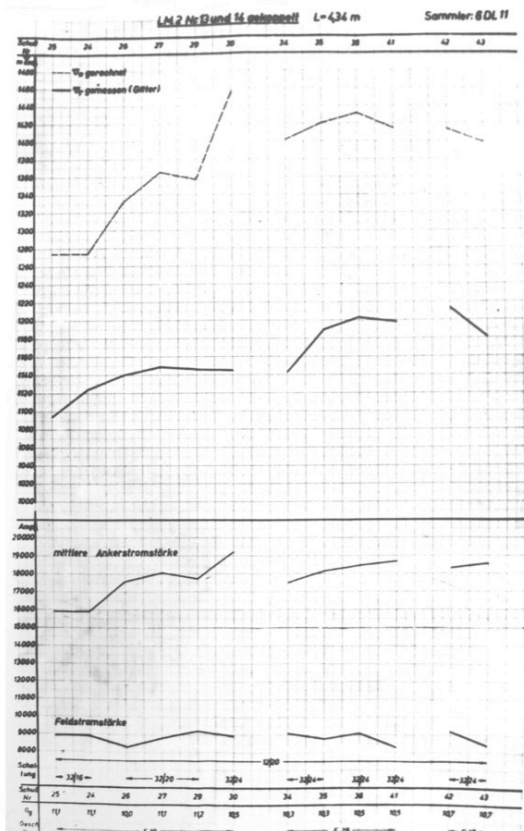


Figure 7.102: During World War II, Joachim Hänsler, Manfred von Ardenne, and other German-speaking scientists developed and demonstrated electromagnetic railguns capable of launching projectiles at velocities of at least 3.6 times the speed of sound. By the end of the war, railguns were being mass-produced for deployment on the battlefield.

### 7.6.5 Flamethrowers

As shown in Fig. 7.103, Richard Fiedler (German, 18??–19??) invented the modern flamethrower in 1901, and continued to develop improved versions until 1918.

Bernhard Reddemann (German, 1870–1938) and Gábor Szakáts (Austro-Hungarian, 1892–1937) began developing improved flamethrowers in 1904 and 1915, respectively.

Early flamethrowers included:

- The three-person Grossflammenwerfer (Grof, 1912, Fig. 7.103) with a large fuel tank that was not portable.
- The two-person portable Kleinflammenwerfer (Kleif, 1912, Fig. 7.104).
- The one-person portable Wechselapparat (Wex, 1916, Fig. 7.104).

One-person portable flamethrowers were further improved during the Third Reich, resulting in the Flammenwerfer 35 (1935, Fig. 7.105) and the lighter-weight Flammenwerfer 41 (1941, Fig. 7.106).

German-speaking scientists continued to make improvements in flamethrowers throughout World War II, and those improvements were transferred to other countries after the war. For example, BIOS 250, *German Research into Increasing Range and Performance of Flame Throwers*, p. 5, noted several wartime innovations that were identified for transfer to Allied countries in 1945:

I should like to bring to the attention the following four points arising out of this visit to investigate German flame throwers. The interrogation and search for weapons was guided principally by the endeavor to find out what the Germans were about to develop and what theoretical ideas they had on the projection of fluids, and not so much on existing battle weapons.

1. B. Smits in Kassel has developed an original idea in the “creep spark plug”, the application of which to the ignition of flame throwers is fool-proof and 100 per cent efficient and was just being applied to their tank flame throwing units.

2. The Marine Research Station at Kiel (Danisch Nienhof) had developed a dual nozzle flame thrower, which had the advantage of improving the psychological effect of the thickened flame throwing fuel jet besides definitely improving its lethal and anti-personnel efficiency. This overcomes one of the chief criticisms of the thickened fuel flame jet in that in the effort to improve range you lost the anti-morale effect of the old type of flame thrower. The dual combination of Ingolin and heavy density oils is worth noting.

3. The results of Dr. Buch in Göppingen using the “sago” or dispersed swollen lumps in thickened fuel principle are very interesting in improving the range of the flame thrower into the 200 yards with a 32 mm. nozzle and 40–50 atmospheres pressure.



4. I would recommend the removal of Commander Jentsch and Dr. Eckhardt from the Marine Research Station at Danisch Nienhof to Langhurst or elsewhere in England, on the grounds that they are exceptional practical scientists, who could give us great assistance in the development of oil technology in this country.

I think if handled correctly they would be very willing and successful collaborators in technical developments much required here. Anyhow their stay in Danisch Nienhof is a complete waste of good human material.

Owing to the time factor, the visit could not be completed and the flame throwing research units in Munich and Vienna and an investigation of the Mauser works at Oberndorf should be undertaken. In particular, the Research Laboratory of Professor Ostwald in Munich was the first establishment (1926) to investigate the increase of viscosity of hydrocarbons by the dispersion of soaps in the oils.

**Richard Fiedler**  
(18??–19??)  
invented first modern  
flamethrowers (1901)

**Bernhard Reddemann**  
(1870–1938)  
improved  
flamethrowers (1904–)

**Gábor Szakáts**  
(1892–1937)  
improved  
flamethrowers (1915–)



**Grossflammenwerfer Grof with fixed (not portable) fuel tank (1912)**



Figure 7.103: Richard Fiedler invented the modern flamethrower in 1901 and developed improved versions until 1918. Bernhard Reddemann and Gábor Szakáts began developing improved flamethrowers in 1904 and 1915, respectively. The Grossflammenwerfer (Grof, 1912) had a fixed (nonportable) fuel tank, required a crew of three operators, and had a range of 35 meters.



**Two-person portable  
Kleinflammenwerfer  
Kleif (1912)**



**One-person portable  
Wechselapparat  
Wex (1916)**

Figure 7.104: The two-person portable Kleinflammenwerfer (Kleif, 1912) weighed 32 kilograms and had a range of 20 meters. The one-person portable Wechselapparat (Wex, 1916) weighed ?? kilograms and had a range of 15 meters.



**One-person  
portable  
Flammenwerfer 35  
(1935)**



Figure 7.105: The one-person portable Flammenwerfer 35 (1935) weighed 36 kilograms and had a range of 25 meters.

**One-person portable  
Flammenwerfer 41 (1941)**



Figure 7.106: The one-person portable Flammenwerfer 41 (1941) weighed 29 kilograms and had a range of 32 meters.

## 7.7 Ocean Engineering

Creators from the predominantly German-speaking scientific world masterminded the development of submarines and related technologies, producing not only undersea- or U-boats that revolutionized warfare during World Wars I and II, but also submarine technologies that were the foundation of postwar submarine designs by the United States, Soviet Union, and other countries.<sup>9</sup>

This section covers the contributions of German-speaking scientists and engineers to:

7.7.1. Early experimental submarines

7.7.2. Military submarines

7.7.3. Bathyscaphes

7.7.4. Rotor ships

### 7.7.1 Early Experimental Submarines

As shown in Fig. 7.107, Cornelius Drebbel (Dutch, 1572–1633) built a series of oar-propelled wooden submarines in the 1620s, culminating in a demonstration of the largest one in 1624 in the Thames for the British royal court. *Encyclopedia Britannica* explained [EB 2010]:

Dutch inventor who built the first navigable submarine.

An engraver and glassworker in Holland, Drebbel turned to applied science and in 1604 went to England, where King James I became his patron. He devised an ingenious “perpetual motion clock,” actuated by changes in atmospheric pressure and temperature, which greatly enhanced his reputation. In 1620 he completed his “diving boat.” Propelled by oars and sealed against the water by a covering of greased leather, the wooden vessel travelled the River Thames at a depth of 12 to 15 feet (about 4 metres) from Westminster to Greenwich. Air was supplied by two tubes with floats to maintain one end above water.

Drebbel also discovered the use of tin compounds as mordants for cochineal, a scarlet dye, and suggested a method of making sulfuric acid by the oxidation of sulfur. Among many other inventions attributed to him are the compound microscope, an improved thermometer, and self-regulating ovens.

---

<sup>9</sup>Bishop and Ross 2016; Breyer 1999; Broelmann 2012; Geoghegan 2013; Herzog 1996; Hutchinson 2001; Köberl 1990; Köhl 1988; Krzyształowicz 2012; Möller 2000; Polmar and Moore 2004; Eberhard Rössler 1987, 1998, 2005, 2010, 2016; Sakaida 2006; Schulze-Wegener 1997; Wetzel 1999; Wise 2005; NYT 1945-11-22 p. 16a, 1947-02-12 p. 10.



Wilhelm Bauer (Bavarian, 1822–1875) built and demonstrated the *Brandtaucher* prototype submarine in 1850, and the larger *Seeteufel* in 1855. He also raised a sunken ship using balloons. See Fig. 7.108. *Jane's Submarines* described his history of submarine development [Hutchinson 2001, pp. 10-11]:

In 1850, the former artillery non-commissioned officer, Wilhelm Bauer (1822–1875) built the *Brandtaucher* ('Fire Diver') in Kiel, Germany: an unattractive 27-foot long craft with a short, stubby steel hull, a low conning tower right forward at the bows with two bulls-eye portholes, and a displacement of nearly 39 tons. It accommodated three men. Again, it relied on muscle power to drive the screws, via a large treadmill mounted amidships—after earlier tests with clockwork again failed to supply enough power. The aim was to develop a weapon that would disrupt a Danish naval blockade of northern German ports. It was tested to depths of just over 50 feet but was never deployed operationally after the first test, on February 1 1851, nearly became a disaster.

The boat plunged to the sea bottom, 54 feet below the surface and after more than five terrifying hours, Bauer opened the flood valves to equalise the pressure within the hull to allow escape. When the seawater reached the chins of Bauer and his two fellow crewmen, a bubble of air blew the hatch open and all three shot to the surface—to survive. It was the first successful submarine escape.

*Brandtaucher* was later raised from the bottom of Kiel Harbour in 1887 and renovated. This remains the oldest preserved submarine in the world and can be seen today in the Deutsches Armeemuseum, Neuer Garten, Potsdam, Germany.

Four years later, Bauer built the *Seeteufel* ('Sea Devil') for the Russian Navy, a much larger and more ambitious design, with a steel hull, a 13 man crew, and a small engine for use on the surface. The flat, sausage-shaped hull, launched from the Leuchtemburg yard in St Petersburg, on November 2 1855, was 52-foot long and 12-foot wide. The problem of sub-surface propulsion remained intractable with the *Seeteufel* relying on his earlier, cumbersome system of a treadmill-cranked screw. Water ballast was controlled by a system of hand-pumps. The boat made 133 successful dives[...]

Julius Kröhl (Prussian, 1820–1867), shown in Fig. 7.108, built the Sub Marine Explorer prototype submarine during the period 1863–1867. Naval historian Jobst Broelmann provided some insight into Kröhl's otherwise rather mysterious submarine development program [Broelmann 2012, pp. 62–63]:

Dies Argument soll den deutschen Ingenieur Julius H. Kröhl bewogen haben, ein Unterwasserförderschiff zu bauen, das die Prinzipien von Payerne aufgriff. Ein Angebot von William Henry Tiffany, dem Bruder des Gründers der Firma Tiffany, ermöglichte Kröhl den Bau. Tiffany war Hauptgesellschafter der Pacific Pearl Company, die Perlen im Pazifik ernten wollte und dazu einen geeigneten Tauchapparat brauchte. Das Boot wurde in einem Dock in Brooklyn gebaut und 1866 vorgestellt.

Die längliche Form des Bootes entstand aus einer Reihe hintereinander angeordneter Räume, die wie Taucherglocken unten zu öffnen waren. Am Heck war ein manueller Propellerantrieb vorgesehen. Da bei diesen Apparaten Taucher das Boot durch Luken verlassen sollten, musste ihr Innendruck der Wassertiefe entsprechen oder eine Druckschleuse eingebaut sein. Im ersten Falle glichen sie also einer frei beweglichen Taucherglocke, die ohne Verbindung zur Oberfläche agieren konnte. Getaucht wurde durch einströmendes Wasser, aufgetaucht durch Einblasen von Druckluft.

Das Explorationsschiff Kröhls wurde 1867 für kurze Zeit in Panama eingesetzt. Es wird vermutet, dass die Betreiber der Taucherkrankheit erlagen. Erst 2002 konnte ein Wrack in dieser Region als die ehemalige Konstruktion Kröhls identifiziert werden.

This argument is said to have persuaded the German engineer Julius H. Kröhl to build an underwater production ship that took up Payerne's principles. An offer from William Henry Tiffany, the brother of the founder of the Tiffany company, enabled Kröhl to build it. Tiffany was the main shareholder of the Pacific Pearl Company, which wanted to harvest pearls in the Pacific and needed a suitable diving apparatus to do so. The boat was built in a dock in Brooklyn and presented in 1866.

The elongated shape of the boat was created from a row of rooms arranged one behind the other, which opened like diving bells at the bottom. A manual propeller drive was provided at the stern. Since divers were supposed to leave the boat through hatches, their internal pressure had to correspond to the water depth or a pressure lock had to be installed. In the first case they resembled a freely movable diving bell, which could operate without connection to the surface. Diving was done by inflowing water, surfaced by blowing in compressed air.

The exploration ship Kröhl's was used in Panama for a short time in 1867. It is assumed that the operators succumbed to the diving sickness. Only in 2002 a wreck in this region could be identified as the former construction of Kröhl.

**Cornelis Drebbel  
(1572–1633)**

**Replica of Drebbel's  
oar-propelled wooden submarine**



**Demonstration of Drebbel's submarine in the Thames (1624)**

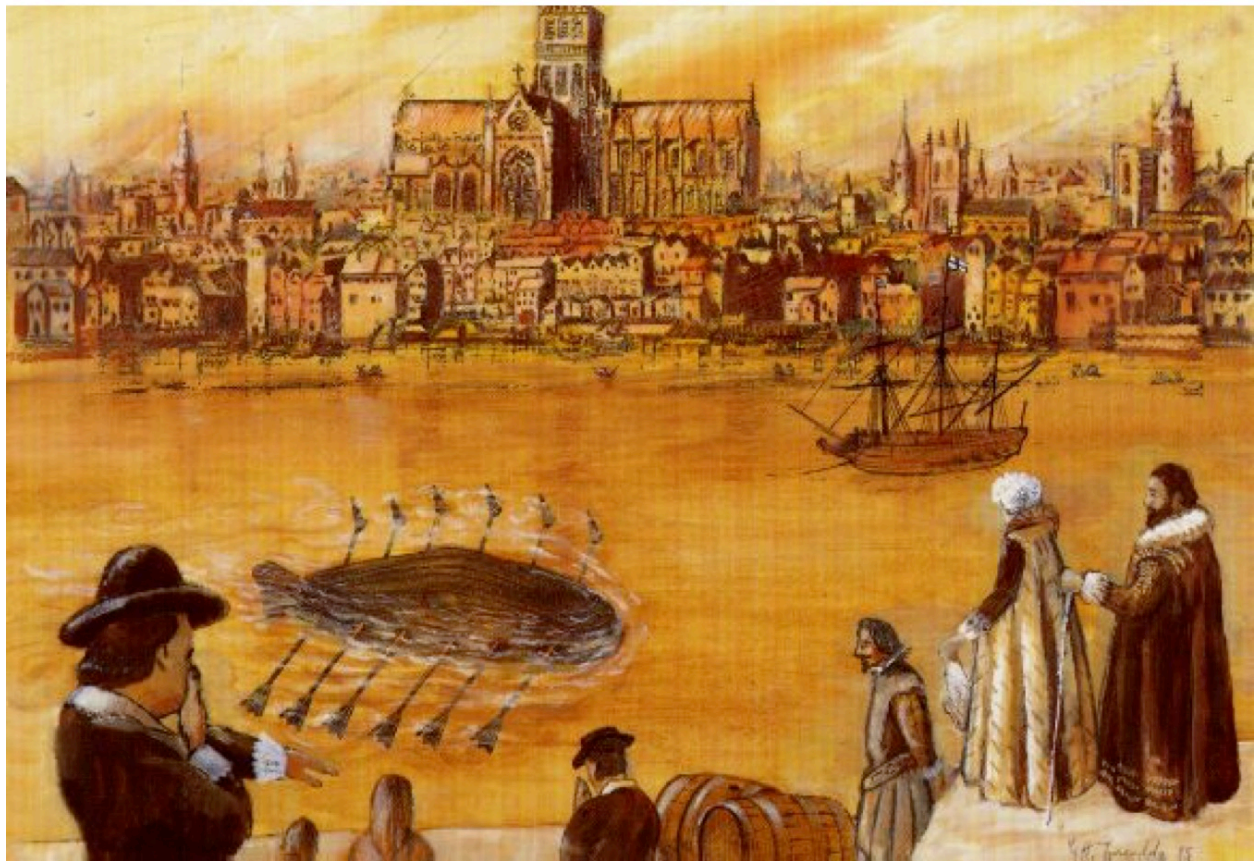


Figure 7.107: Cornelis Drebbel built a series of oar-propelled wooden submarines, culminating in a demonstration of the largest one in 1624 in the Thames.



**Wilhelm Bauer  
(1822–1875)**



**Brandtaucher prototype  
submarine (1850)  
Bundeswehr Museum, Dresden**



**Julius Kröhl  
(1820–1867)**

**Sub Marine Explorer prototype  
submarine (1863–1867)  
hull on Pearl Islands**



Figure 7.108: Wilhelm Bauer built and demonstrated the Brandtaucher prototype submarine in 1850. Julius Kröhl developed the Sub Marine Explorer prototype submarine 1863–1867.

### 7.7.2 Military Submarines

Despite the early innovations by Cornelius Drebbel, Wilhelm Bauer, and Julius Kröhl, work on submarine prototypes shifted to France in the late nineteenth century, perhaps due to the fictional inspiration provided by Jules Verne's *Twenty Thousand Leagues Under the Sea* (1870). By the early twentieth century, though, German submarine designers had taken the lead, and continued to lead through World War II.

As illustrated in Fig. 7.109, some key submarine designers included:

- Christoph Aschmoneit (German, 1901–1984): World War II submarines
- Gustav Berling (German, 1869–1943): World War I submarines
- Fritz Bröking (German, 1877–1961): Type VII and Type XXI submarine propulsion
- Ulrich Gabler (German, 1913–1994): Type XXII, XVII A, and XXVI submarines
- Friedrich Schürer (German, 1881–1948): Type VII and Type XXI submarine propulsion
- Hellmuth Walter (German, 1900–1980): air-independent submarine propulsion; V 80 teardrop shape

Figure 7.110 presents plans for the Type UB III U-boat (built 1915–1918), as well as a photo of a Type UB III, the UB-86, shown abandoned and grounded after World War I.

Similarly, Fig. 7.111 shows plans for the Type VII U-boat (built 1935–1945) and a photo of a Type VII, the U-995, now on display at the Laboe Naval Museum. One can see that the Type VII was essentially an updated version of the older Type UB III design.

Figure 7.112 presents plans for the much more advanced Type XXI U-boat (built 1943–1945) and shows three Type XXI U-boats at the German naval base at Bergen, Norway. Figures 7.113–7.118 are photographs of a Type XXI, the U-2540 “Wilhelm Bauer,” now on display at the German Maritime Museum in Bremerhaven. The Type XXI submarine design was so advanced for its time that the Allies considered it an extremely serious threat, even very late in the war. For example, the 12 January 1945 Top Secret Cable OUT 1005 from Office of Strategic Services Magruder to Bern Switzerland [NARA RG 226, Entry UD-90, Box 7, Folder BERN—IN OUT 1944–1945] stated:

German program for new type submarines is perhaps most menacing aspect of German war capabilities due to exceptional defensive characteristics of new submersibles. At present only effective defense is to interfere with their production. I refer to types Roman number 21 and 23. Former of 1600 tons and latter of 200 tons plus. The 21 is particularly dangerous. Both are prefabricated in various places and shipped in parts to launching ports. Productive capacity and assembly speed high.

Please give priority to information permitting air attack on places of manufacture of prefabricated hulls and routes to assembly ports. Also much desired is place of manufacture of new and highly efficient types of Diesel engines and batteries.

### Some key submarine designers

**Christoph Aschmoneit  
(1901–1984)**



**Gustav Berling  
(1869–1943)**

**Fritz Bröking  
(1877–1961)**



**Ulrich Gabler  
(1913–1994)**



**Friedrich Schürer  
(1881–1948)**



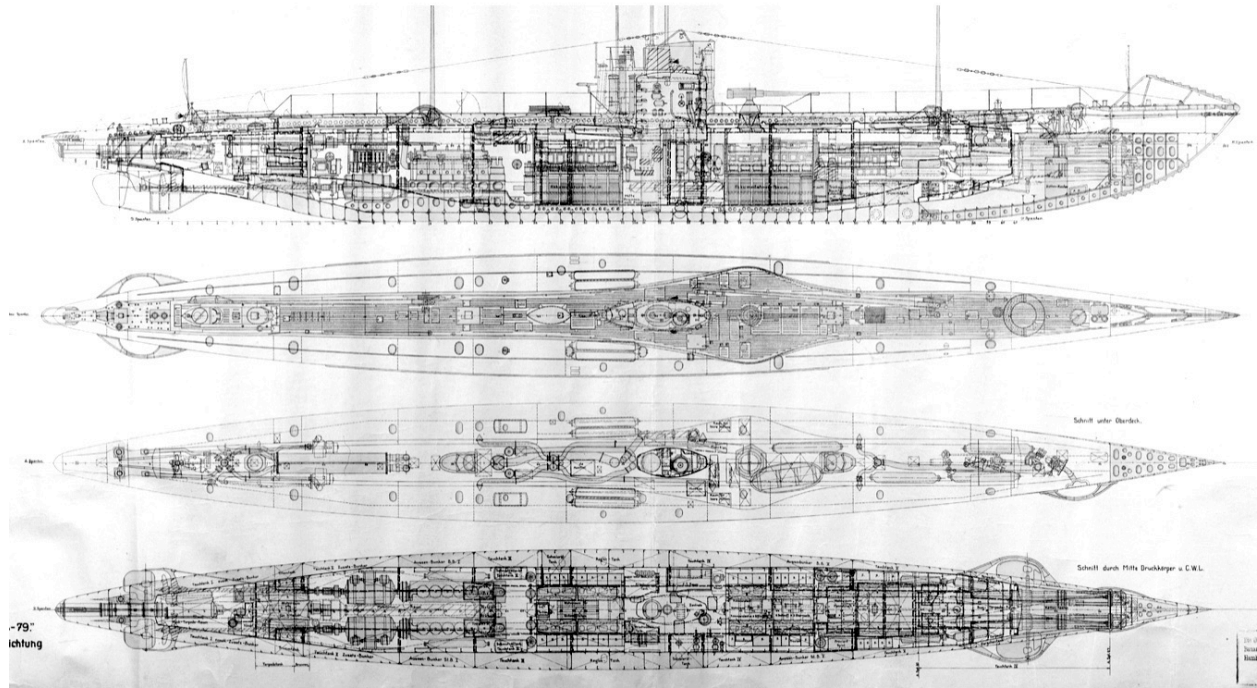
**Hellmuth Walter  
(1900–1980)**



Figure 7.109: Some key submarine designers included Christoph Aschmoneit, Gustav Berling, Fritz Bröking, Ulrich Gabler, Friedrich Schürer, and Hellmuth Walter.



## Type UB III U-Boat (1915–1918)



## UB-86 Type UB III submarine grounded after World War I

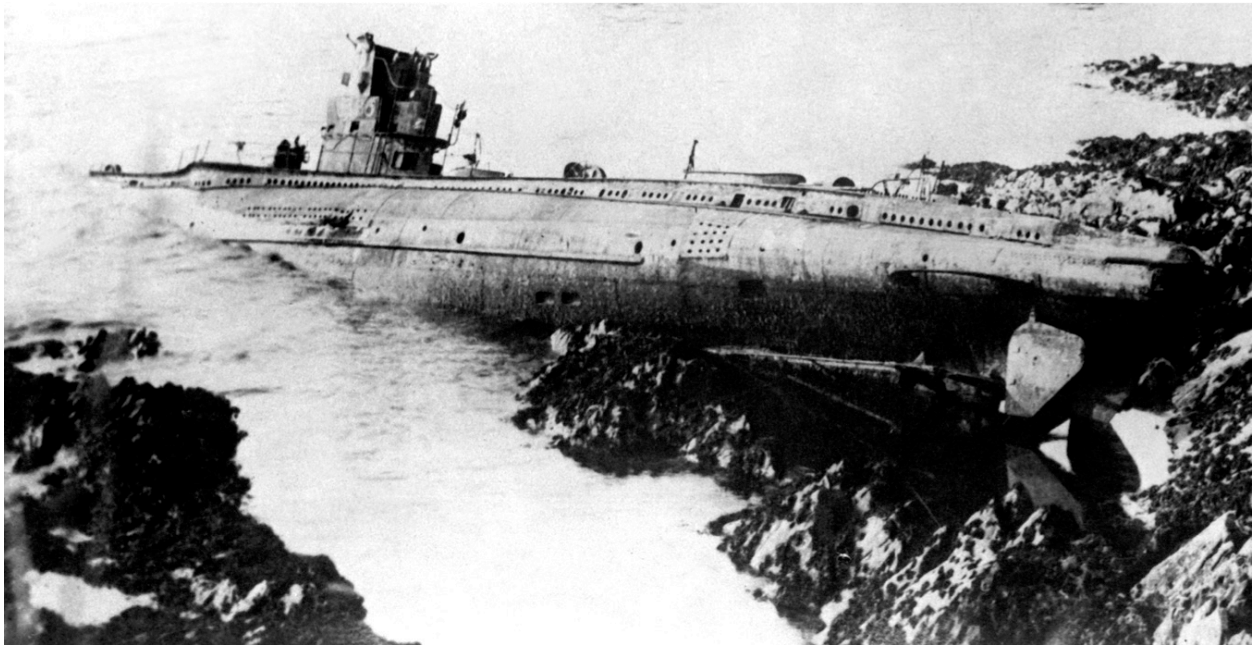
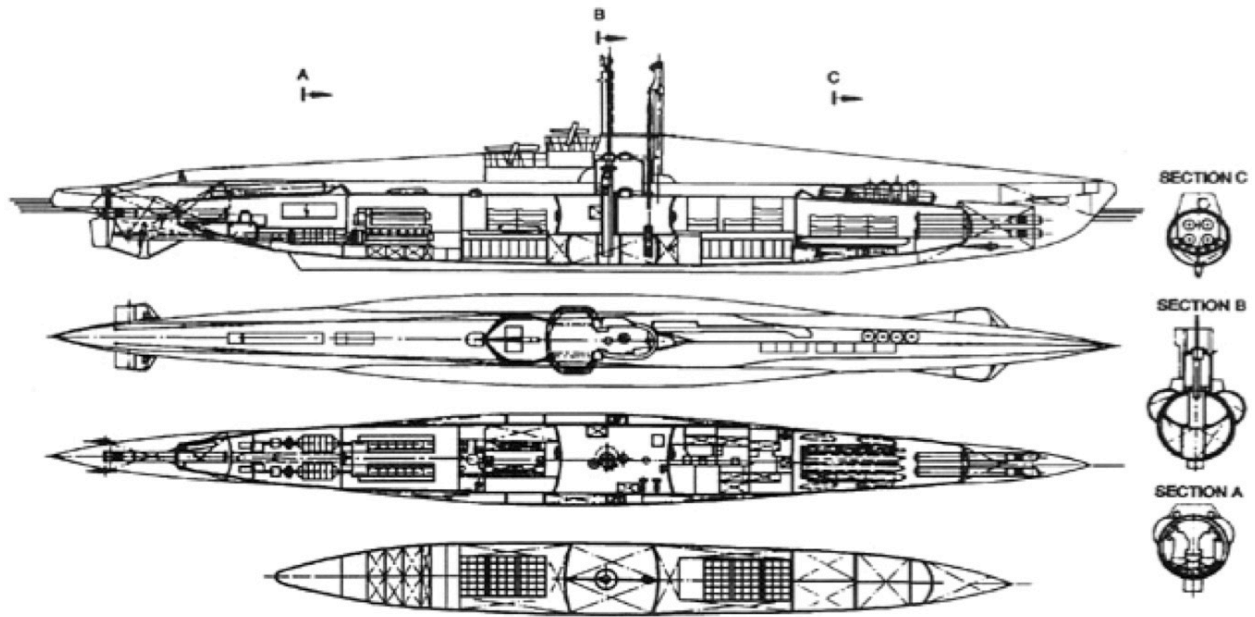


Figure 7.110: Plans for the Type UB III U-boat (built 1915–1918), and a Type UB III, the UB-86, abandoned and grounded after World War I.

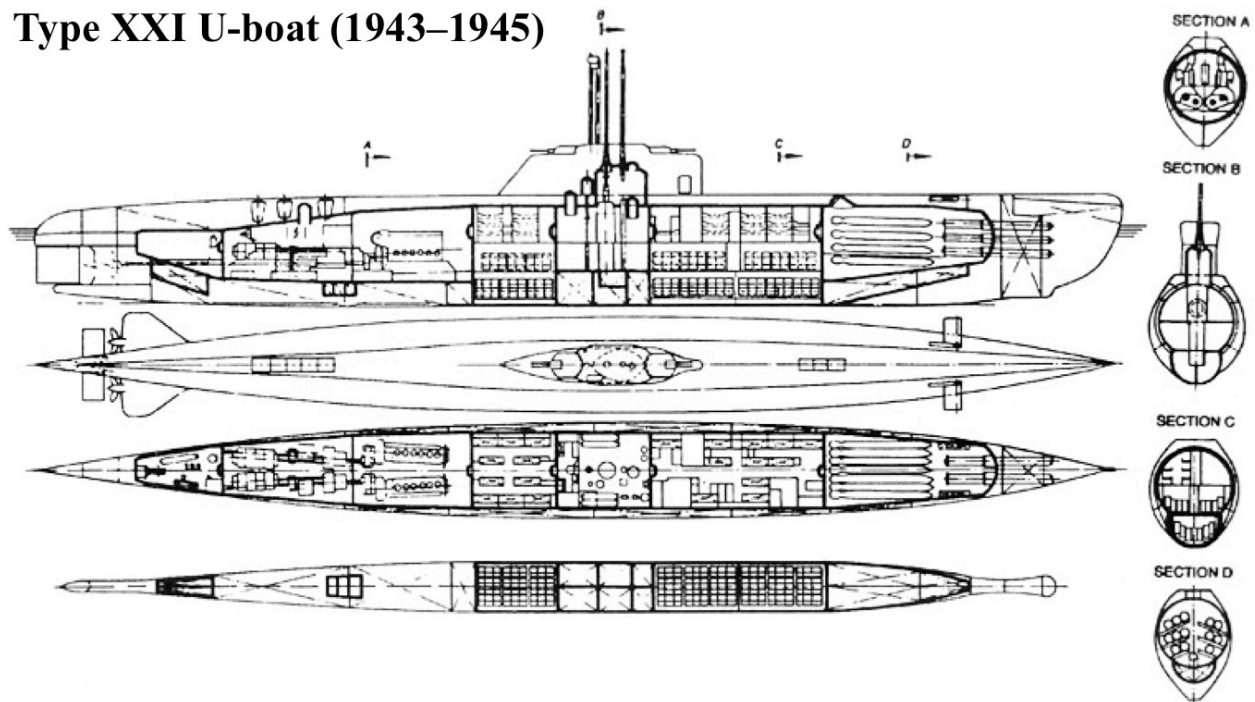
## Type VII U-boat (1935–1945)



## U-995 Type VII, Laboe Naval Museum



Figure 7.111: Plans for the Type VII U-boat (built 1935–1945), and a Type VII, the U-995, now on display at the Laboe Naval Museum.

**Type XXI U-boat (1943–1945)**

**Three Type XXI U-boats and one Type VII U-boat (far left)  
at Bergen, Norway (May 1945)**

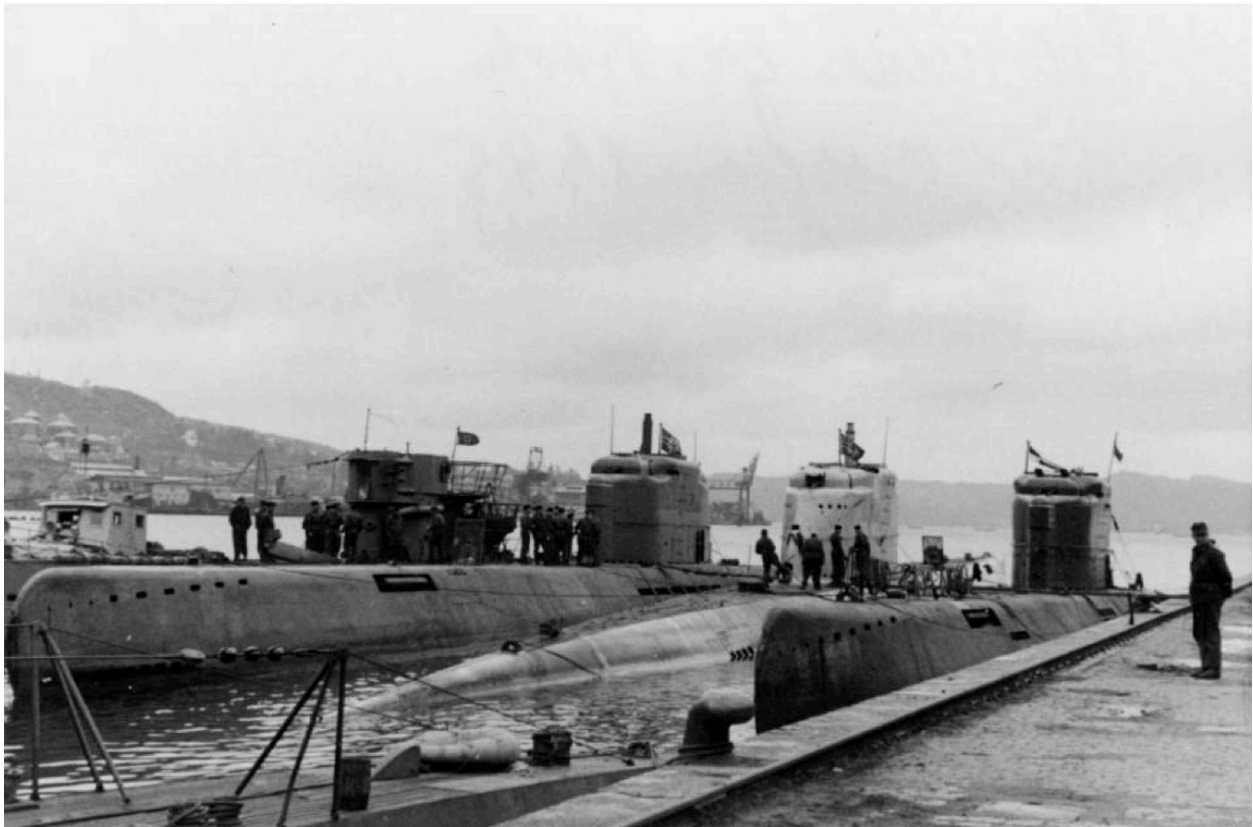


Figure 7.112: Plans for the Type XXI U-boat (1943–1945), and three Type XXI U-boats and one Type VII U-boat at Bergen, Norway (May 1945).





**Type XXI U-boat, U-2540 *Wilhelm Bauer*,  
German Maritime Museum, Bremerhaven**



Figure 7.113: A Type XXI submarine, the U-2540 *Wilhelm Bauer*, now on display at the German Maritime Museum in Bremerhaven.





Figure 7.114: The engine room and the batteries of the U-2540 submarine.



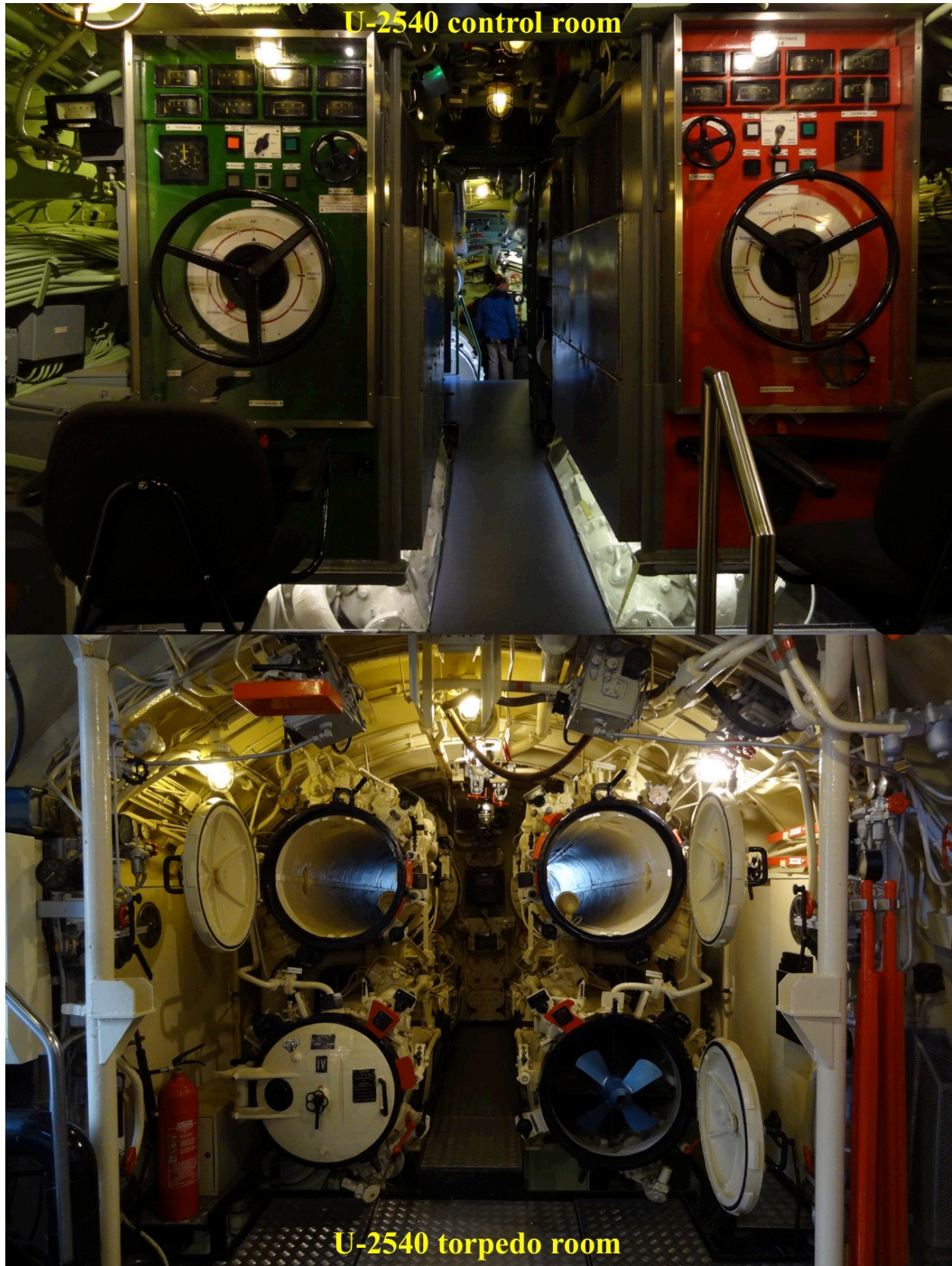
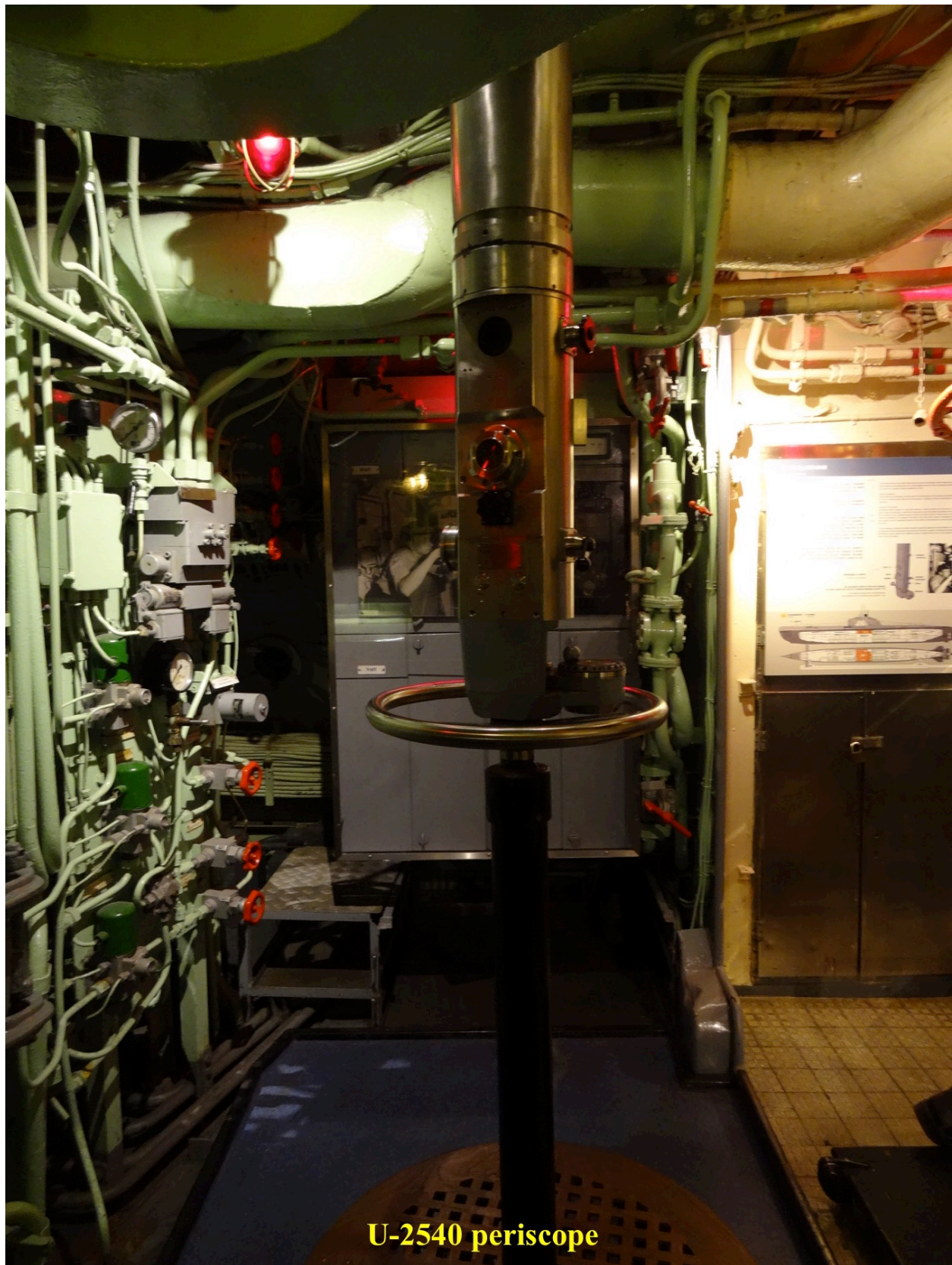


Figure 7.115: The control room and the torpedo room of the U-2540 submarine.





**U-2540 periscope**

Figure 7.116: The periscope of the U-2540 submarine.





Figure 7.117: The ladder to the conning tower in the U-2540 submarine.





**U-2540 crew bunks**

Figure 7.118: One of the cabins with crew bunks in the U-2540 submarine.



Of the 123 Type XXI U-boats in service during the war, 23 were destroyed by Allied attacks and 88 were scuttled by Germany at the end of the war. After the war, the remaining 12 operational Type XXI submarines were divided among the U.S., U.K., France, and Soviet Union and studied very closely (Fig. 7.119) [Breyer 1999, p. 38; Wetzel 1999; NYT 1945-11-22 p. 16a, 1947-02-12 p. 10]. As just one example, on 12 February 1947, the *New York Times* reported:

The House Armed Services Committee gave unanimous approval today to construction of two new experimental submarines embracing ideas gained from Allied war experiences and seized German U-boats. It approved, subject to House action next week, the Navy's request for authority to spend up to \$30,000,000 in already appropriated funds to build the new vessels. The estimated cost of each submarine is from \$11,000,000 to \$15,000,000.

U.S. submarine experts Norman Polmar and Kenneth Moore confirmed that postwar submarines in the United States, Soviet Union, and other countries were based directly on the captured German submarine technology [Polmar and Moore 2004, p. xi]:

Soviet and U.S. submarines of the Cold War era had the same origins: Their antecedents were German U-boat developments of 1943–1945, especially the Type XXI, the most advanced submarine to go to sea during World War II. The U.S. version of the Type XXI was the *Tang* (SS 563) class, with similar features being incorporated in the *K1*-class “killer” submarines and 52 conversions of war-built submarines in the so-called GUPPY program. The Soviets adopted Type XXI features in the Whiskey and Zulu designs and their successors. The U.S. and Soviet (as well as British) submarine communities also had major interest in German closed-cycle, or “single-drive,” submarine propulsion systems, with these submarines being evaluated in the postwar period by Britain and the Soviet Union.

Wartime prototype submarines that utilized a teardrop hull design for high speeds included the V-80 (first demonstrated in 1940) and the *Delphin* (*Dolphin*, first demonstrated in 1944); see Fig. 7.120. Of course, the teardrop design was known much earlier from German airship designs (see Section 9.1). The teardrop hull is sometimes called the *Albacore* hull after the first U.S. submarine to use that shape, the USS *Albacore*, which was designed using captured German submarine designs and launched in 1953.

As illustrated in Fig. 7.121, the United States needed German machines (such as the Trebel balancing machine shown in the photo) in order to make propellers for its postwar submarines such as *Nautilus*, the first U.S. nuclear submarine [NYT 1958-10-09 p. 73].

As shown in Fig. 7.122, a recently declassified CIA report from 1950 (summarizing Soviet work from 1943 to 1948) reveals how dependent postwar Soviet submarines were on captured German-speaking scientists and submarines, torpedoes, missiles, and other technologies from wartime German programs [<https://www.cia.gov/readingroom/document/cia-rdp80-00809a000600360061-4>].

# Truman Dives 440 Feet in German Sub

Intends to Let Law  
Take Course on Lewis

KEY WEST, Fla., Nov. 21 (UP)—President Truman today made a 440-foot dive beneath the surface of the Atlantic Ocean in a former German submarine.

He was the first President of the United States ever to make such a trip beneath the ocean. Mr. Truman saw one of Germany's biggest war secrets—the "schnorkel" type U-boat—in operation.

The coal strike brought no variation in the President's holiday schedule. Members of his staff said he intended to let the law take its course in the Government's battle with John L. Lewis.

Aboard the U-2513, Mr. Truman had breakfast at sea before the officers of the Navy's submarine base here dived the ship and demonstrated her equipment.

Mr. Truman came back from his four-hour submarine trip highly enthusiastic about the teamwork so necessary to any undersea operation.

During the cruise, the President saw the schnorkel breathing device in operation. This is a tube-like device reaching the surface. It permits a submarine to remain submerged almost indefinitely.

After the submarine cruise, the President returned to his quarters here to await an up-to-the-minute report on the coal strike. His counsel, Clark M. Clifford, who is with the Chief Executive here, received reports from Washington by telephone.

As the sub came back to port, the President was made a member of "The Royal Order of Deep Dunkers," an organization of submariners.

President Harry Truman visiting  
the U-2513 Type XXI submarine

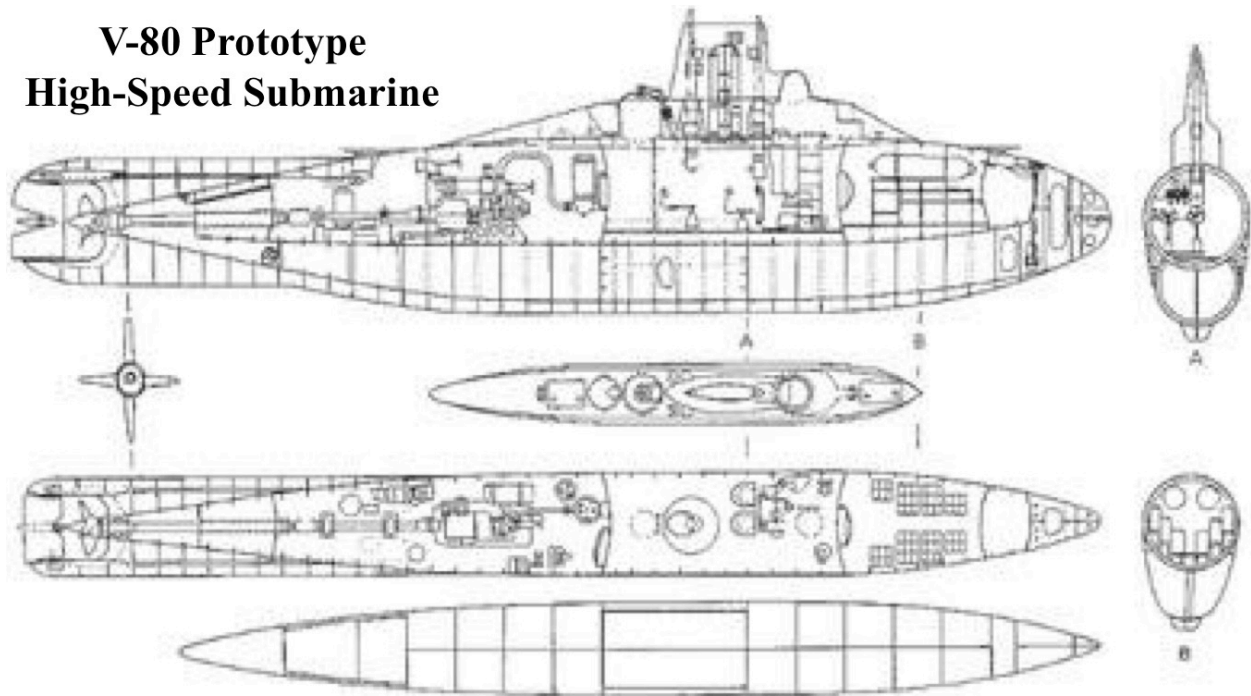
*The Pittsburgh Press,*  
21 November 1946, p. 9

Admiral William Leahy on the  
U-2513 Type XXI submarine



Figure 7.119: In 1946, President Harry Truman and Admiral William Leahy visited a captured Type XXI submarine, U-2513, that was being intensively studied by the U.S. Navy [*Pittsburgh Press*, 21 November 1946, p. 9; <http://www.navsource.org/archives/08/08358.htm>].

### V-80 Prototype High-Speed Submarine



**V-80  
(1940)**



**Delphin  
(1944)**

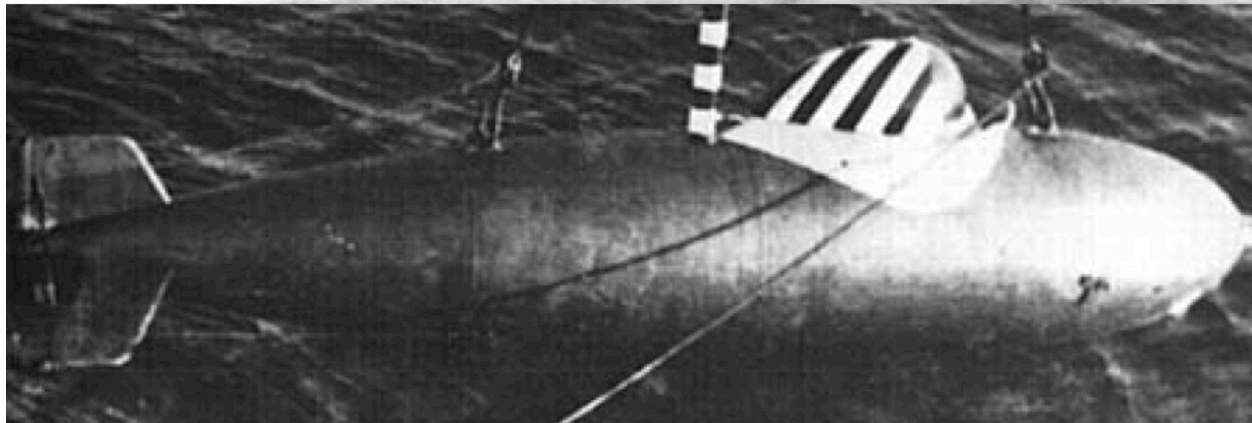
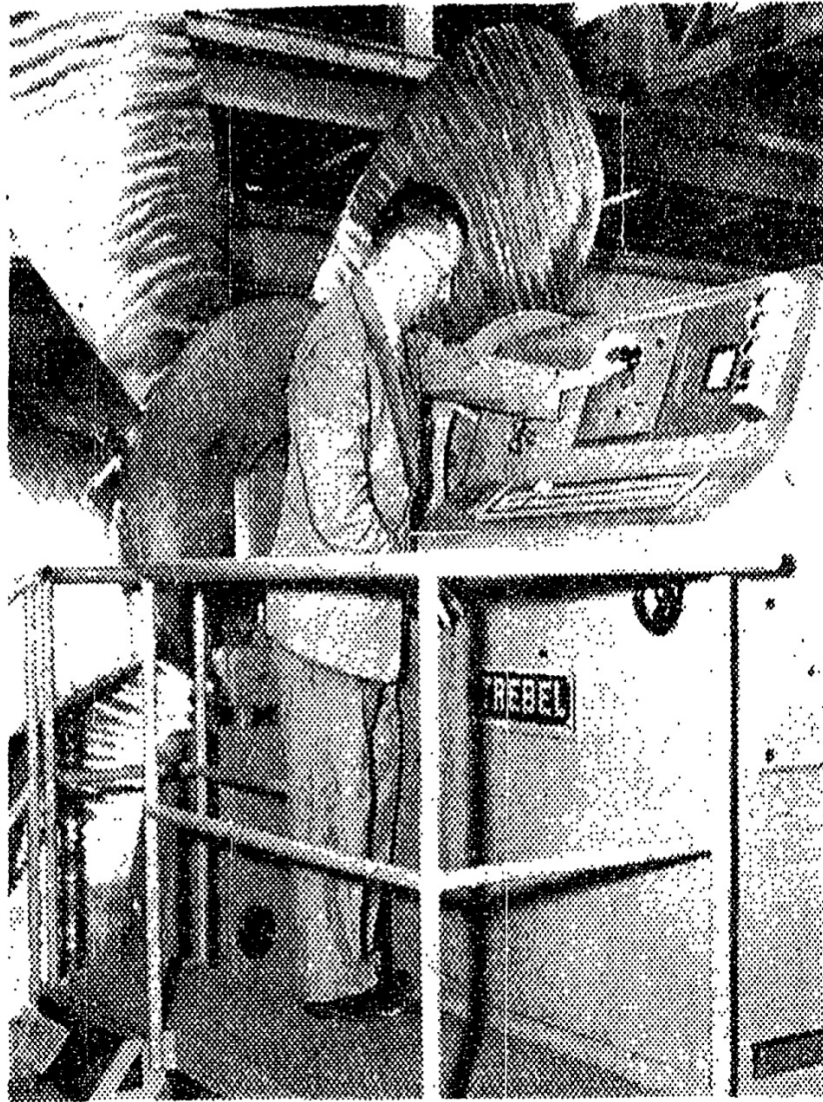


Figure 7.120: Prototype submarines that utilized a teardrop hull design for high speeds included the V-80 (first demonstrated in 1940) and the Delphin (Dolphin, first demonstrated in 1944).



## ***Plant That Built Nautilus Wheel Ready for Other Big Propellers***

*New York Times*, 9 October 1958, p. 73



An engineer of Columbian Bronze Corporation, at console of balancing machine, prepares to test propeller at left for imbalance. Such imperfection would show on scale.

---

## ***Freeport Plant Gets 2 German Machines That Speed Making and Repairing on a Regular Production Basis***

Figure 7.121: The United States needed German machines to make propellers for its postwar submarines such as *Nautilus*, the first U.S. nuclear submarine [NYT 1958-10-09 p. 73].

**SECRET**

SECRET

50X1-HUM

In the USSR, submarine construction, together with aircraft construction further development of the V-2 rocket, and the development of a practicable atomic bomb, is a priority project of the armament industry. Prior to the war, the Russian built, at Leningrad, only the standard type submarine of 900 tons displacement, not counting a few experimental types. Only after the war, when the Russians had occupied Berlin and the German Baltic ports and had obtained the German design data and ships, did they take up submarine construction intensively. In 1946, the Russians succeeded in getting a number of the members of the staff of the Glueckauf Engineering Office at Blankenburg in the Harz Mountains -- during the war the central designing office for German submarines -- to return there by offering them high salaries. The construction of the German Type 26 submarine, the so-called Walther submarine, was then resumed. Some of the Blankenburg staff later went to Koenigsberg and to Leningrad, others returned to the Western zone.

The captured U-boats were concentrated at Leningrad and at Kronshtadt. The Russians are working on further development of the German Type 21 submarine. In the summer of 1948, about 15 submarines of this type were under construction at the Leningrad Navy Yard. An interesting improvement instituted by the Russians is the quick-loading mechanism of the bow torpedo tubes. The German quick-loading mechanism did not function properly, but the Russians have improved it to such an extent that all six tubes in the box can now fire three times within 3 minutes.

The Russians are also experimenting with the installing of rocket launchers on Type 21 submarines. The launcher resembles a torpedo tube. It is set up in front of the conning tower, and operated from inside the ship. It will still function when the ship is submerged to half the height of the conning tower. The rockets are powered by liquid fuel, consisting of a hydrocarbon -- nitric acid mixture with automatic ignition. Fuel feed is by compressed air. The rockets have a range of about 7 kilometers, and their accuracy is adequate.

At Odessa, the Russians are building two-man submarines developed from the German design. They are powered by a high-rpm diesel engine. The captain of the submarine can stand up on his seat when the ship is surfaced, and the upper part of his body protrudes from the conning tower. The engineer sits in front of the engine, and can start the engine with a hand crank, in case the battery is run down and no longer has enough power to operate the self-starter. The tower is equipped with a short periscope which is retractable. The submarine carries two torpedoes underneath the hull. This type of submarine is manned only by volunteers. It is capable of a speed of about 12 nautical miles.

The Russians are testing three new types of torpedoes. The first is the well-known acoustic torpedo, which is automatically attracted to the target by the noise of the target's propellers. This version has been developed to a high degree of perfection, and possesses high accuracy. Of course, it still suffers from the disadvantage that the target can tow noise-producing dummies which will deflect the torpedo, provided they operate in the proper frequency range.

The second version used ultrasonic guide beams. The frequency is in the range of 800 kc. The results obtained with this torpedo were very satisfactory up to a distance of 3 nautical miles. The torpedo is not very susceptible to jamming, unless the jamming is tuned exactly to the guide-beam frequency. At large distances, the guidance becomes less reliable, because it is difficult to produce ultrasonic waves at that frequency with a sufficiently large range.

The third version employs infrared radiation for automatic steering, and uses the principle of radar. This design was first developed by the Germans toward the end of the war and then perfected by the German engineers for the Russians. The torpedo is very accurate, even at long ranges, provided the infrared ray generator functions properly. Since this is not always the case, 35 percent of the torpedoes misfire.

- 4 -

SECRET

**SECRET**

Figure 7.122: A recently declassified CIA report reveals how dependent postwar Soviet submarine technologies were on German-speaking innovators and innovations. New Soviet Weapons. 10 November 1950 [based on intelligence from 1943-1948]. <https://www.cia.gov/readingroom/document/cia-rdp80-00809a000600360061-4>.

The key features of modern naval mines and torpedoes were developed by creators from the German-speaking world.<sup>10</sup>

While the concept of naval mines had been around for centuries, the chief difficulty was making the mines detonate automatically and reliably, without direct human control or timers. That problem was solved by German inventors in the nineteenth century, as shown in Fig. 7.123. The first practical contact-activated naval mines were created by Moritz von Jacobi (German, 1801–1874) in 1853. His mines used electromechanical contact switches, and they were successfully employed during the Crimean War.

In 1868, Albert Hertz (German, 18??–19??) invented improved mines that used electrochemical contact switches, or “Hertz horns.” Inside each metal horn was a fragile glass reservoir of liquid electrolyte; if the horn was bumped, the liquid electrolyte was released into the previously empty space between two electrodes, making a functional electrical battery that detonated the mine. That was a very simple and elegant solution that allowed a deployed naval mine to remain viable for many years. Even in the twenty-first century, many naval mines still use this method.

Self-propelled explosive torpedoes were developed in the 1850s–1860s by a currently unknown Austrian marine artillery officer, Giovanni Luppis von Rammer (Austro-Hungarian/Croatian, 1813–1875), Robert Whitehead (English but worked in Austria, 1823–1905), and Annibale Plösch (Austrian, 1826 or 1836–1906?). See Fig. 7.124. Using their designs, the world’s first torpedo factory opened in 1872 in Fiume, Austro-Hungary (now Rijeka, Croatia; Fig. 7.125).

Nikola Tesla (Serbo-Croatian, educated in Austria, 1856–1943) made a revolutionary early advance when he patented and demonstrated a radio-controlled boat or torpedo in 1898 (p. 1207). Building on that invention, Siemens engineers developed the Fernlenkboot remote-controlled explosive motorboat/torpedo in 1911 (Fig. 7.126). Fernlenkboot models came in both radio-controlled and wire-guided versions, carried 700 kg of explosives, could travel up to 56 km/hour, had a range of up to 20 km, and were successfully employed during World War I.

German-speaking creators made numerous other improvements to torpedoes before, during, and after World War I. By World War II, German innovations in torpedo design included improved energy sources such as batteries (in G7e torpedoes) and concentrated hydrogen peroxide ( $H_2O_2$ , called Ingolene). Other innovations included improved guidance systems such as preprogrammed pattern running systems (Fat I/II and Lut I/II) and acoustic homing systems (Falke and Zaunkönig). Those innovations in torpedo design were adopted by other countries after the war.<sup>11</sup> See Fig. 7.127.

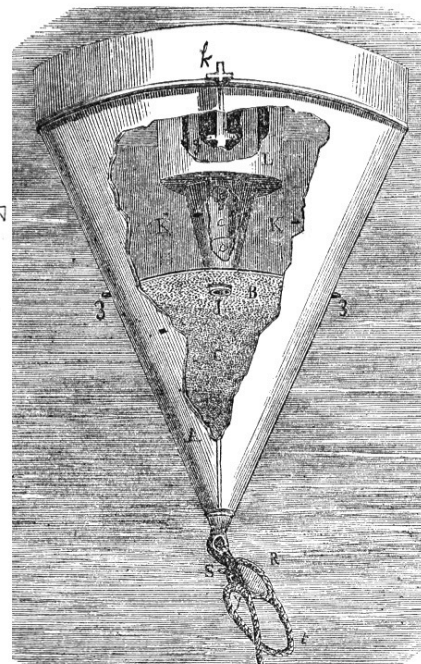
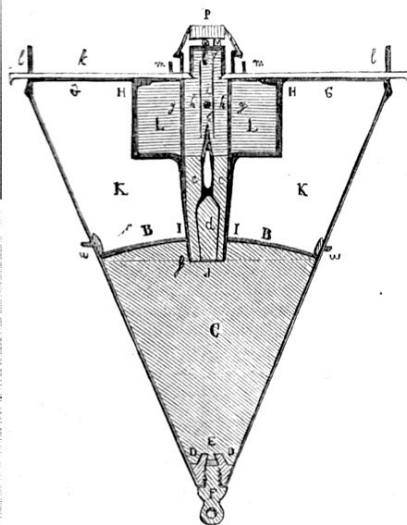
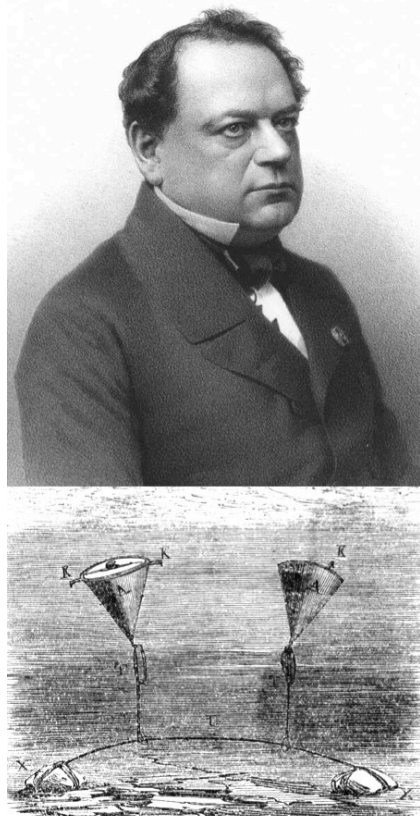
---

<sup>10</sup>Cowie 1949; Hartmann and Truver 1991; Hussey 1946; Jolie 1978; Eberhard Rössler 2005.

<sup>11</sup>Eberhard Rössler 2005; CIOS XXXII-69; NavTecMisEu LR 78-45; NavTecMisEu LR 79-45; NavTecMisEu LR 80-45; NavTecMisEu 161-45; NavTecMisEu 202-45; NavTecMisEu 203-45; NavTecMisEu 204-45; NavTecMisEu 205-45; NavTecMisEu 206-45; NavTecMisEu 207-45; NavTecMisEu 208-45; NavTecMisEu 209-45; NavTecMisEu 211-45; NavTecMisEu 356-45.



**Moritz von Jacobi (1801–1874)**  
**invented naval mines activated by**  
**electromechanical contact switches (1853)**



**Albert Hertz (18??–19??) invented naval mines activated**  
**by electrochemical contact switches or “Hertz horns” (1868)**



Fig. 1. Kontakt-Torpedo

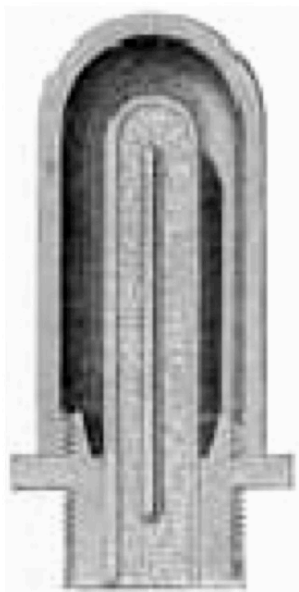


Fig. 2.  
 Chemisch wirkender  
 Zünder des Kontakt-  
 Torpedos.



Figure 7.123: The first practical contact-activated naval mines were created by Moritz von Jacobi (1853, using electromechanical contact switches) and Albert Hertz (1868, using electrochemical contact switches).

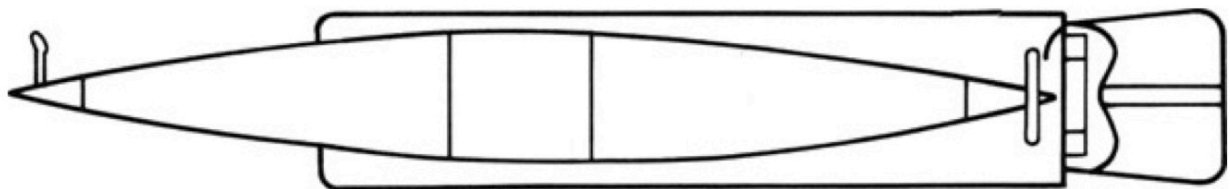
**Torpedoes (1850s–1860s)****Original inventor: Austrian marine  
artillery officer—name??? (18??–18??)****Giovanni Luppis  
von Rammer  
(1813–1875)****Robert Whitehead  
(1823–1905)****Annibale Plöch  
(1826/36–1906?)**

Figure 7.124: Torpedoes were developed in the 1850s–1860s by a currently unknown Austrian marine artillery officer, Giovanni Luppis von Rammer, Robert Whitehead (working in Austria), and Annibale Plöch.



**The world's first torpedo factory opened in 1872  
in Fiume, Austro-Hungary (now Rijeka, Croatia)**

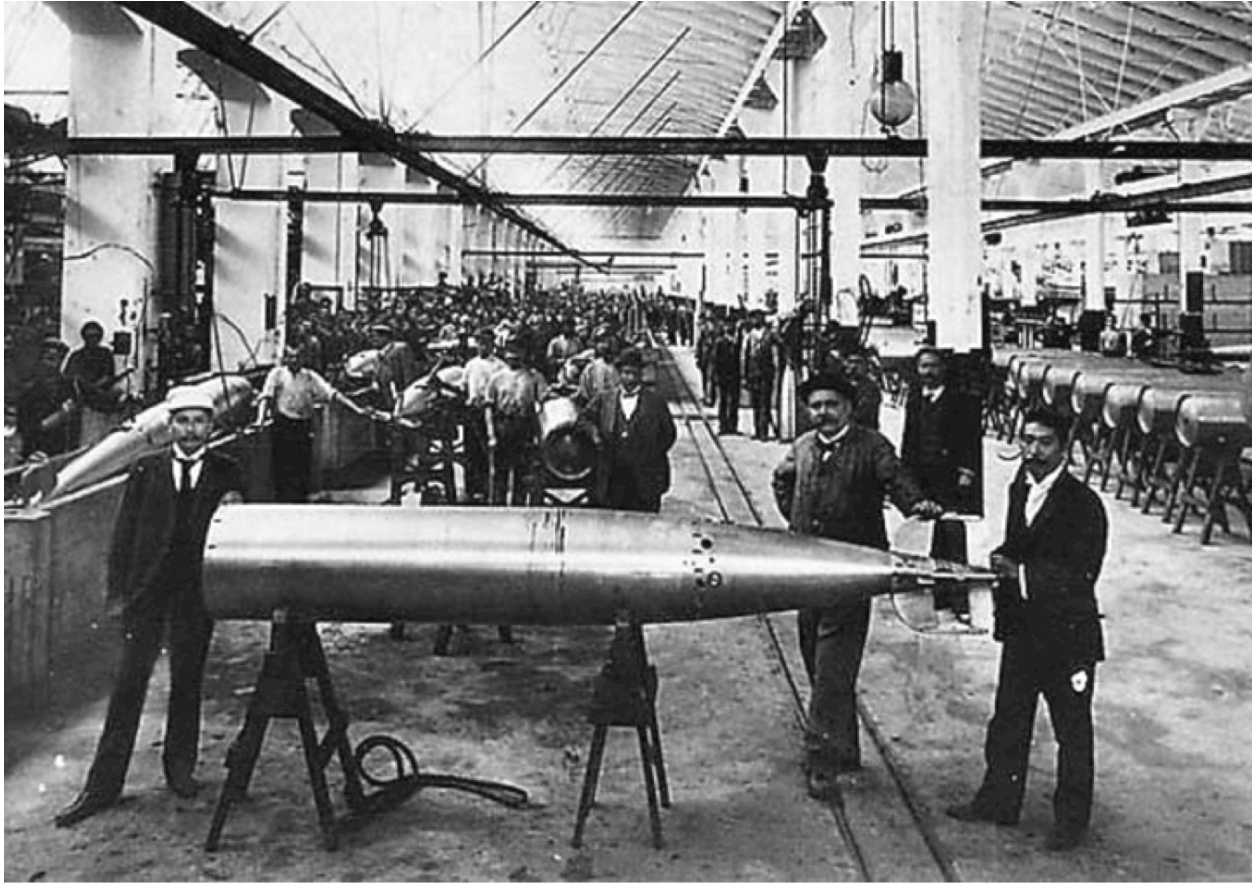


Figure 7.125: The world's first torpedo factory opened in 1872 in Fiume, Austro-Hungary (now Rijeka, Croatia).



### Siemens Fernlenkboot explosive motorboat/torpedo (1911)

**Both radio-controlled and wire-guided versions were built and used**

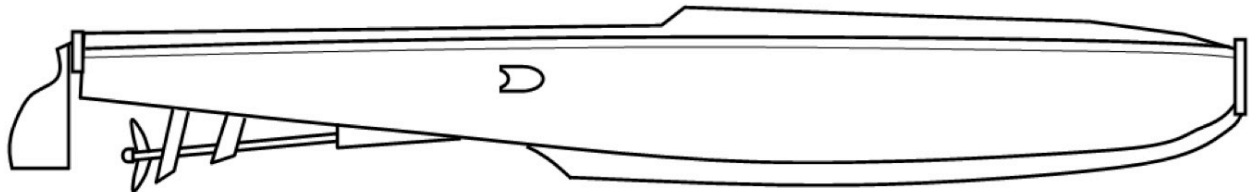


Figure 7.126: In 1911, Siemens engineers developed the Fernlenkboot explosive motorboat/torpedo, available in both radio-controlled and wire-guided versions. It was successfully employed during World War I.

## Advanced torpedoes

### Improved energy sources:

- Batteries (G7e)
- Hydrogen peroxide (Ingolene)

### Improved guidance systems:

- Pattern running (Fat, Lut)
- Acoustic homing (Falke, Zaunkönig)



Figure 7.127: Some German innovations in torpedo design included improved energy sources such as batteries (in G7e torpedoes) and concentrated hydrogen peroxide ( $H_2O_2$ , called Ingolene). Other innovations included improved guidance systems such as preprogrammed pattern running systems (Fat I/II and Lut I/II) and acoustic homing systems (Falke and Zaunkönig).

German submarine bunkers were also quite sophisticated. For example, as shown in Fig. 7.128, the U-boat bunker Bruno in Bergen, Norway could hold and service up to nine submarines at a time, with six meters of overhead concrete reinforcement to protect them from Allied aerial bombing.

The Goliath low-frequency radio transmitter (Kalbe/Calbe an der Milde) could communicate with submerged submarines around the world. The transmitter was essentially a spiderweb of antennas that stretched 1600 m wide and 200 m high. Once it became operational in 1943, it radiated one million Watts of electromagnetic power [Bauer 1997; Klawitter 1998; AFHRA B1975, frames 1325–1495; <https://www.kalbe-milde.de/gol.php>]. See pp. 1476–1478. After the war, the Goliath transmitter was extensively studied by western Allied countries and completely removed by and reconstructed in the Soviet Union, inspiring postwar low-frequency radio transmitters for submarine communications in many countries. For example, the U.S. Navy’s similar Clam Lake facility in Wisconsin became operational in 1985 (Fig. 7.132).

An especially mysterious and historically important topic is how far wartime Germany may have gotten in developing nuclear power for submarine propulsion, and how much that work influenced and aided postwar work on nuclear submarine propulsion in the United States and other countries. It seems very likely that there was such a wartime program, since Germany was very interested both in developing fission reactors (Appendix D) and also in improving the performance of its submarines (which were limited by needing air to power their diesel engines, except for short periods of fully submerged operation using batteries). Unfortunately there is very little available documentation at present. One intriguing comment long after the war came from Werner Grothmann, who had been Heinrich Himmler’s chief adjutant [Krotzky 2002, p. 34; see pp. 3396–3397 regarding this source]:

Deshalb kann ich auch nichts dazu sagen, was im einzelnen auf Bornholm war, außer daß auch die Kriegsmarine dort etwas machte. Vielleicht mit der Reichspost zusammen. An den Vorüberlegungen zum Atommotor für unsere U boote werden sie dort nicht gearbeitet haben, das lief ja in Berlin bei Rhein und der hatte sich dazu Physiker ausgeliehen, die auch mal beim Heereswaffenamt unter Vertrag standen, aber jedenfalls nicht bei der Reichspost.

That is why I cannot say anything in detail about what was on Bornholm, except that the German Navy did something there as well. Maybe together with the Reichspost. They would not have worked there on the preliminary considerations for the atomic engine for our submarines; that ran in Berlin with [Admiral Wilhelm] Rhein and he had borrowed physicists, who were also under contract with the Army Ordnance Office, but in any case not with the Reichspost.

Admiral Wilhelm Rhein headed the Navy Weapons Office (Marinewaffenamt, MWA) in Berlin. He assembled a team of scientists (including Otto Haxel, Pascual Jordan, Helmut Hasse, Fritz Houtermans, and others) that worked on applications of nuclear technology for the German navy. Because so few documents from those programs survive (or have been declassified if they do survive), it is currently unclear just how far those programs progressed by the end of the war.

Nonetheless, it is quite intriguing that the zirconium (and possibly other materials, information, and/or expertise) for the first postwar U.S. nuclear submarine was left over from a mysterious wartime German program. See p. 4146–4147 for more information.





**U-boat bunker Bruno in Bergen, Norway (circa 1944)**

**U-boat bunker Bruno in Bergen now (huge weathered concrete structure behind the black Rolls Royce building)**



Figure 7.128: The U-boat bunker Bruno in Bergen, Norway could hold and service up to nine submarines at a time, with six meters of overhead concrete reinforcement to protect them from Allied aerial bombing.

**Goliath low-frequency radio transmitter to communicate  
with submarines (Kalbe an der Milde, operational in 1943)**

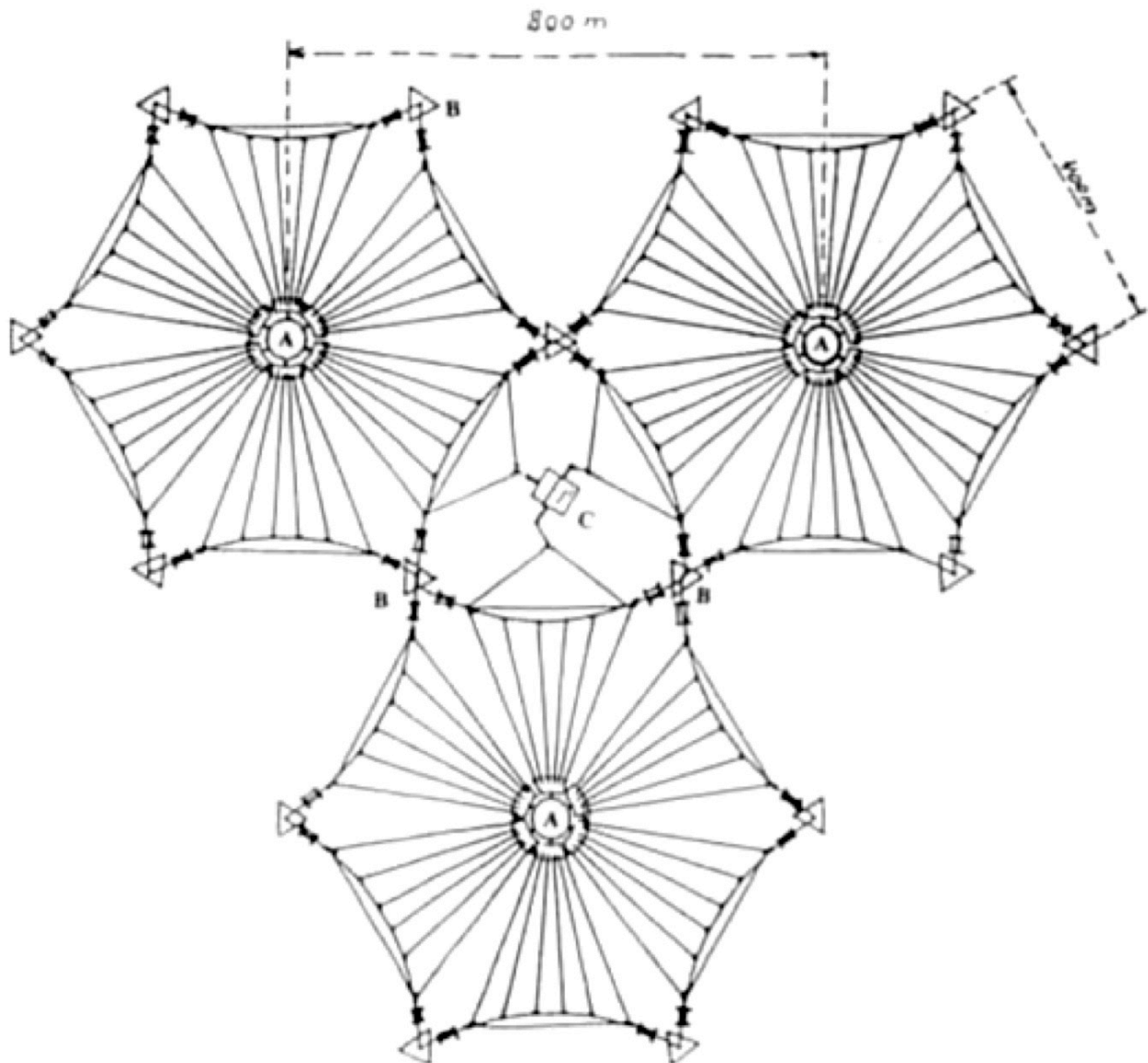


Figure 7.129: The Goliath low-frequency radio transmitter (Kalbe/Calbe an der Milde) could communicate with submerged submarines around the world. It was 1600 m wide and 200 m high, radiated one million Watts of electromagnetic power, and became operational in 1943.

**Goliath low-frequency radio transmitter to communicate with submarines (Kalbe an der Milde, operational in 1943)**



Figure 7.130: The Goliath low-frequency radio transmitter (Kalbe/Calbe an der Milde) could communicate with submerged submarines around the world. It was 1600 m wide and 200 m high, radiated one million Watts of electromagnetic power, and became operational in 1943.



**Goliath low-frequency radio transmitter to communicate with submarines (Kalbe an der Milde, operational in 1943)**

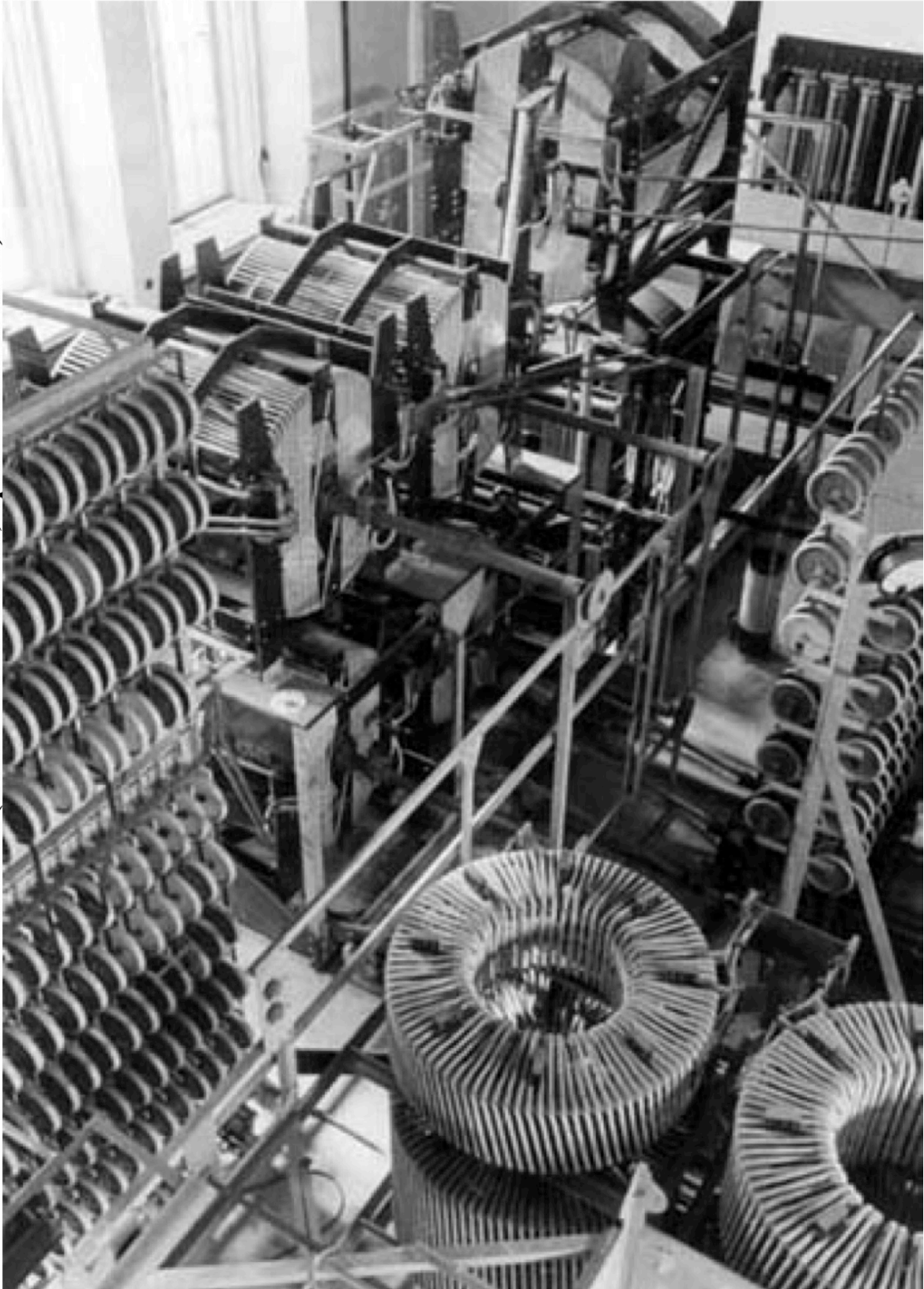


Figure 7.131: The Goliath low-frequency radio transmitter (Kalbe/Calbe an der Milde) could communicate with submerged submarines around the world. It was 1600 m wide and 200 m high, radiated one million Watts of electromagnetic power, and became operational in 1943.

**U.S. low-frequency radio transmitter to communicate with submarines (U.S. Navy's Clam Lake facility, Wisconsin, operational in 1985)**



Figure 7.132: Inspired by the wartime German Goliath transmitter, other countries later built similar massive low-frequency radio transmitters to communicate with submerged submarines around the world. For example, the U.S. Navy's Clam Lake facility in Wisconsin became operational in 1985. The Soviet Union used the Goliath transmitter itself, disassembled and reassembled by German experts in the Soviet Union.



At the very least, it is clear that wartime Germany adapted gas turbine engines for use in submarines, and that those engines and methods were found and utilized by other countries after the war. For example, BIOS 98, *Report on German Development of Gas Turbines for Armoured Fighting Vehicles*, p. 78, stated:

Notes on the Interrogation of Dipl. Ing. Heinrich Holzapfel [...]

At Messrs. Bruckner-Kanis he was engaged on the development of turbines operating on the hydrogen peroxide cycle, developed by the Walther Company of Hamburg. In addition he was responsible for the development of gas turbines for torpedo boats.

For another example, see FIAT 291, *Gas Turbine Project for a Schnell Boat Developed by Blohm & Voss, Hamburg*.

In September 1945, R. P. Linstead and T. J. Betts, the British and American chairs of the Combined Intelligence Objectives Subcommittee (CIOS), listed a number of important German innovations in ocean engineering that were transferred to Allied countries after the war [AFHRA A5186 electronic version pp. 904–1026, Ch. 4, pp. 70–71]:

The Germans had developed submarines which were capable of underwater operation for sustained periods. It was discovered that one German submarine had operated for 40 days without surfacing. This was possible because of the “Schnorkel” which permitted the charging of batteries and the operation of engines while submerged. The “Schnorkel” is a tube-like device extending to the surface while the submarine hull is under water, thereby permitting air intake and exhaust discharge.

Much research had been devoted to closed cycle engines. These engines were intended to supplant the conventional type of Diesel, and permit underwater operation without any air intake. The Germans employed extremely high concentrations of  $H_2O_2$ , liquid oxygen, and hydrazine-hydrate as fuels. Investigation revealed that high underwater speeds were achieved by use of these fuels in conjunction with new hull designs. U-boats actually constructed obtained submerged speeds in excess of 24 knots. Submarines fully equipped could sustain a 25 knot speed for 6 hours with an underwater operating radius of 150 miles.

Intensive investigation was conducted regarding German torpedo developments. Torpedoes powered by liquid oxygen [sic: hydrogen peroxide] of 80 to 85% concentration, (Ingoline), were in large scale production. Torpedoes using this type of propulsion were capable of speeds in excess of 45 knots. It was discovered that the Germans had devised a method of employing salt water in torpedo propulsion motors, which obviated the necessity of providing fresh water tanks within the torpedo. The space and weight saving achieved enabled them to construct torpedoes capable of long ranges. Certain of these torpedoes had a range of 21,000 yards at 45 knots.

American and British naval experts have conducted detailed investigations of new German torpedo pistols.

The Germans were found to have used ultra-high boiler pressures and temperatures to attain maximum speed for surface ships, with a minimum of ship’s space devoted to power plants. [...]



Great quantities of highly classified German naval documents were obtained by US and British naval investigators. These documents included the following:

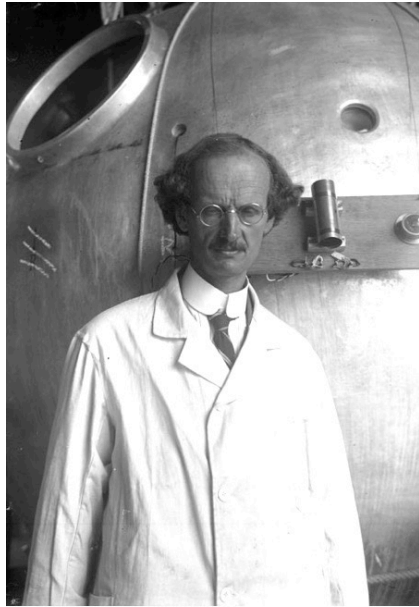
1. General specifications for the construction of ships for the German Navy; other specifications for machinery, and armament installations.
2. Complete plans for the Type 21 and Type 23 submarines and midget U-boats.
3. Plans and specifications for the latest type E-boats with the following characteristics:  
  
20 cylinder diesels, three 2500 HP motors capable of 42 knots speed, 35 meters long, 5.2 meters beam.
4. Detailed specifications for hull and machinery of the 10,000 ton Deutschland, the 6,000 ton Karlsruhe and Nuremberg, the 26,000 ton battleships Gneisenau and Scharnhorst, projected light cruisers "M" and projected battleship "O".
5. Complete specifications for the hull, machinery and armament of the 21,000 ton aircraft carrier Graf Zeppelin.

### 7.7.3 Bathyscaphes

During the period 1937–1960, Auguste Piccard (Swiss, 1884–1962), later assisted by his son Jacques Piccard (Swiss, 1922–2008), developed a series of bathyscaphes in order to carry people to extreme ocean depths, where the pressure would crush a normal submarine. See Fig. 7.133. In 1960 their *Trieste* bathyscaphe reached the deepest known part of the ocean, the floor of the Challenger Deep in the Mariana Trench, which is approximately 11 kilometers below the surface and has a pressure approximately 1100 times greater than sea-level atmospheric pressure. *Encyclopedia Britannica* explained [EB 2010]:

bathyscaphe, navigable diving vessel developed by the Swiss educator and scientist Auguste Piccard (with assistance in later years from his son Jacques), designed to reach great depths in the ocean.

The first bathyscaphe, the *FNRS 2*, built in Belgium between 1946 and 1948, was damaged during 1948 trials in the Cape Verde Islands. Substantially rebuilt and greatly improved, the vessel was renamed *FNRS 3* and carried out a series of descents under excellent conditions, including one of 4,000 m (13,000 feet) into the Atlantic off Dakar, Senegal, on Feb. 15, 1954. A second improved bathyscaphe, the *Trieste*, was launched on Aug. 1, 1953, and dived to 3,150 m (10,300 feet) in the same year. In 1958 the *Trieste* was acquired by the United States Navy, taken to California, and equipped with a new cabin designed to enable it to reach the seabed of the great oceanic trenches. Several successive descents were made into the Pacific by Jacques Piccard, and on Jan. 23, 1960, Piccard, accompanied by Lieutenant Don Walsh of the U.S. Navy, dived to a record 10,916 m (35,810 feet) in the Pacific's Mariana Trench.



**Auguste Piccard  
(1884–1962)**



**Jacques Piccard  
(1922–2008)**

**Bathyscaphes  
(1937–1960)**

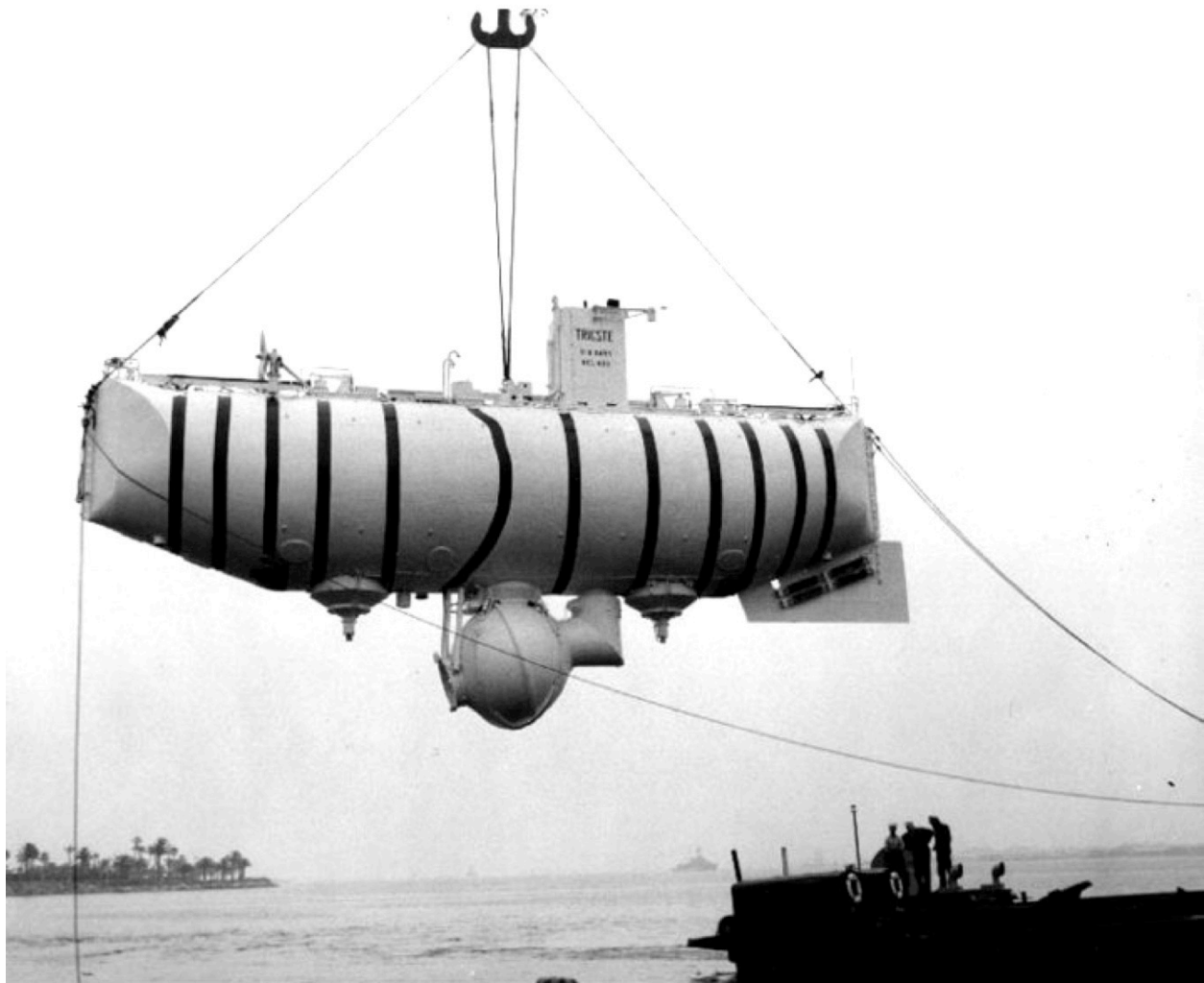


Figure 7.133: Auguste Piccard, later assisted by his son Jacques Piccard, developed a series of bathyscaphes during the period 1937–1960 in order to reach the deepest parts of the ocean.

#### 7.7.4 Rotor Ships

In 1852, Heinrich Gustav Magnus (Prussian, 1802–1870, p. 1484) described and analyzed what is now known as the Magnus effect, in which a spinning cylinder or sphere deflects incoming airflow toward one side, pushing the cylinder or sphere toward the other side. By harnessing this Magnus effect, Anton Flettner (German, 1885–1961) developed rotor ships that use spinning cylinders or rotors like sails for steering or propulsion (Fig. 7.134). Jakob Ackeret (Swiss, 1898–1981, p. 1696), Albert Betz (German, 1885–1968, p. 1665), Martin Kutta (German, 1867–1944, p. 844), and Ludwig Prandtl (German, 1875–1953, p. 1696) also played roles in analyzing the airflow around the spinning cylindrical rotors. Flettner demonstrated the first rotor ship, *Buckau*, in 1924, and a larger one, *Barbara*, in 1926.

Engineering professor Kurt Knobling described Flettner’s rotor ship innovation [Hirschel et al. 2004, p. 299]:

He aroused worldwide attention with his proposal to replace the sails of ships with upright standing perpendicular rotating cylinders, which produce, in the presence of an airflow (wind), thrust by utilizing the Magnus effect (discovered by Gustav Magnus, 1852). The Flettner experimental boats did, however, not achieve the success hoped for. In 1925, he founded his own company aiming at the application of the Flettner-rotor as wing replacement on large wind turbines. Albert Einstein appreciated Anton Flettner’s sense for utilizing physical knowledge in practical applications in his publication “My View of Life” (“Mein Weltbild”), of 1934: “*Flettner saw Ludwig Prandtl’s experiments (remark: experiments on rotating cylinders in an incoming air flow) and thought that one could use this installation to replace sails. Who knows, whether anybody else would have thought of that?*”

As shown in Fig. 7.134, rotors are still used on ships to supplement other methods and increase energy efficiency.

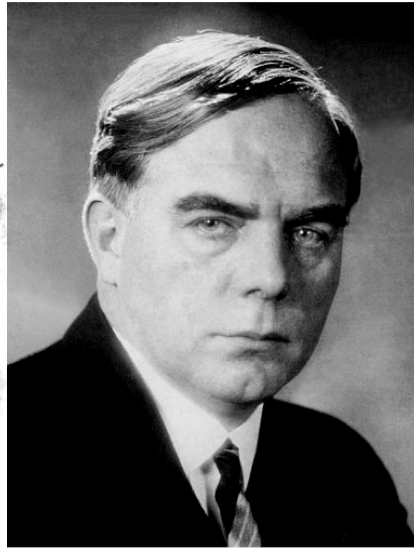
Flettner also created battlefield robots (p. 1208) and helicopters (p. 1824).



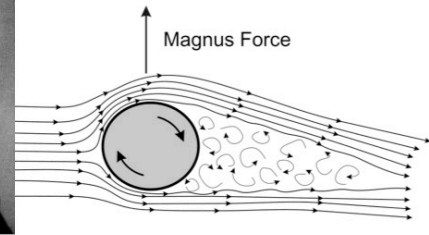
**Heinrich Gustav  
Magnus (1802–1870)**



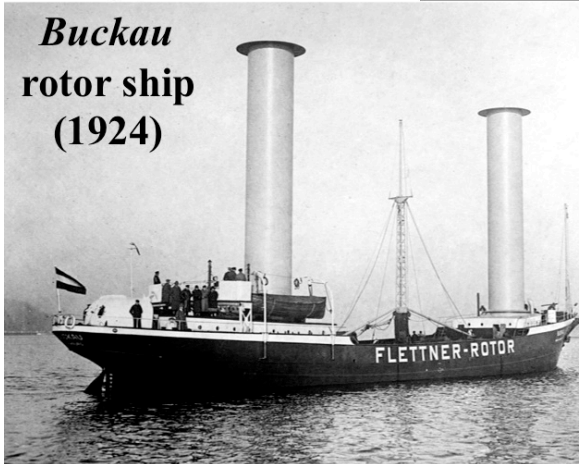
**Anton Flettner  
(1885–1961)**



**Magnus effect:  
a spinning  
cylinder (rotor)  
deflects incoming  
airflow toward  
one side, pushing  
the cylinder toward  
the other side**



***Buckau*  
rotor ship  
(1924)**



***Barbara*  
rotor ship  
(1926)**



**Modern  
rotor ship  
(2018)**



Figure 7.134: Based on the Magnus effect, Anton Flettner developed rotor ships that use spinning cylinders like sails for steering or propulsion. Flettner demonstrated the first rotor ship in 1924; rotors are still used on ships to supplement other methods and increase energy efficiency.

## 7.8 Other Creations in Mechanical Engineering

German-speaking creators also invented many other important devices in the field of mechanical engineering.<sup>12</sup> This section only includes a few illustrative examples:

- 7.8.1. Watches
- 7.8.2. Vacuum pumps and pressure valves
- 7.8.3. Bicycles
- 7.8.4. Polar planimeter
- 7.8.5. Liquid agitators and turbines
- 7.8.6. Gyroscopes and gyrocompasses
- 7.8.7. Sports shoes

### 7.8.1 Watches

Although stationary clocks had been around for centuries, Peter Henlein (German states, 1485–1542) invented the portable watch in 1505. Figure 7.135 shows the first Henlein watch from 1505 (upper right) and a very similar Henlein watch from 1530 (bottom). The science historian Felix Paturi described Henlein's innovations [Paturi 1998, p. 110]:

Bis über die Mitte des 15. Jh. hinaus mussten mechanische Uhren senkrecht stehen, da sie einen Schwerkraftantrieb durch Gewichte besaßen. Die Größe der Gewichte verbot zugleich den Bau kleiner mechanischer Uhren. Erst 1470 wurde der Federaufzug für mechanische Uhren bekannt.

Der Nürnberger Mechaniker Peter Henlein (um 1485–1542) experimentiert als einer der Ersten mit kleinen Uhrfedern. Zugleich erkennt er, dass dieser Antrieb die Uhren lageunabhängig macht, weil die Schwerkraft keine Rolle mehr spielt. Bei seinen Versuchen gelingt es ihm, Uhren klein zu bauen, sodass sie in einförmige Dosen passen, die in der Tasche getragen werden können.

Until beyond the middle of the 15th century, mechanical clocks had to stand vertically, as they had a gravity drive by weights. The size of the weights also prohibited the construction of small mechanical watches. It was not until 1470 that the spring winding mechanism for mechanical watches became known.

The Nuremberg mechanic Peter Henlein (around 1485–1542) was one of the first to experiment with small watch springs. At the same time, he realized that this drive made the watches independent of position, because gravity no longer played a role. In his experiments, he succeeded in making watches so small that they fit into standardized enclosures that could be carried in a pocket.

<sup>12</sup>Buchheim and Sonnemann 1990; Bunch and Hellemans 2004; Cardwell 1995; Challoner 2009; Gööck 2000; Heckl 2010, 2011; Heßler 2012; Jankowsky 2000; König 2000, 2009; König and Schneider 2007; Ludwig 1974; Lundgreen and Grelon 1994; Radkau 1989, 2016; Technisches Museum Wien 2011; Weitensfelder 2009, 2013.



**Peter Henlein (1485–1542) invented the portable watch (1505)**

Figure 7.135: Peter Henlein invented the portable watch in 1505. Upper right: the first Henlein watch from 1505. Bottom: a very similar Henlein watch from 1530.



## 7.8.2 Vacuum Pumps and Pressure Valves

Otto von Guericke (German states, 1602–1686) invented the water barometer, manometer, and air pump. In 1650, he also created the “Magdeburg hemispheres” to demonstrate a vacuum; he pumped the air out of the space formed by two steel hemispheres, then demonstrated that two teams of horses could not pull the spheres apart (Fig. 7.136). *Encyclopedia Britannica* listed some of von Guericke’s accomplishments [EB 2010]:

Guericke was educated at the University of Leipzig and studied law at the University of Jena in 1621 and mathematics and mechanics at the University of Leyden in 1623. In 1631 he became an engineer in the army of Gustavus II Adolphus of Sweden, and from 1646 to 1681 he was *bürgermeister* (mayor) of Magdeburg and magistrate for Brandenburg.

In 1650 Guericke invented the air pump, which he used to create a partial vacuum. His studies revealed that light travels through a vacuum but sound does not. In 1654, in a famous series of experiments that were performed before Emperor Ferdinand III at Regensburg, Guericke placed two copper bowls (Magdeburg hemispheres) together to form a hollow sphere about 35.5 (14 inches) in diameter. After he had removed the air from the sphere, horses were unable to pull the bowls apart, even though they were held together only by the air around them. Thus the tremendous force that air pressure exerts was first demonstrated.

In 1663 he invented the first electric generator, which produced static electricity by applying friction against a revolving ball of sulfur. In 1672 he discovered that the electricity thus produced could cause the surface of the sulfur ball to glow; hence he became the first man to view electroluminescence. Guericke also studied astronomy and predicted that comets would return regularly from outer space.

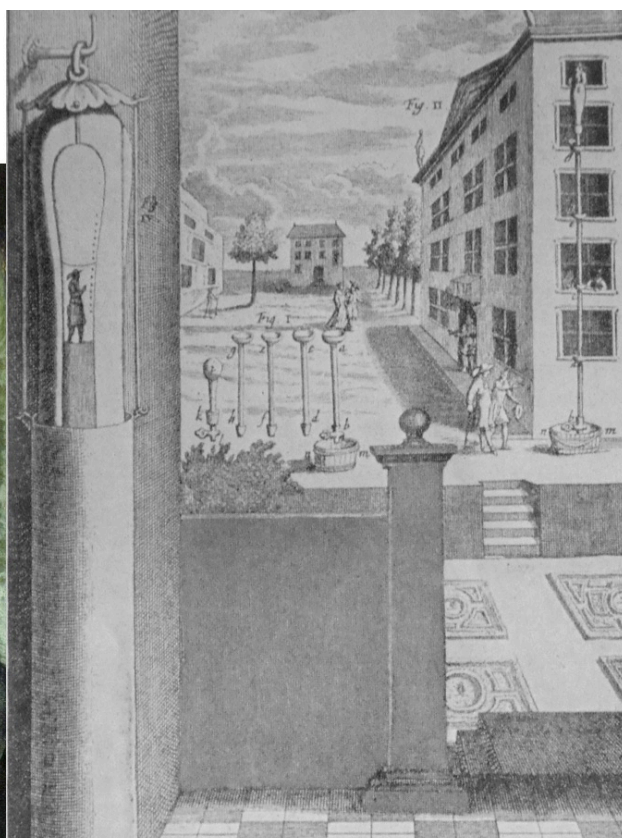
Hermann Sprengel (German states, 1834–1906) invented the first pump for creating a high vacuum ( $<1/100,000,000$  of normal atmospheric pressure), illustrated in Fig. 7.137.

As shown in Fig. 7.138, Hanns Hörbiger (Austrian, 1860–1931) invented the Hörbiger disc valve for high-pressure chemistry, compressors, blast furnaces, and other applications.<sup>13</sup>

---

<sup>13</sup><https://www.fluid.de/faszination-fluid/erfinder-hanns-hoerbiger-und-das-stahlplattenventil-117.html>

**Otto von Guericke (1602–1686)  
invented the water barometer,  
manometer, and air pump**



**Magdeburg  
hemispheres  
to demonstrate  
a vacuum**

Figure 7.136: Otto von Guericke invented the water barometer, manometer, and air pump, and he also created the “Magdeburg hemispheres” to demonstrate a vacuum.

**Hermann Sprengel**  
(1834–1906) invented  
the first pump for  
creating a high vacuum  
( $< 1/100,000,000$  of normal  
atmospheric pressure)

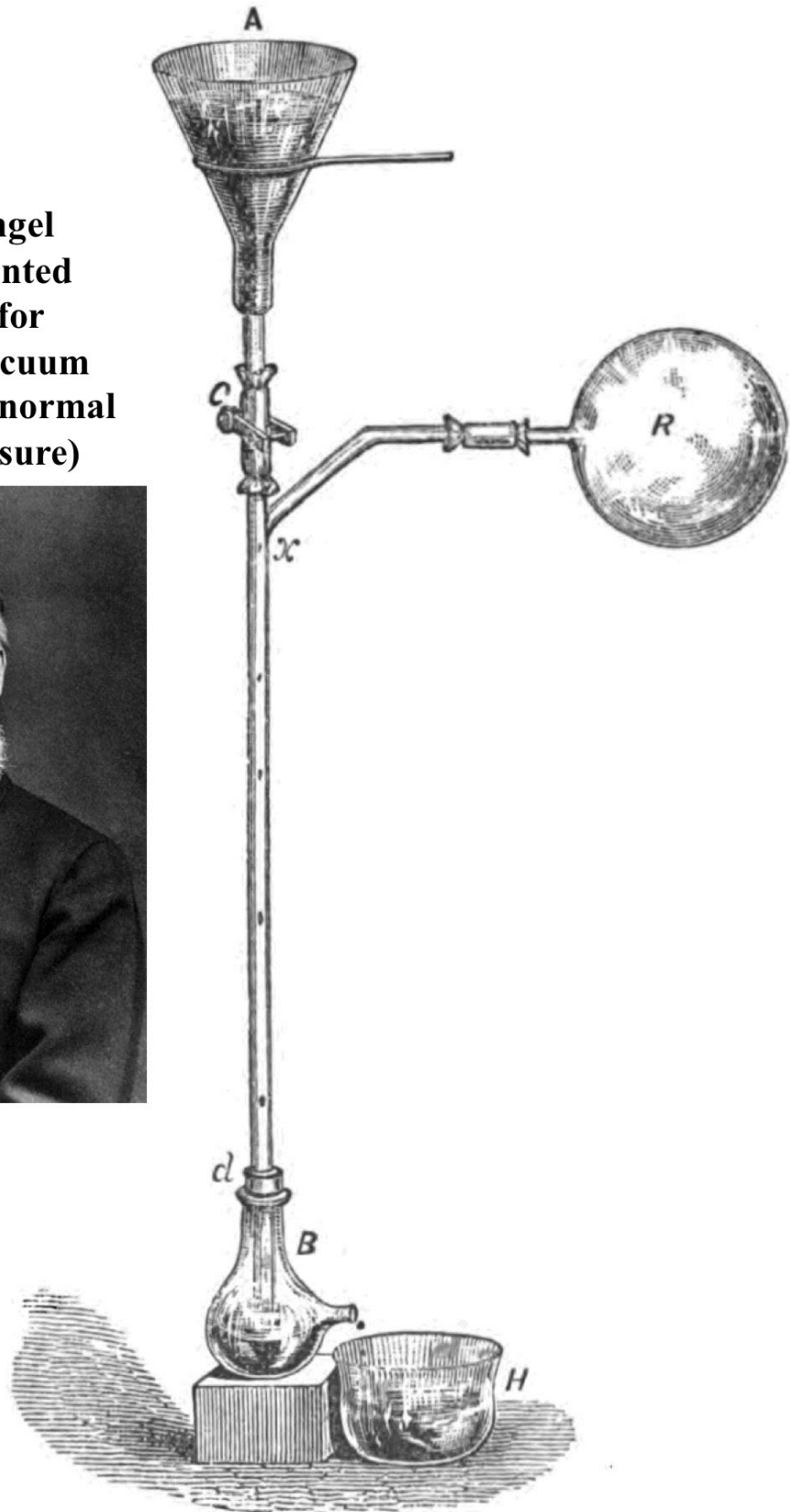
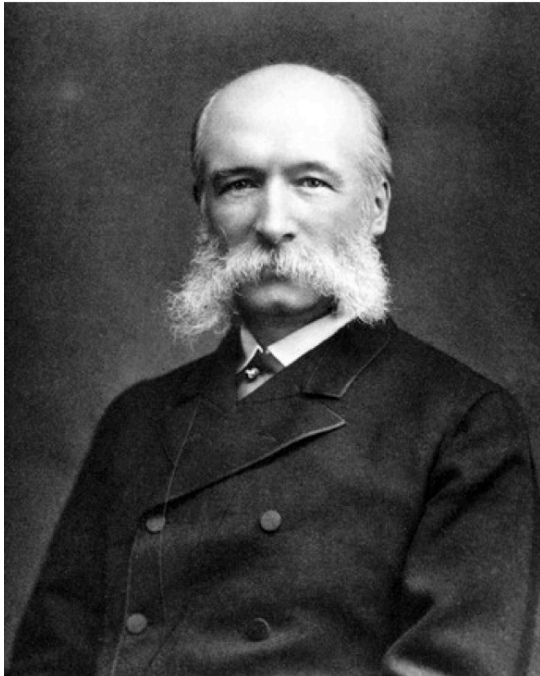
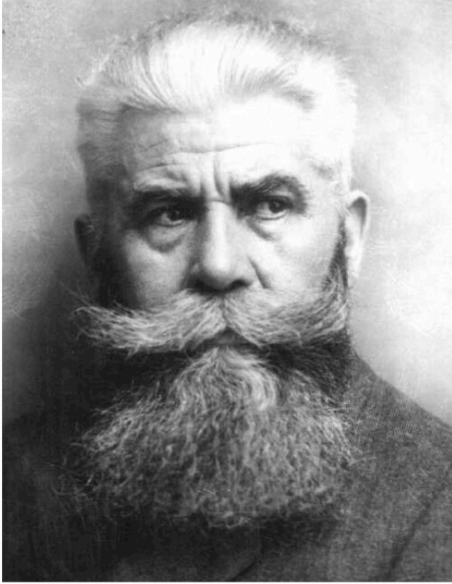


Figure 7.137: Hermann Sprengel invented the first pump for creating a high vacuum.



**Hanns Hörbiger (1860–1931)**

**Hörbiger disc valve for high-pressure chemistry, compressors, etc. (1894)**

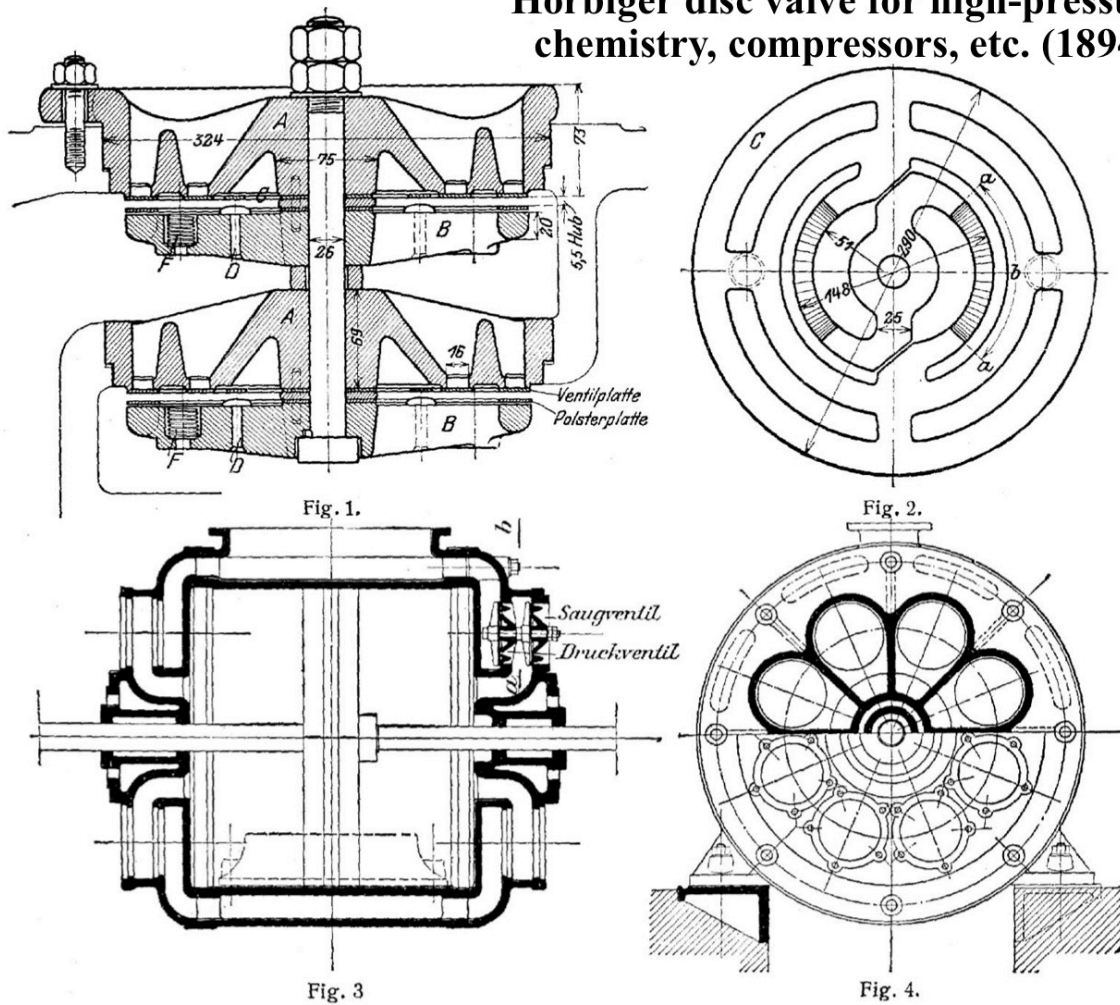


Figure 7.138: Hanns Hörbiger invented the Hörbiger disc valve for high-pressure chemistry, compressors, and other applications.

### 7.8.3 Bicycles

In the 1650s, Hans Hautsch (German states, 1595–1670) and Stephan Farfler or Farffler (German states, 1633–1689) invented and demonstrated tricycles and quadracycles powered by a hand-cranked gearbox for use as wheelchairs by paraplegics. Farfler himself was a paraplegic or amputee who made extensive use of such vehicles (Fig. 7.139).

Karl von Drais (German states, 1785–1851, Fig. 7.140) invented a quadracycle with foot pedals in 1813, and then the first bicycle (without pedals) in 1817. Von Drais also created a paper music recorder in 1812 and the first keyboard typewriter in 1821 (p. 1300).<sup>14</sup> *1001 Inventions That Changed the World* explained the motivation for von Drais's quadracycle and bicycle inventions [Challoner 2009, p. 268]:

[...F]ollowing some bad weather in 1812, the price of oats was climbing, and the German inventor Karl Drais (1785–1851) was looking for something to replace hungry horses. He designed a four-wheeled vehicle, powered by a servant sitting in the back pedaling, while the master steered from the front with a tiller. It did not catch on and Drais decided to focus instead on surveying equipment.

After the 1815 volcanic eruption, even worse weather caused oat prices to climb higher still. The need for horseless transport was even more pressing, and so Drais tried again. He switched from four wheels to two and got rid of the pedals completely. What he invented in 1817 was called the draisine or the *draisienne*, depending on where you lived.

Philipp Moritz Fischer (German, 1812–1890) added pedals back to bicycles in 1853.<sup>15</sup> See Fig. 7.141.

---

<sup>14</sup>Challoner 2009; Ebeling 1985; Lessing 2003, 2010; Michael Rauck 1983.

<sup>15</sup>Feldhaus 1914; Germanisches Nationalmuseum 1985; Max Rauck et al. 1979; von Salvisberg 1980; Wendlandt 1913.



**Hans Hautsch**  
 (not shown,  
 1595–1670) and  
**Stephan Farf(f)ler**  
 (shown, 1633–1689)  
 created tricycles  
 and quadracycles  
 powered by a  
 hand-cranked  
 gearbox for use  
 as wheelchairs by  
 paraplegics (1650s)



**STEPHAN FARFFLER**,  
 Uhrmacher in Altdorff,  
 Auch inventor eines Wagens mit 5. Rädern, darauf  
 er sich, weil er Lahm war, selbston herum gefahren.  
 welcher in der Nürnbergischen Bibliothec  
 gezeigt wird.  
 Starb A. 1689. d. 24. Octobr  
 im 57. sten Jahr Seines Alters

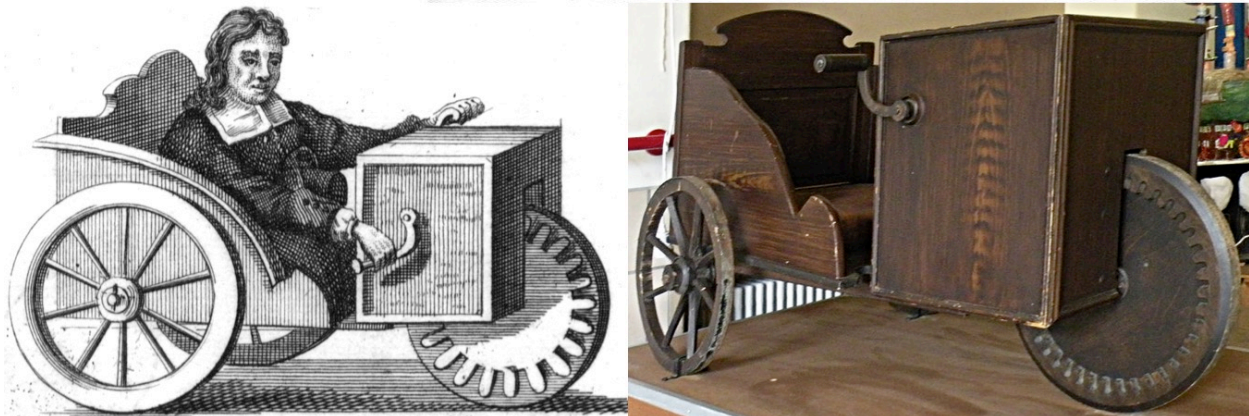


Figure 7.139: In the 1650s, Hans Hautsch and Stephan Farf(f)ler created tricycles and quadracycles powered by a hand-cranked gearbox for use as wheelchairs by paraplegics.





**Karl von Drais  
(1785–1851)**

**Bicycle without pedals  
(1817)**



Figure 7.140: Karl von Drais invented a quadracycle with pedals in 1813, followed in 1817 by the first bicycle without pedals, which proved to be far more popular.





**Philipp Moritz Fischer  
(1812–1890)**

**Bicycle with pedals  
(1853)**

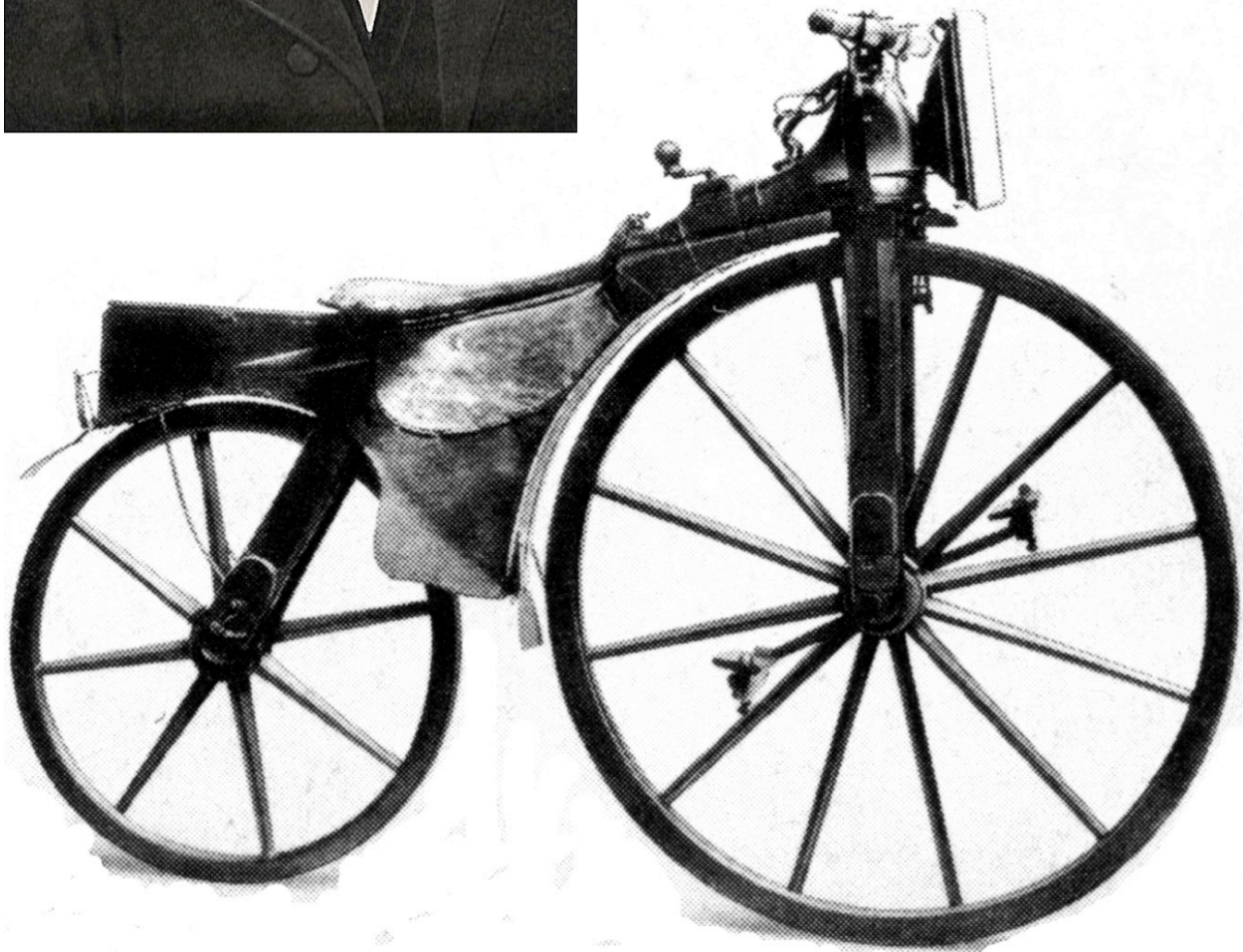


Figure 7.141: Philipp Moritz Fischer (1812–1890) created the first bicycle with pedals in 1853.

#### 7.8.4 Polar Planimeter

In 1854, Jakob Amsler-Laffon (Swiss, 1823–1912) invented the polar planimeter (Fig. 7.142). The *Complete Dictionary of Scientific Biography* explained its importance [<https://www.encyclopedia.com/science/dictionaries-thesauruses-pictures-and-press-releases/amsler-later-amsler-laffon-jakob>]:

Until 1854 Amsler's interests lay in the area of mathematical physics; he published articles on magnetic distribution, the theory of heat conduction, and the theory of attraction. One result of his work was a generalization of Ivory's theorem on the attraction of ellipsoids and of Poisson's extension of that theorem. In 1854 Amsler turned his attention to precision mathematical instruments, and his research resulted in his major contribution to mathematics: the polar planimeter, a device for measuring areas enclosed by plane curves. Previous such instruments, most notably that of Oppikofer (1827), had been based on the Cartesian coordinate system and had combined bulkiness with high cost. Amsler eliminated these drawbacks by basing his planimeter on a polar coordinate system referred to a null circle as curvilinear axis. The instrument, described in "Ueber das Polarplanimeter" (1856), adapted easily to the determination of static and inertial moments and of the coefficients of Fourier series; it proved especially useful to shipbuilders and railroad engineers.

To capitalize on his inspiration, Amsler established his own precision tools workshop in 1854. From 1857 on he devoted full time to the venture. At his death, the shop had produced 50,000 polar planimeters and 700 momentum planimeters.

#### 7.8.5 Liquid Agitators and Turbines

In the 1760s, Gotthard Friedrich Stender (Baltic German, 1714–1796) and Jacob Christian Schäffer (German states, 1718–1790) built clothes washing machines with agitator blades and mechanical drives for multiple machines. See Fig. 7.143.

Viktor Kaplan (Austrian, 1876–1934) invented highly efficient turbines with blades of adjustable tilt for hydroelectric power (pp. 1499, 3757). His designs are still in use today. Oxford University's *Biographical Dictionary of Scientists* described Kaplan's innovation [Porter 1994, p. 378]:

Kaplan published his first paper on turbines in 1908, writing about the Francis turbine and basing it on work that he had done for his doctorate at the Technische Hochschule in Vienna. In connection with this paper, he set up a propeller turbine for the lowest possible fall of water. In 1913 the first prototype of the turbine was completed. The Kaplan turbine was patented in 1920 as a water turbine with adjustable rotor-blades; the runner blades can be varied to match the correct angle for a given flow of water. [...]

The Kaplan turbine in its traditional form has a vertical shaft, although one power-generator design uses a horizontal shaft and an alternator mounted in a 'nacelle' (metal shell) in the water flow. This is particularly suitable for lower-output machines operating on very low heads of water, in which an almost straight water passage is possible.



### 7.8.6 Gyroscopes and Gyrocompasses

Johann Bohnenberger (German, 1765–1831) invented the gyroscope in 1817, as illustrated in Fig. 7.145. By harnessing the basic principles of gyroscopes to create guidance systems, Hermann Anschütz-Kaempfe (German, 1872–1931) and Max Schuler (German, 1882–1972) developed increasingly accurate gyrocompasses from 1904 onward. In 1923, Schuler developed the principle of Schuler tuning that helps to ensure that gyrocompasses remain accurate regardless of where they are carried around the earth. *1001 Inventions That Changed the World* explained the importance of the development of gyrocompasses [Challoner 2009, p. 547]:

Gyrocompasses have two great advantages over magnetic needle compasses: They point to the spin pole of Earth as opposed to the magnetic pole; and they are completely unaffected by the ferrous metal of a ship's hull or the magnetic fields produced by electrical currents running through nearby wires. Their main component is a motorized, fast-spinning, damped, gimballed wheel. When this wheel is not spinning exactly in the plane containing Earth's spin axis, an interaction between the angular momentum of the wheel and the angular momentum of Earth produces a restoring torque that pushes the wheel back into the true north-south orientation.

A ship's gyrocompass is mounted in a complex set of gimbals that isolate the instrument from the ever-present pitching, yawing, and rolling. Aircraft gyrocompasses are even more complicated due to the higher velocity of the plane and the speedy changes in altitude during takeoff and landing.

German scientist Hermann Anschütz-Kaempfe (1872–1931) started working on the device because he needed a compass to guide a submarine on a planned expedition underneath the north polar ice. In partnership with his cousin, Max Schuler, Anschütz-Kaempfe sold a prototype to the German Navy in 1908. Schuler found that if the pendulous suspension of the gyroscope had a period of eighty-four minutes (the period of a pendulum of length equal to Earth's radius), disturbances due to the ship's acceleration were canceled out.

### 7.8.7 Sports Shoes

Adolf Dassler (German, 1900–1978) designed sports shoes (ultimately called Adidas) from 1918 onward. First working with him and then in competition with him, his brother Rudolf Dassler (German, 1898–1974) designed sports shoes (ultimately called Puma) from 1924 onward [Karlsch et al. 2019; Rolf-Herbert Peters 2007]. See Fig. 7.146.

**Jakob Amsler-Laffon (1823–1912)**



**Polar planimeter (1854)**

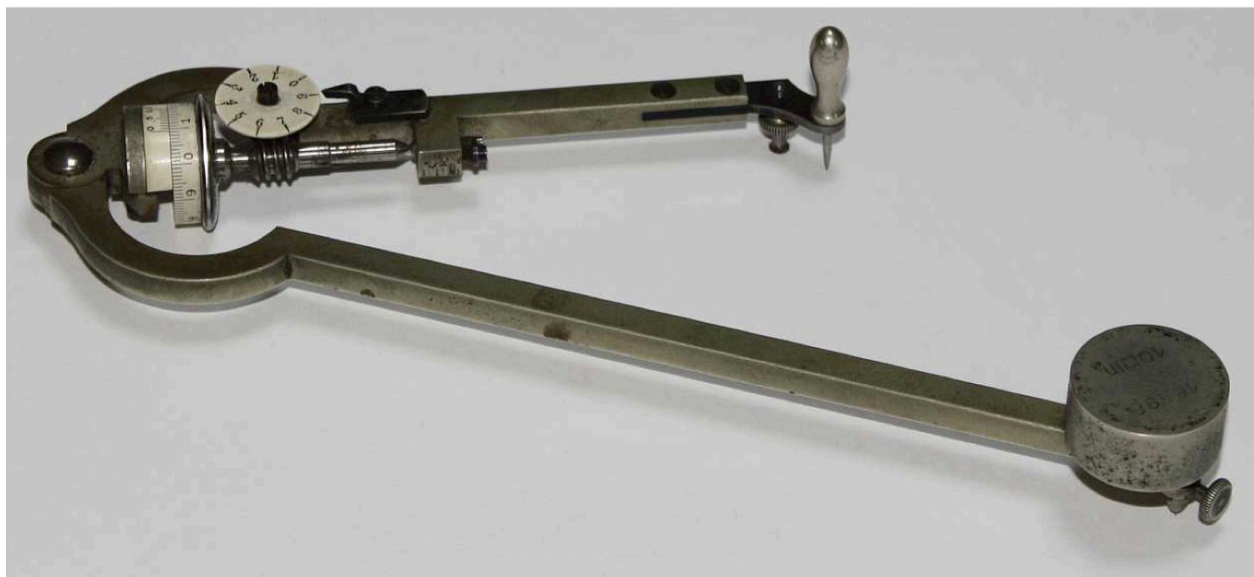


Figure 7.142: Jakob Amsler-Laffon invented the polar planimeter in 1854.



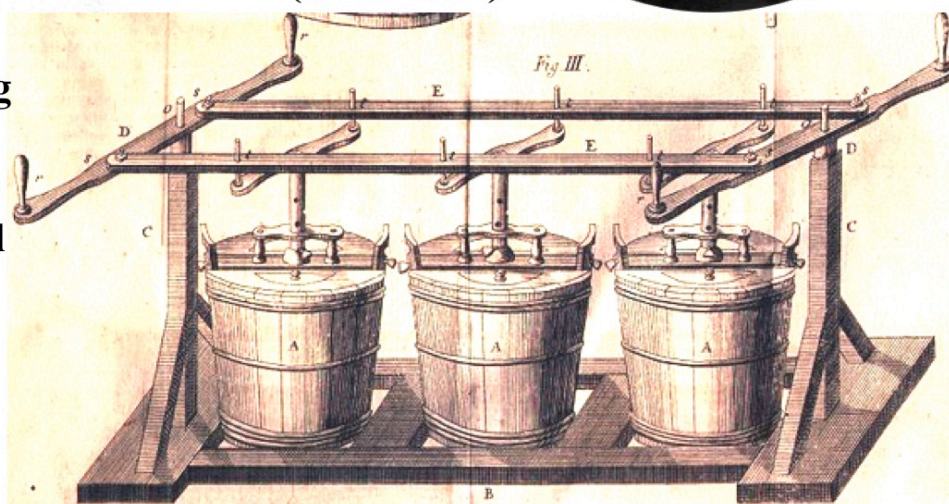


**Gotthard  
Friedrich  
Stender  
(1714–1796)**



**Jacob  
Christian  
Schäffer  
(1718–1790)**

**Clothes washing  
machines with  
agitator blades  
and mechanical  
drives for  
multiple  
machines  
(1760s)**



*Das Maas giebt der Zoberdeckel, welcher 2. Schuh im Durchschnitte hat.*

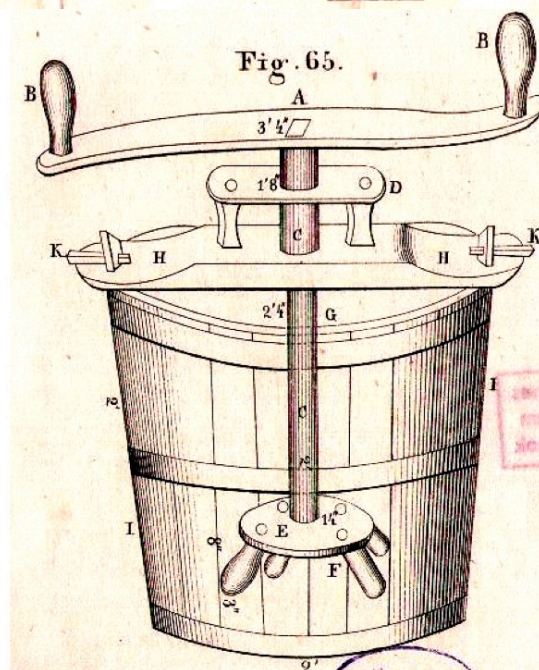


Figure 7.143: In the 1760s, Gotthard Friedrich Stender and Jacob Christian Schäffer built clothes washing machines with agitator blades and mechanical drives for multiple machines.



**Viktor Kaplan  
(1876–1934)**



**Highly efficient turbines  
for hydroelectric power (1912)**



Figure 7.144: Viktor Kaplan invented highly efficient turbines with blades of adjustable tilt for hydroelectric power. See also p. 3757.





**Johann  
Bohnenberger  
(1765–1831)  
invented the  
gyroscope  
(1817)**



**Gyrocompasses (1904 onward)**

**Hermann Anschütz-Kaempfe (1872–1931)    Max Schuler (1882–1972)**



ANSCHÜTZ  
111

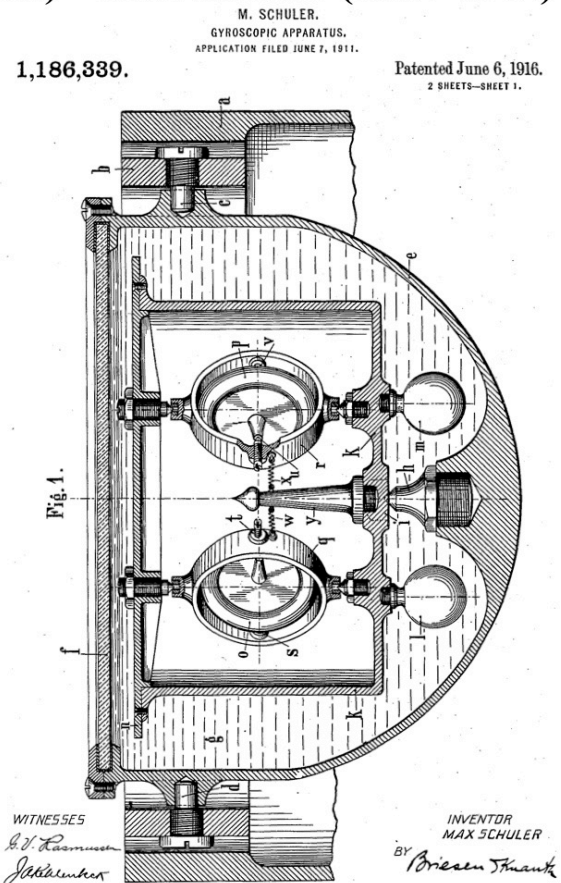


Figure 7.145: Johann Bohnenberger invented the gyroscope in 1817. Hermann Anschütz-Kaempfe and Max Schuler developed increasingly accurate gyrocompasses from 1904 onward.

**Adolf Dassler**  
(1900–1978)

**Sports shoe design 1918–**

**Rudolf Dassler**  
(1898–1974)

**Sports shoe design 1924–**



Figure 7.146: Adolf Dassler designed Adidas sports shoes from 1918 onward, while his brother Rudolf Dassler designed Puma sports shoes from 1924 onward.



